

Whirlpool

SERVICE

CENTRO DE SOLUCIONES



LO ORIGINAL MARCA DIFERENCIA

EXPLOSIONADO DE PARTES
MODELO | ALD1545JE

acros

Whirlpool
CORPORATION

MAYTAG

KitchenAid™

Distribuidor Autorizado

SurteRápido.com

Venta de Refacciones
Electrodomesticas

Lavadora Whirlpool ALD1545JE

Y-1



Y-2

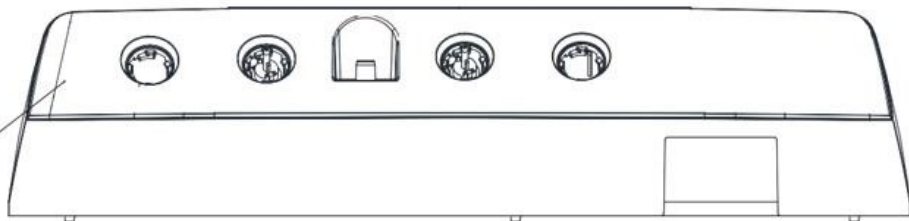

Y-3



Y-4

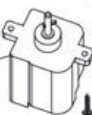

Y-5

Y-6

Y-7

Y-8

Y-9

Y-10

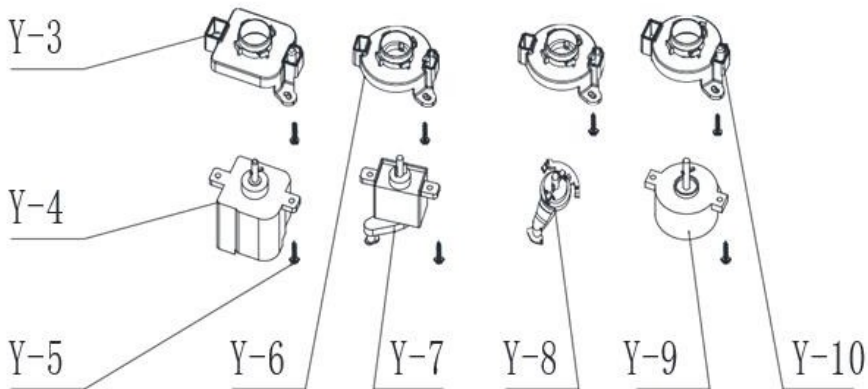

Distribuidor Autorizado

SurteRápido.com

Venta de Refacciones
Electrodomesticas



Lavadora Whirlpool ALD1545JE

No. Ilus.	DESCRIPCIÓN	Cant.	No. de Parte
Y-1	KNOB	4	S00A2Y010XNZ4
Y-2	CONTROL PANEL	1	S6005M12YBK00
Y-3	WASH TIMER	1	S8005Y03YAZ0X
	INSTALLATION PLATE		
Y-4	WASH TIMER	1	A2502Y05XDS14
Y-5	OPTIONAL SWITCH	2	S8005Y03YAZ0P
	INSTALLATION PLATE		
Y-6	OPTIONAL SWITCH	1	A2000Y06XZKB0
Y-7	DRAIN SWITCH	1	D0501Y06XZK00
Y-8	SPIN TIMER	1	S8005Y03YAZ0T
	INSTALLATION PLATE		
Y-9	SPIN TIMER	1	A2315Y07TDS08
Y-10	SCREW ST4.2×13	7	GB845

Distribuidor Autorizado

SurteRápido.com

Venta de Refacciones
Electrodomesticas

Lavadora Whirlpool ALD1545JE

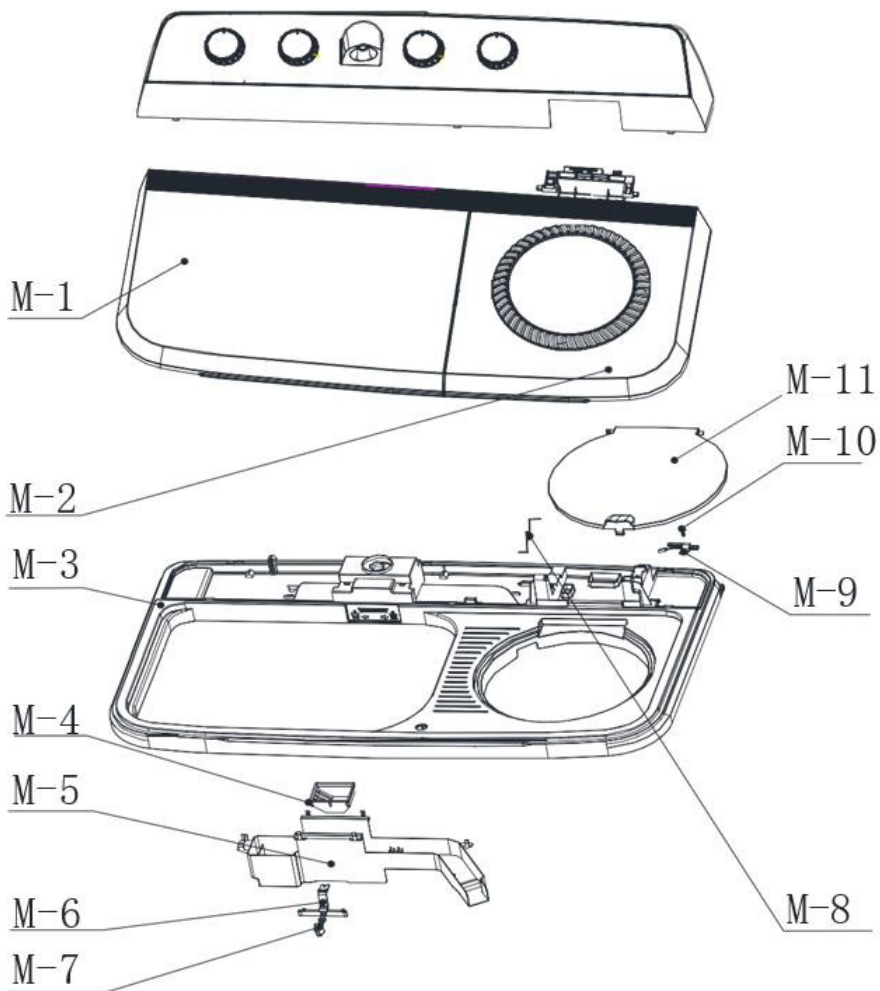

Distribuidor Autorizado

SurteRápido.com

Venta de Refacciones
Electrodomesticas



Lavadora Whirlpool ALD1545JE

No. Ilus.	DESCRIPCIÓN	Cant.	No. de Parte
M-1	WASH COVER	1	S6006M01XGB00
M-2	SPIN COVER	1	S6006M01TGB00
M-3	CONTROL TABLE	1	S6002M06OMK00
M-4	DIVISION UTENSIL	1	S1101M10JSC00
M-5	DIVISION TROUGH	1	A2701M09FSQ00
M-6	DIVISION POLE	1	S1901M08FSG00
M-7	DIVISION PARTICLE	1	A2701M07FSB00
M-8	COVER SPRING	1	A017AM04GTH00
M-9	MICRO SWITCH	1	A0K0ZM03WDK03
M-10	SCREW ST4.2×13	1	GB845
M-11	SPIN MID COVER	1	S1607M02TZG00

Distribuidor Autorizado

SurteRápido.com

Venta de Refacciones
Electrodomesticas

Lavadora Whirlpool ALD1545JE

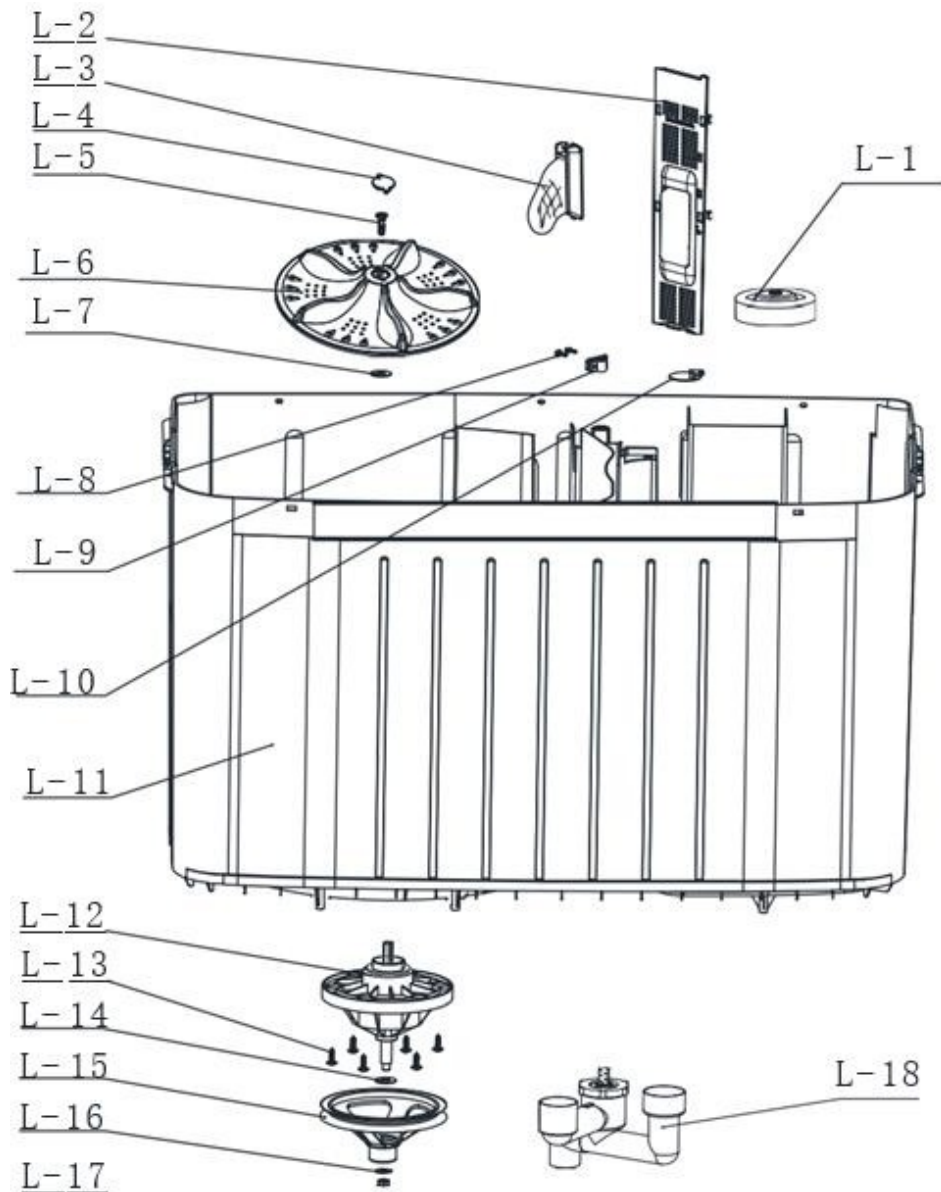

Distribuidor Autorizado

SurteRápido.com

Venta de Refacciones
Electrodomesticas



Lavadora Whirlpool ALD1545JE

No.Ilus.	DESCRIPCIÓN	Cant.	No. de Parte
X-1	SEALING CUP ASSEMBLY	1	A0095X15PWZ01
X-2	OVERFLOW BOARD	1	S1801c010CBSY
X-3	FILTER NET	1	A0801c02GLWSW
X-4	PULSATOR COVER	1	Q9001Z20BLG00
X-5	PULSATOR SCREW	1	A0028X10LDZ00
	ASSEMBLY		
X-6	PULSATOR	1	S7001L030BL00
X-7	PULSATOR GRASKET	1	A0027L04BDP00
X-8	SCREW ST4.2×10	2	GB845
X-9	SMALL BRACKET	1	S1001L08XZJ00
X-10	VALVE PIECES	1	A0028L13DXF00
X-11	WASH AND SPIN TUB	1	S1901L09LTT00
X-12	RETARDER	1	A0000L15JSQ03
X-13	SCREW ST4.8×25	6	GB845
X-14	FLAT GRASKET	1	A0021L17PDD00
X-15	RETARDER BELT PULLEY	1	A0140L18PDL0J
X-16	SPRING GASKET	1	GB93
X-17	NUT M8	1	GB8891M8
X-18	DTAIN VALVE ASSEMBLY	1	S1001L19PSF00

Distribuidor Autorizado

SurteRápido.com

Venta de Refacciones
Electrodomesticas

Lavadora Whirlpool ALD1545JE

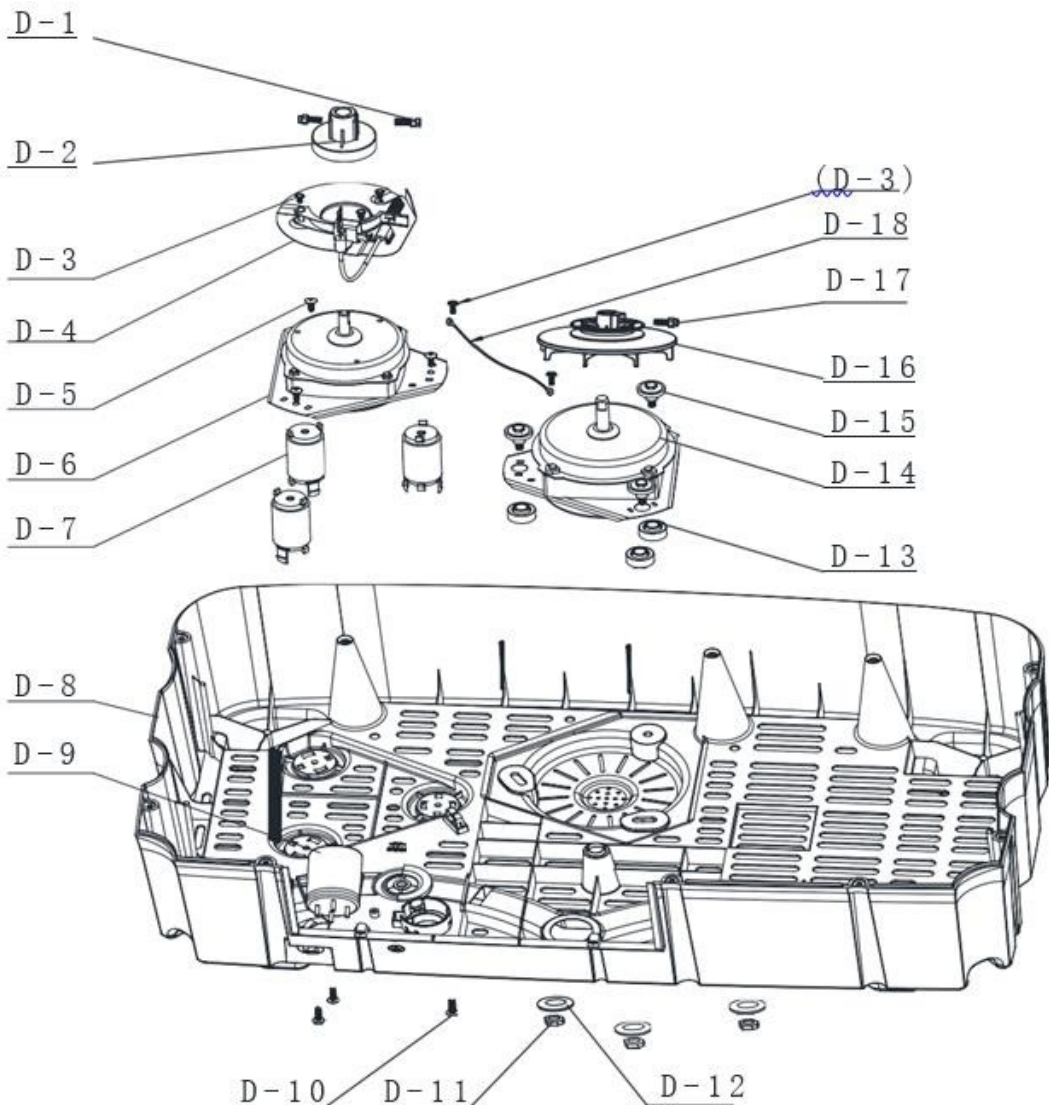

Distribuidor Autorizado

SurteRápido.com

Venta de Refacciones
Electrodomesticas



Lavadora Whirlpool ALD1545JE

No.Ilus.	DESCRIPCIÓN	Cant.	No. de Parte
D-1	SCREW M8×20	1	A20M8D22JLD00
D-2	COUPLING	1	A0000D06LZZ00
D-3	SCREW M4×8	6	GB90744
D-4	BRAKE ASSEMBLY	1	S0901D090ZD00
D-5	SCREW ST4.8×20	3	GB845
D-6	SPIN MOTOR	1	A0080D10TDJ01
D-7	SPRING ASSEMBLY	3	A002KD110TH00
D-8	BASE	1	S1901D050JZ00
D-9	CAPACTIOR	1	A1440D120DR0L
D-10	SCREW ST4.8×25	3	GB845
D-11	NUT M6	3	GB6170M6
D-12	GASKET	3	A0020m04DDQ00
D-13	MOTOR SCREW	3	A0000D02XDZ00
	GASKET(LOWER)		
D-14	WASH MOTOR	1	A0180D03XDJ00
D-15	MOTOR SCREW	3	A00LDD02SDZ00
	GASKET(UPPER)		
D-16	MOTOR PULLEY ASSEMBLY	1	A0057D01PDL04
D-17	SCREW M6×18	1	A20M6D22JLD00
D-18	EARTH WIRE	1	A0300D04JDX0S

Distribuidor Autorizado

SurteRápido.com

Venta de Refacciones
Electrodomesticas

Lavadora Whirlpool ALD1545JE

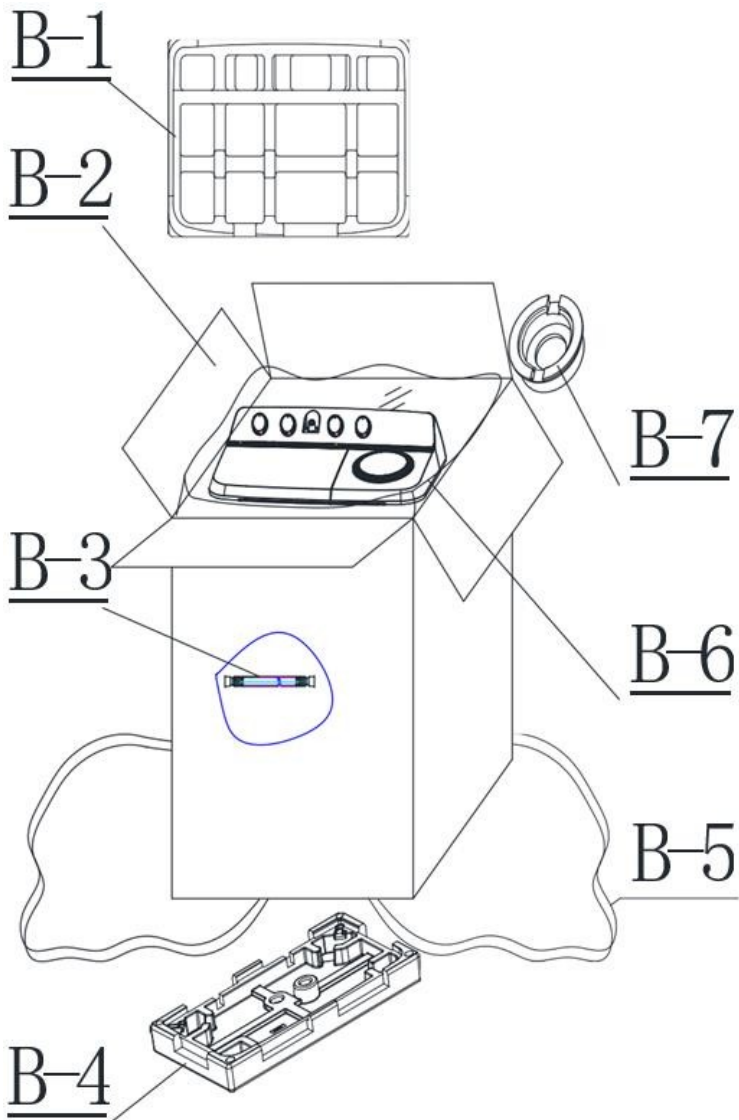

Distribuidor Autorizado

SurteRápido.com

Venta de Refacciones
Electrodomesticas



Lavadora Whirlpool ALD1545JE

No. Ilus.	DESCRIPCIÓN	Cant.	No. de Parte
B-1	TOP LINER	1	S6006B02BSC00
B-2	PACKING BOX	1	S6002B10BZX00
B-3	INLET HOSE	1	A1100Z03JSG00
B-4	BOTTOM LINER	1	S1901B05BXC00
B-5	PACKING LINE	3	A1550B08DBDTJ
B-6	BIG PACKING BAG	1	A0975B07ZJD03
B-7	SETTING CIRCLE	1	A1608B01DWQ00

Distribuidor Autorizado

SurteRápido.com

Venta de Refacciones
Electrodomesticas

Lavadora Whirlpool ALD1545JE

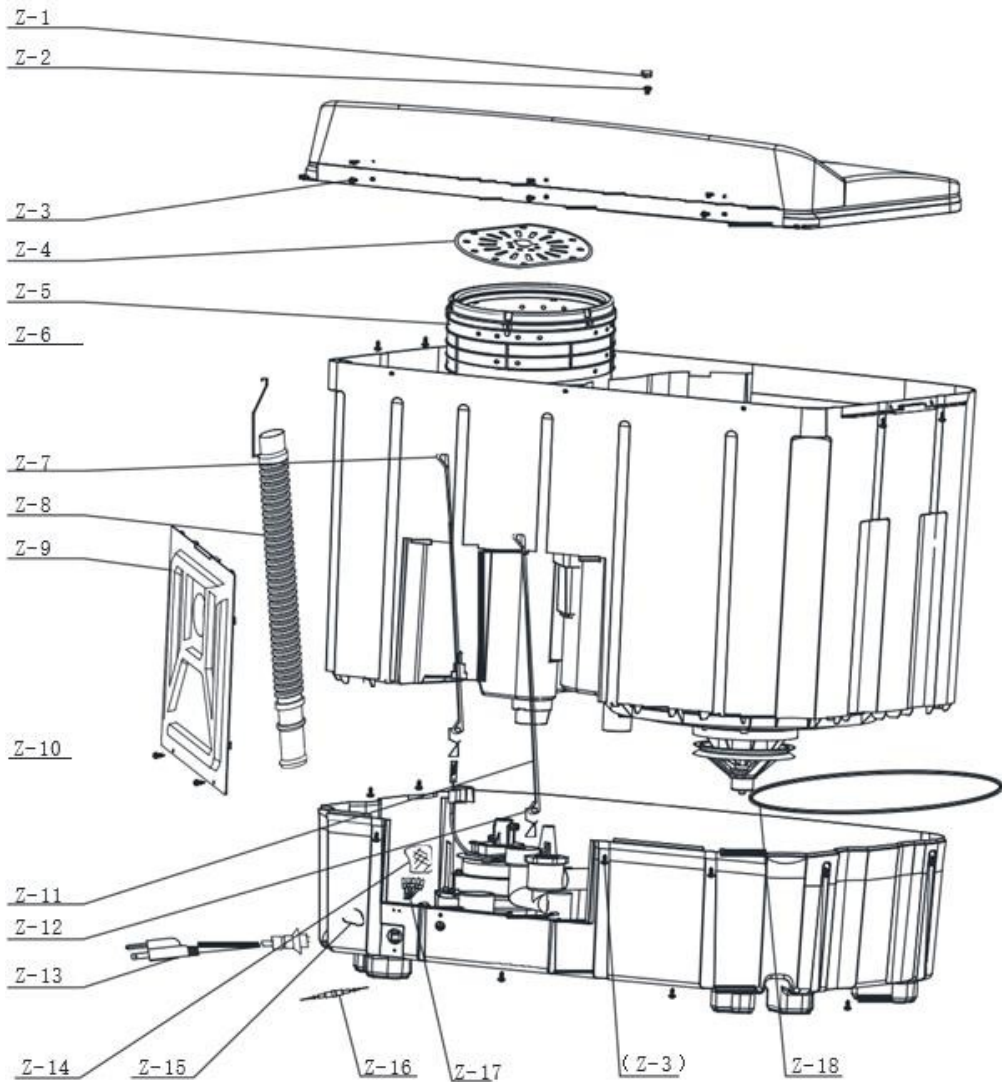

Distribuidor Autorizado

SurteRápido.com

Venta de Refacciones
Electrodomesticas



Lavadora Whirlpool ALD1545JE

No.Ilus.	DESCRIPCIÓN	Cant.	No. de Parte
Z-1	SCREW COVER	2	A0016Z34LDG00
Z-2	SCREW ST4.2×13	2	A4213Z39ZGD00
Z-3	SCREW ST4.2×16	14	GB845
Z-4	SPIN INNER COVER	1	A2012Z05TNG01
Z-5	SPIN TUB ASSEMBLYBLY	1	A2012Z06TST00
Z-6	SCREW ST4.2×13	4	GB845
Z-7	BRAKE DRAGLINE	1	A0500Z09ZLS0T
Z-8			A1180Z11WPG01
Z-9	REAR COVER	1	A2788Z16JHG0S
Z-10	SCREW ST4.2×10	2	GB845
Z-11	DRAIN DRAGLINE	1	A0660Z08PLS00
Z-12	ADJUST ROD	2	A0040Z10TJG01
Z-13	POWER CORD	1	A1700Z15DYX00
Z-14	POLY BAG	1	A0000Z19FCD00
Z-15	WIRE	2	A0220Z400ZX00
Z-16	FUSEGEAR	1	A008AZ14BSXF0
Z-17	SLEEVE	7	A0023Z18JXT00
Z-18	V-BELT	1	A0670Z17VJD00