

# Whirlpool

SERVICE

CENTRO DE SOLUCIONES



LO ORIGINAL MARCA DIFERENCIA

EXPLOSIONADO DE PARTES  
MODELO | ALD1645JE

acros

Whirlpool  
CORPORATION

MAYTAG

KitchenAid

Distribuidor Autorizado

SurteRápido.com

Venta de Refacciones  
Electrodomesticas

Lavadora Whirlpool ALD1645JE

Y-1



Y-2

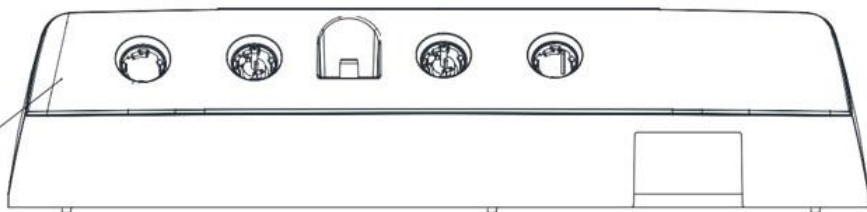

Y-3



Y-4



Y-5

Y-6

Y-7

Y-8

Y-9

Y-10

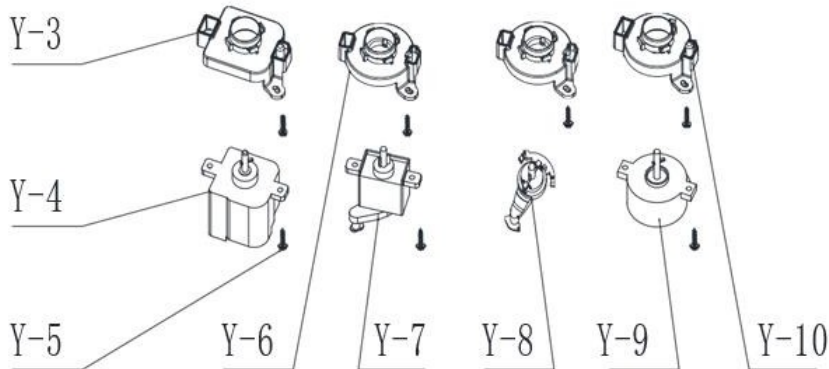

Distribuidor Autorizado

**SurteRápido.com**

Venta de Refacciones  
Electrodomesticas



## Lavadora Whirlpool ALD1645JE

<b><u>No. Ilus.</u></b>	<b><u>DESCRIPCIÓN</u></b>	<b><u>Cant.</u></b>	<b><u>No. de Parte</u></b>
<b>Y-1</b>	KNOB	4	S00A2Y010XNZ4
<b>Y-2</b>	CONTROL PANEL	1	S6005M12YBK00
<b>Y-3</b>	WASH TIMER	1	S8005Y03YAZ0X
	INSTALLATION PLATE		
<b>Y-4</b>	WASH TIMER	1	A2502Y05XDS14
<b>Y-5</b>	OPTIONAL SWITCH	2	S8005Y03YAZ0P
	INSTALLATION PLATE		
<b>Y-6</b>	OPTIONAL SWITCH	1	A2000Y06XZKB0
<b>Y-7</b>	DRAIN SWITCH	1	D0501Y06XZK00
<b>Y-8</b>	SPIN TIMER	1	S8005Y03YAZ0T
	INSTALLATION PLATE		
<b>Y-9</b>	SPIN TIMER	1	A2315Y07TDS08
<b>Y-10</b>	SCREW ST4.2×13	7	GB845

Distribuidor Autorizado

SurteRápido.com

Venta de Refacciones  
Electrodomesticas

# Lavadora Whirlpool ALD1645JE

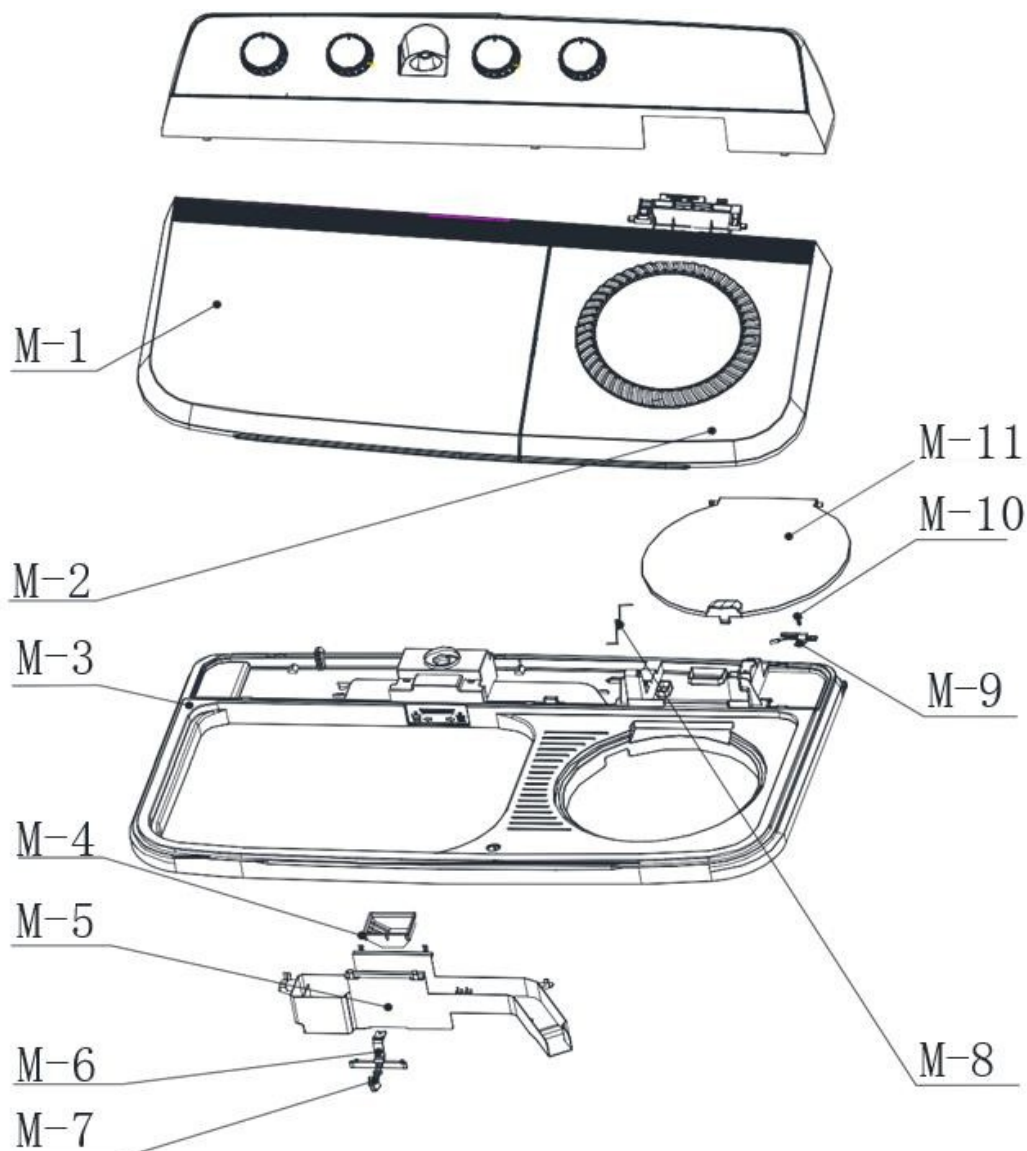

Distribuidor Autorizado

**SurteRápido.com**

Venta de Refacciones  
Electrodomesticas



## Lavadora Whirlpool ALD1645JE

<b><u>No. Ilus.</u></b>	<b><u>DESCRIPCIÓN</u></b>	<b><u>Cant.</u></b>	<b><u>No. de Parte</u></b>
<b>M-1</b>	WASH COVER	1	S6006M01XGB00
<b>M-2</b>	SPIN COVER	1	S6006M01TGB00
<b>M-3</b>	CONTROL TABLE	1	S6002M06OMK00
<b>M-4</b>	DIVISION UTENSIL	1	S1101M10JSC00
<b>M-5</b>	DIVISION TROUGH	1	A2701M09FSQ00
<b>M-6</b>	DIVISION POLE	1	S1901M08FSG00
<b>M-7</b>	DIVISION PARTICLE	1	A2701M07FSB00
<b>M-8</b>	COVER SPRING	1	A017AM04GTH00
<b>M-9</b>	MICRO SWITCH	1	A0K0ZM03WDK03
<b>M-10</b>	SCREW ST4.2×13	1	GB845
<b>M-11</b>	SPIN MID COVER	1	S1607M02TZG00

Distribuidor Autorizado

SurteRápido.com

Venta de Refacciones  
Electrodomesticas

# Lavadora Whirlpool ALD1645JE

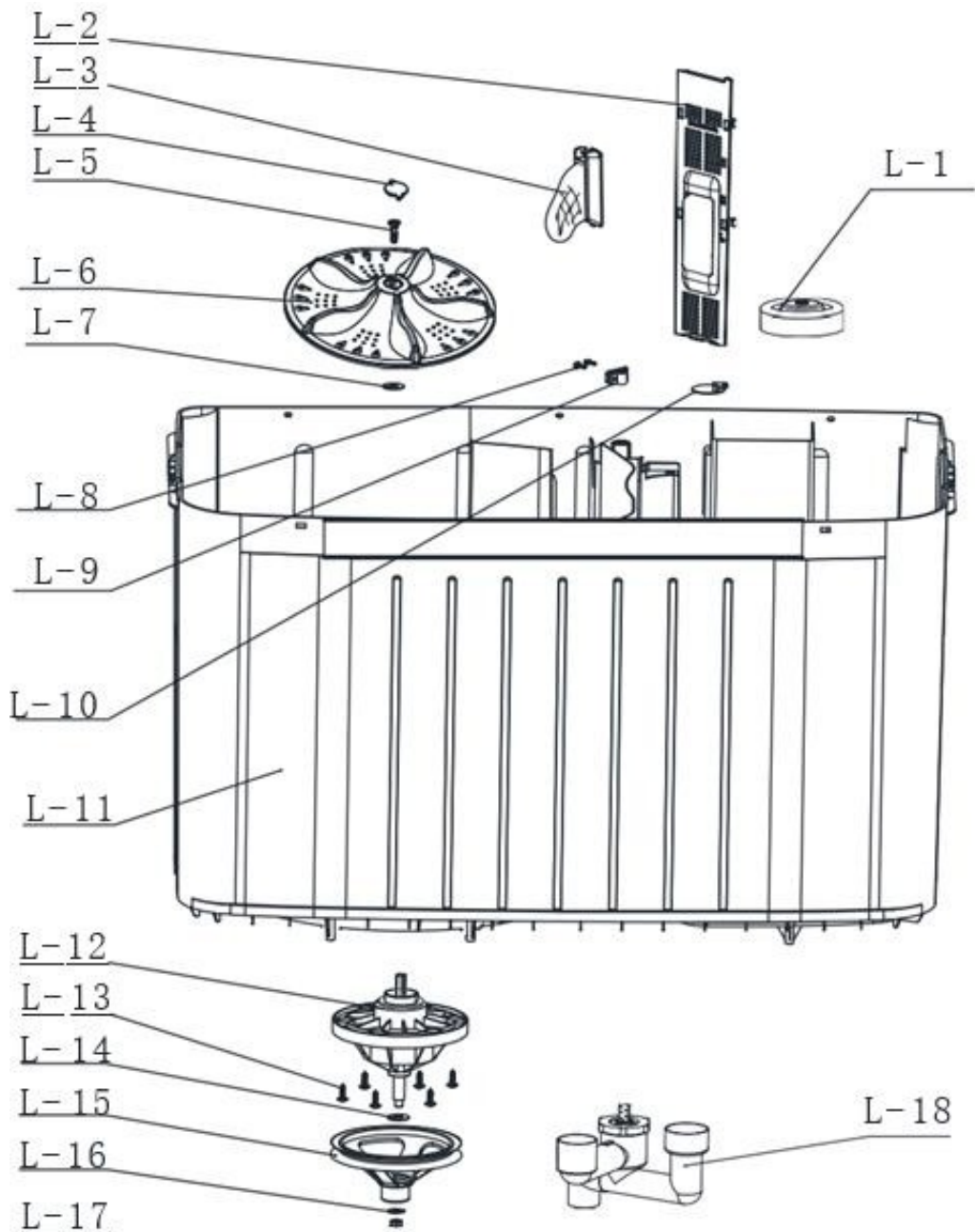

Distribuidor Autorizado

**SurteRápido.com**

Venta de Refacciones  
Electrodomesticas



## Lavadora Whirlpool ALD1645JE

<b>No. Ilus.</b>	<b>DESCRIPCIÓN</b>	<b>Cant.</b>	<b>No. de Parte</b>
X-1	SEALING CUP ASSEMBLY	1	A0095X15PWZ01
X-2	OVERFLOW BOARD	1	S1801c010CBSY
X-3	FILTER NET	1	A0801c02GLWSW
X-4	PULSATOR COVER	1	Q9001Z20BLG00
X-5	PULSATOR SCREW	1	A0028X10LDZ00
	ASSEMBLY		
X-6	PULSATOR	1	S7001L030BL00
X-7	PULSATOR GRASKET	1	A0027L04BDP00
X-8	SCREW ST4.2×10	2	GB845
X-9	SMALL BRACKET	1	S1001L08XZJ00
X-10	VALVE PIECES	1	A0028L13DXF00
X-11	WASH AND SPIN TUB	1	S1901L09LTT00
X-12	RETARDER	1	A0000L15JSQ03
X-13	SCREW ST4.8×25	6	GB845
X-14	FLAT GRASKET	1	A0021L17PDD00
X-15	RETARDER BELT PULLEY	1	A0140L18PDL0J
X-16	SPRING GASKET	1	GB93
X-17	NUT M8	1	GB8891M8
X-18	DTAIN VALVE ASSEMBLY	1	S1001L19PSF00

Distribuidor Autorizado

SurteRápido.com

Venta de Refacciones  
Electrodomesticas

# Lavadora Whirlpool ALD1645JE

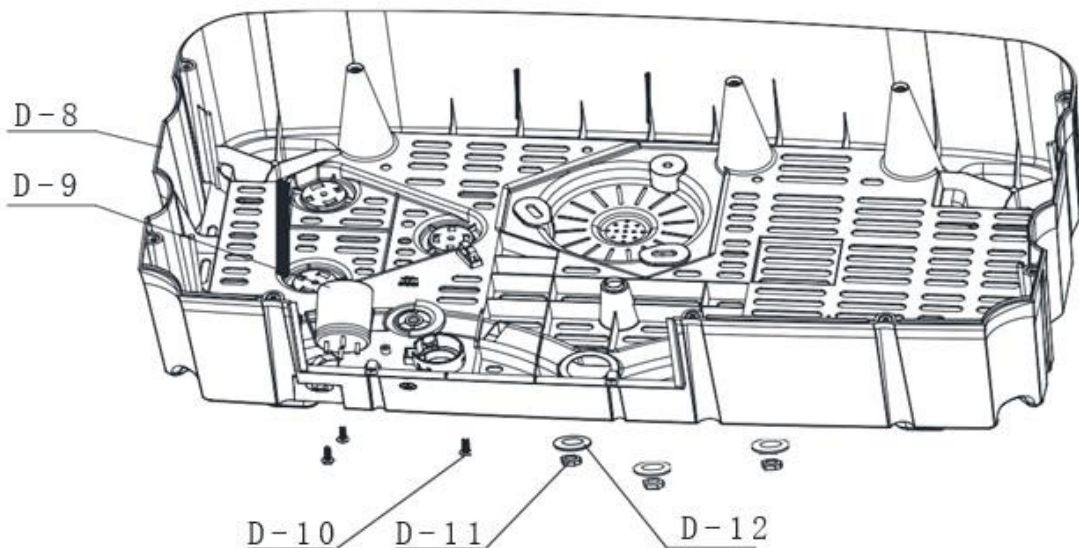
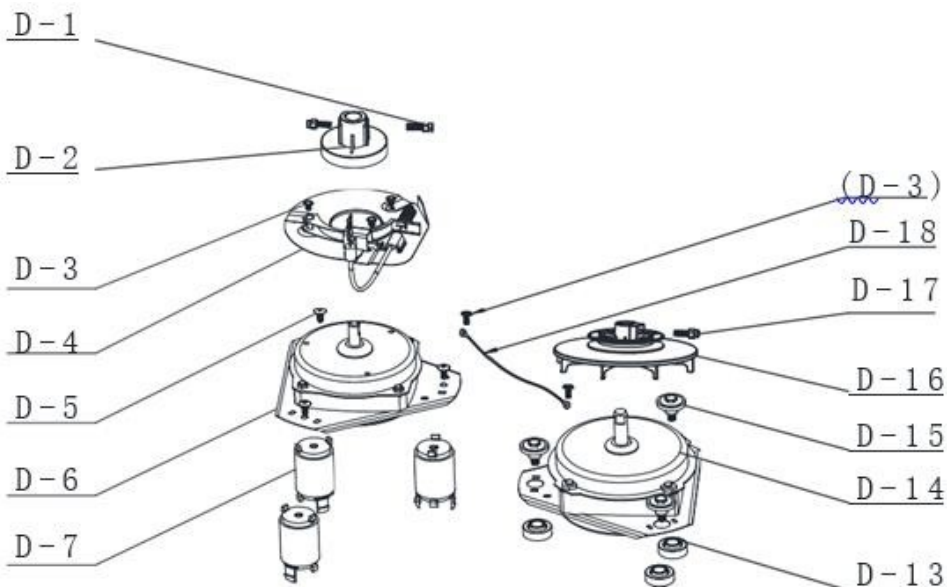



Distribuidor Autorizado

**SurteRápido.com**

Venta de Refacciones  
Electrodomesticas



## Lavadora Whirlpool ALD1645JE

<b>No. Ilus.</b>	<b>DESCRIPCIÓN</b>	<b>Cant.</b>	<b>No. de Parte</b>
<b>D-1</b>	SCREW M8×20	1	A20M8D22JLD00
<b>D-2</b>	COUPLING	1	A0000D06LZZ00
<b>D-3</b>	SCREW M4×8	6	GB90744
<b>D-4</b>	BRAKE ASSEMBLY	1	S0901D090ZD00
<b>D-5</b>	SCREW ST4.8×20	3	GB845
<b>D-6</b>	SPIN MOTOR	1	A0080D10TDJ01
<b>D-7</b>	SPRING ASSEMBLY	3	A002KD110TH00
<b>D-8</b>	BASE	1	S1901D050JZ00
<b>D-9</b>	CAPACTIOR	1	A1440D120DR0L
<b>D-10</b>	SCREW ST4.8×25	3	GB845
<b>D-11</b>	NUT M6	3	GB6170M6
<b>D-12</b>	GASKET	3	A0020m04DDQ00
<b>D-13</b>	MOTOR SCREW	3	A0000D02XDZ00
	GASKET(LOWER)		
<b>D-14</b>	WASH MOTOR	1	A0180D03XDJ00
<b>D-15</b>	MOTOR SCREW	3	A00LDD02SDZ00
	GASKET(UPPER)		
<b>D-16</b>	MOTOR PULLEY ASSEMBLY	1	A0057D01PDL04
<b>D-17</b>	SCREW M6×18	1	A20M6D22JLD00
<b>D-18</b>	EARTH WIRE	1	A0300D04JDX0S

Distribuidor Autorizado

SurteRápido.com

Venta de Refacciones  
Electrodomesticas

Lavadora Whirlpool ALD1645JE

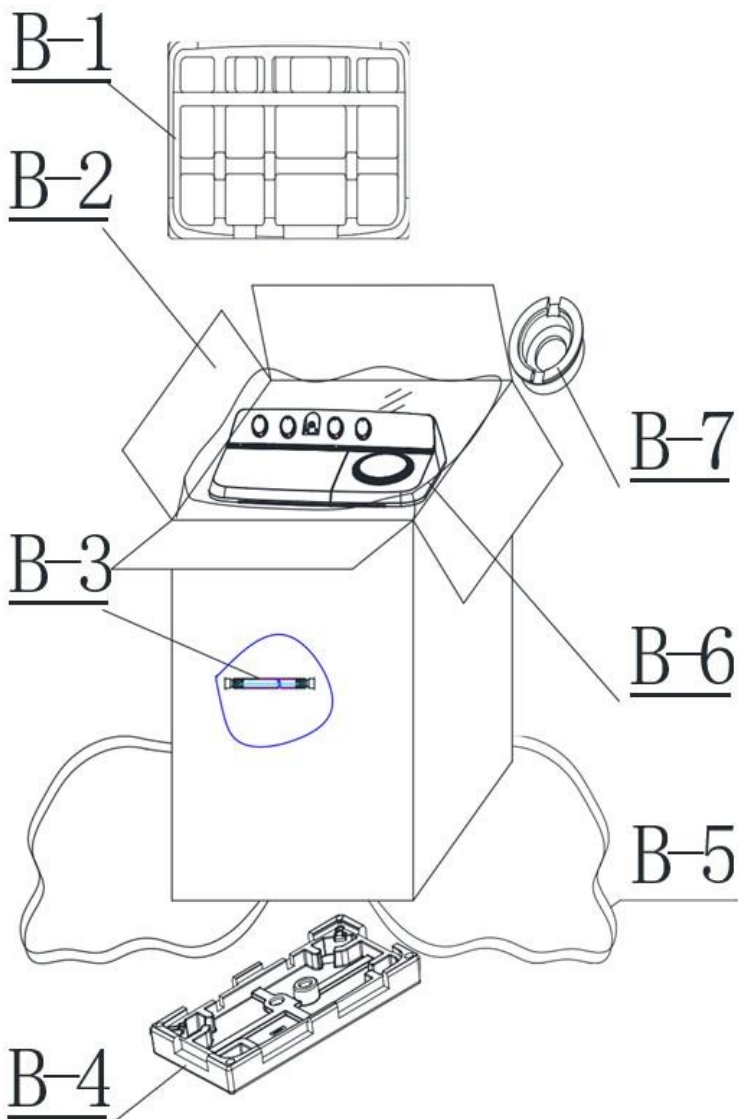

Distribuidor Autorizado

**SurteRápido.com**

Venta de Refacciones  
Electrodomesticas



## Lavadora Whirlpool ALD1645JE

<b><u>No. Ilus.</u></b>	<b><u>DESCRIPCIÓN</u></b>	<b><u>Cant.</u></b>	<b><u>No. de Parte</u></b>
<b>B-1</b>	TOP LINER	1	S6006B02BSC00
<b>B-2</b>	PACKING BOX	1	S6002B10BZX00
<b>B-3</b>	INLET HOSE	1	A1100Z03JSG00
<b>B-4</b>	BOTTOM LINER	1	S1901B05BXC00
<b>B-5</b>	PACKING LINE	3	A1550B08DBDTJ
<b>B-6</b>	BIG PACKING BAG	1	A0975B07ZJD03
<b>B-7</b>	SETTING CIRCLE	1	A1608B01DWQ00

Distribuidor Autorizado

SurteRápido.com

Venta de Refacciones  
Electrodomesticas

# Lavadora Whirlpool ALD1645JE

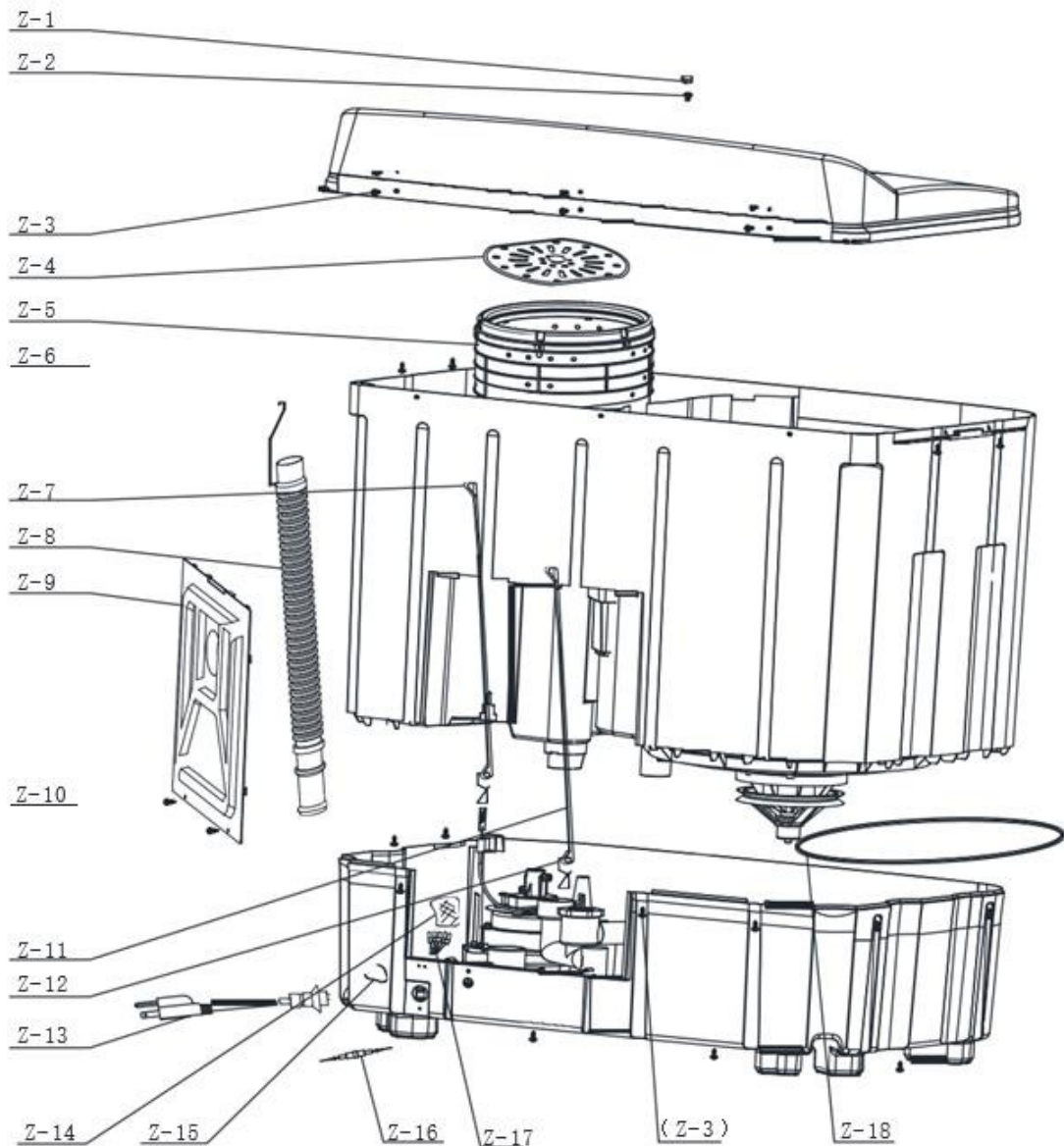

Distribuidor Autorizado

**SurteRápido.com**

Venta de Refacciones  
Electrodomesticas



## Lavadora Whirlpool ALD1645JE

<b><u>No. Ilus.</u></b>	<b><u>DESCRIPCIÓN</u></b>	<b><u>Cant.</u></b>	<b><u>No. de Parte</u></b>
<b>Z-1</b>	SCREW COVER	2	A0016Z34LDG00
<b>Z-2</b>	SCREW ST4.2×13	2	A4213Z39ZGD00
<b>Z-3</b>	SCREW ST4.2×16	14	GB845
<b>Z-4</b>	SPIN INNER COVER	1	A2012Z05TNG01
<b>Z-5</b>	SPIN TUB ASSEMBLYBLY	1	A2012Z06TST00
<b>Z-6</b>	SCREW ST4.2×13	4	GB845
<b>Z-7</b>	BRAKE DRAGLINE	1	A0500Z09ZLS0T
<b>Z-8</b>			A1180Z11WPG01
<b>Z-9</b>	REAR COVER	1	A2788Z16JHG0S
<b>Z-10</b>	SCREW ST4.2×10	2	GB845
<b>Z-11</b>	DRAIN DRAGLINE	1	A0660Z08PLS00
<b>Z-12</b>	ADJUST ROD	2	A0040Z10TJG01
<b>Z-13</b>	POWER CORD	1	A1700Z15DYX00
<b>Z-14</b>	POLY BAG	1	A0000Z19FCD00
<b>Z-15</b>	WIRE	2	A0220Z400ZX00
<b>Z-16</b>	FUSEGEAR	1	A008AZ14BSXF0
<b>Z-17</b>	SLEEVE	7	A0023Z18JXT00
<b>Z-18</b>	V-BELT	1	A0670Z17VJD00