



EXPLOSIONADO DE PARTES — LAVADORA UNA TINA —





LAVADORA ALF1651EB1

Marca	Acros
Capacidad	15 Kgs.
Color	Gris

Tina / Faldon

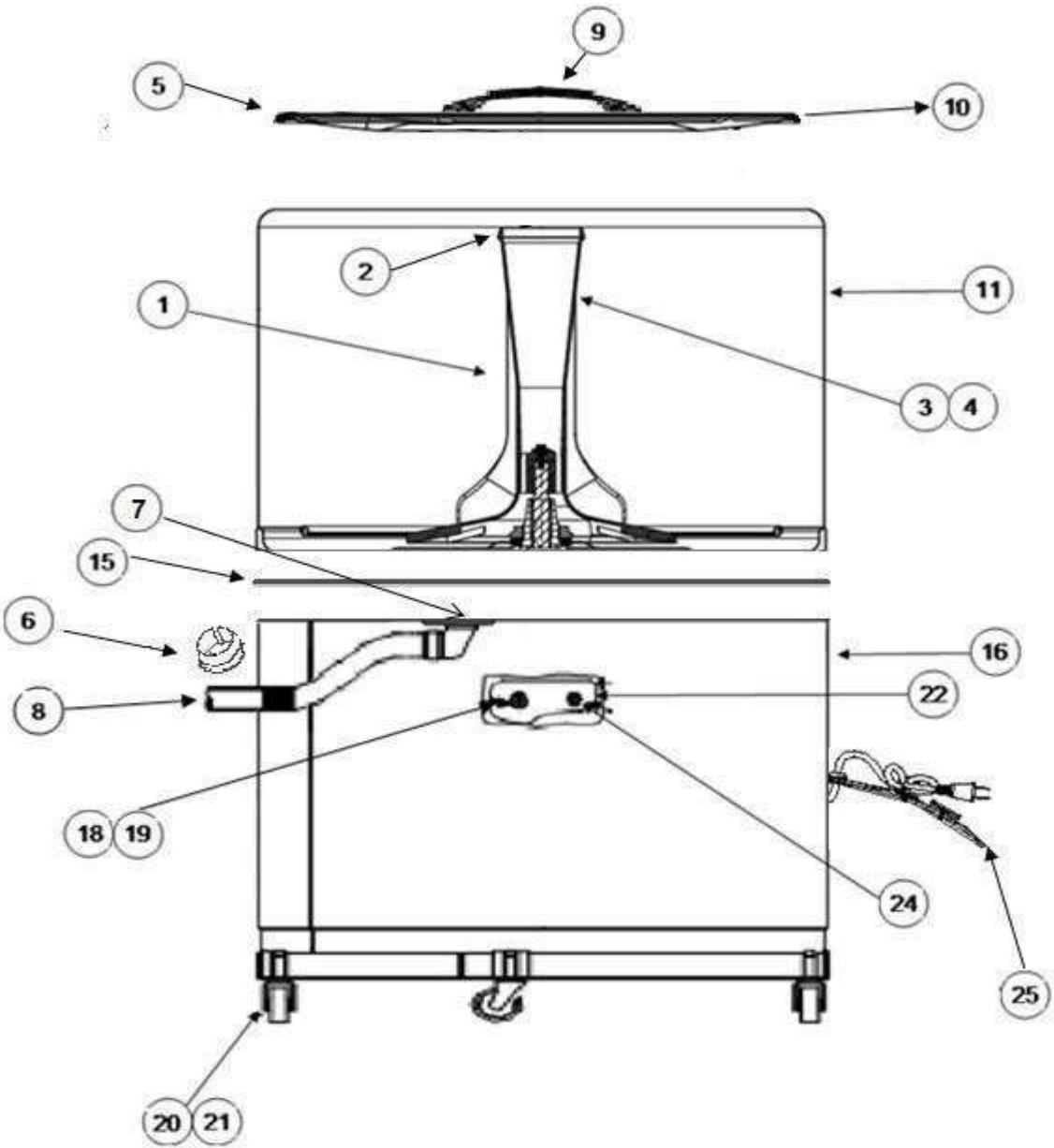

Marca		Acros	
Capacidad		15 Kg.	
Color		Gris	
Tina / Faldon			
R e f	Descripción	C a n t	Numero de Parte
1	CONJUNTO CUERPO AGITADOR	1	8567980
2	TAPON AGITADOR	1	8567935
3	TORNILLO AGITADOR	1	3400058
4	TACO BASE MACHO	1	8317473
5	EMPAQUE TAPA VOLCAN	1	W10859130
6	CASQUILLO MANGUERA	1	92311114
7	PROTECTOR TINA	1	W10859126
8	CONJUNTO MANG.DE DESAGUE	1	W11384194
9	JALADERA TAPA VOLCAN	1	W10854791
10	CONJUNTO TAPA TINA	1	W10873553
11	CONJUNTO TINAS	1	W10296533
✓	HOLDER SUJETADOR CONJ MANG.	1	W11384195
12	TUERCA POSTE	1	92311108
15	SELLO FALDON TINA	1	W10859128
16	CONJUNTO FALDON	1	W10306783
18	TARJETA CONTROL	1	***
19	PERILLA TIMER 15 MIN	1	W10855373
20	CONJUNTO CASQUILLO RODAJA 2.5"	4	8567759
21	C-RING FOR CASTER/VOLCAN	4	8567729
22	PANEL DE CONTROL (OVERLAY)	1	W10858174
24	PERILLA SWITCH	**	***
25	CABLE TOMACORRIENTE	1	W10196958

Marca	Acros
Capacidad	15 Kgs.
Color	Gris
Sistema Interno	

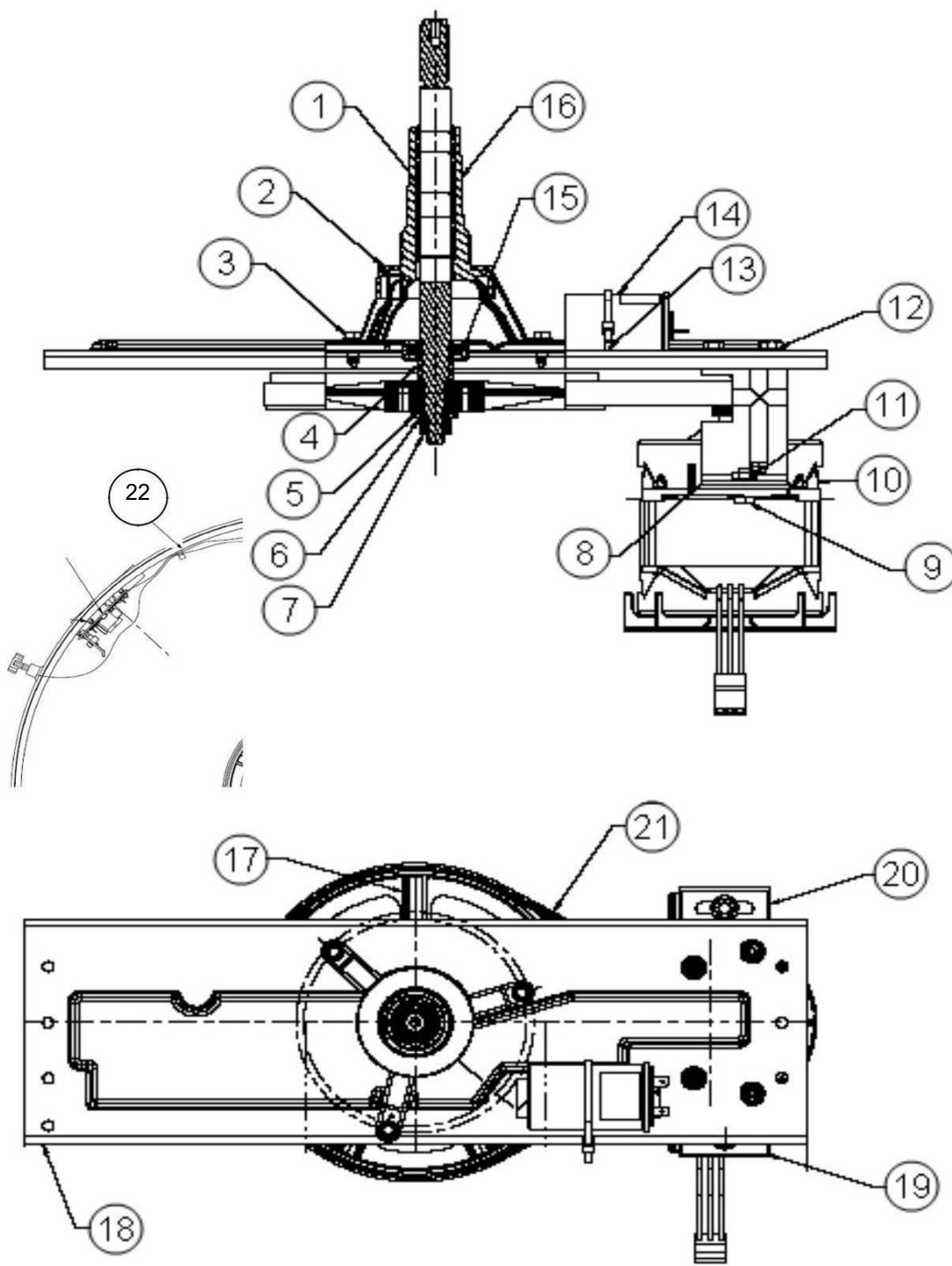

Marca		Acros	
Capacidad		15 Kgs.	
Color		Gris	
Sistema Interno			
R e f	Descripción	C a n t	Numero de Parte
1	ENSAMBLE FLECHA AGITADOR	1	W10413525
2	ARANDELA PLANA HULE 1 7/8	1	8057844
3	PIJA21 H 1/4 14X 3/4	3	8317812
4	BUJE BALERO	1	8317473
5	ARANDELA PLANA	1	8057844
6	ARANDELA DE PRESION	1	8057819
7	TUERCA HEX 7/16	1	8057808
8	ESPACIADOR SOP MOTOR VOLCAN	2	8057828
9	TORNILLO 5/16 18X3	2	8057843
10	MOTOR ASM / PULLEY	1	W10731739
11	TUERCA HEX 5/16	**	***
12	TORNILLO 1/4	**	***
13	WIRE TIE	1	W10727085
14	CAPACITOR	1	W10190199
15	BALERO RADIAL	1	W10712405
16	AGITADOR POST ASSY	1	W10307187
17	AGITADOR PULLEY W / INSERT	1	W10178961
18	BASE TRANSMISION VOLCAN	1	8057747
19	SOPORTE MOTOR IZQ VOLCAN	1	8057749
20	SOPORTE MOTOR DER VOLCAN	1	8057750
21	BELT 320 JT	1	W11130864
22	ARNES ENSAMBLE	1	W10755149
	ENSAMBLE DE TRANSMISIÓN	1	W10207417