

CONTROL PANEL

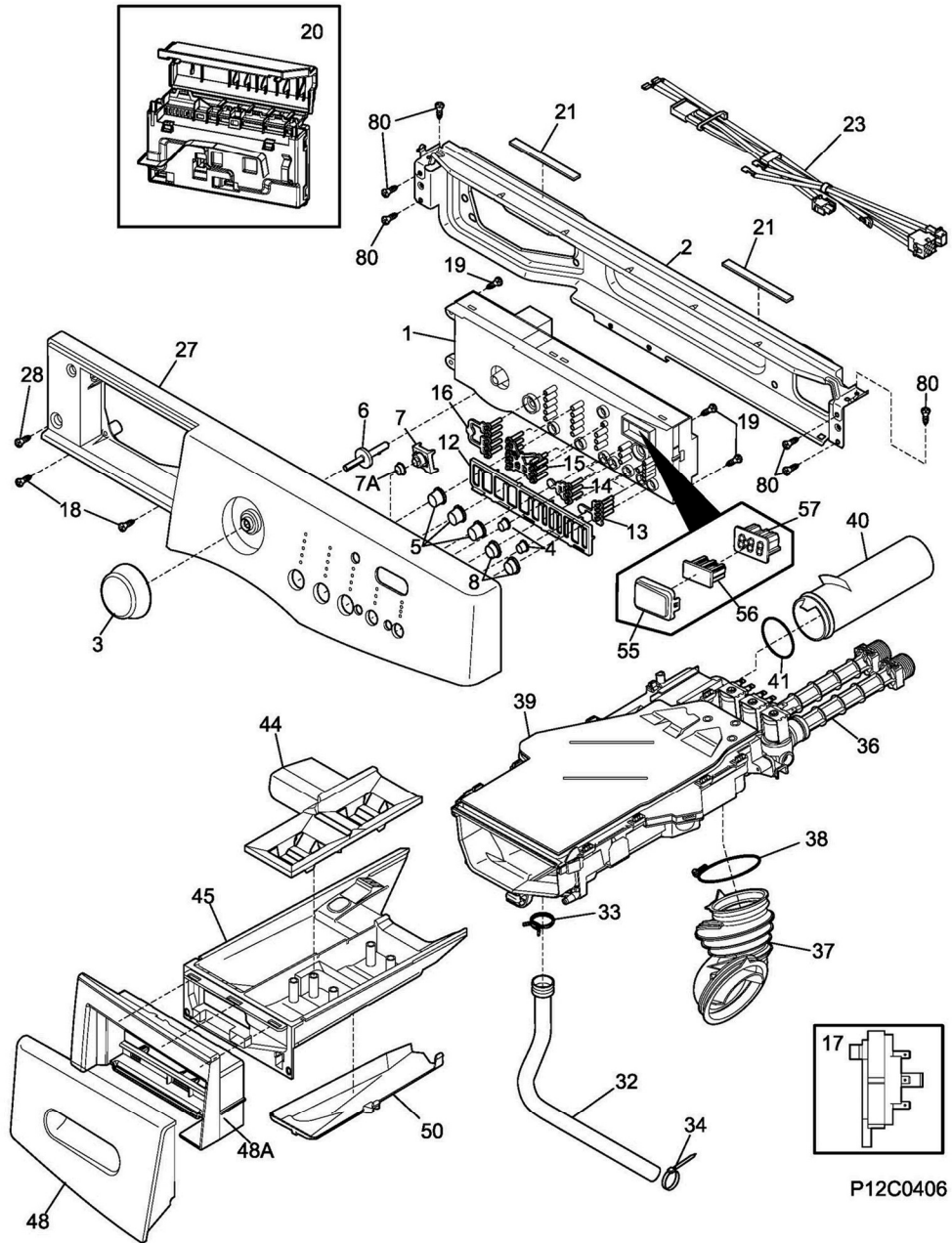

Guía	Descripción	Número
1	CONTROL BOARD	809055505
2	BRACKET	134887400
3	KNOB	137314627
4	PUSH BUTTON	137320825
5	PUSH BUTTON	137314725
6	Pin,program knob	134347700
7	PUSH BUTTON	134885100
7A	CAP	137360300
8	PUSH BUTTON	137314825
12	SPRING	137320500
13	Light Pipe - Start Group	134557500
14	Light Pipe - Row of 3	134557400
15	Light Pipe,5 x 4	134552800
16	Light Pipe - Row of 5	134600000
17	Water Level Pressure Switch	134762010
19	Door Catch Screw	131302901
20	CONTROL BOARD	137208014NH
21	Dampener,vibration	134407900
23	HARNESS	137288500
27	PANEL	137313910
28	Screw - Sold Individually	131205300
32	HOSE	134586500
33	Hose Clamp	134737300
34	WIRE TIE	5304464772
36	Water Inlet Valve	134959340
37	Dispenser to Tub Hose	134372300
38	Dispenser Hose Clamp	134372400
39	HOUSING	134446140
40	Tube,disp-to-overflow	134372100
41	O-ring,overflow tube	134372200
44	Dispenser Drawer Cover - Bisque	134370200
45	Dispenser Drawer	134370000
48	HANDLE, DRAWER	137314310
48A	Dispenser Drawer Handle Frame - Whit	137314510
50	Dispenser Drawer Conveyor	134370100
55	Display Window	137320700
56	Digital Display Light Pipe	134557300
57	Display,digital	134503300

CABINET/TOP

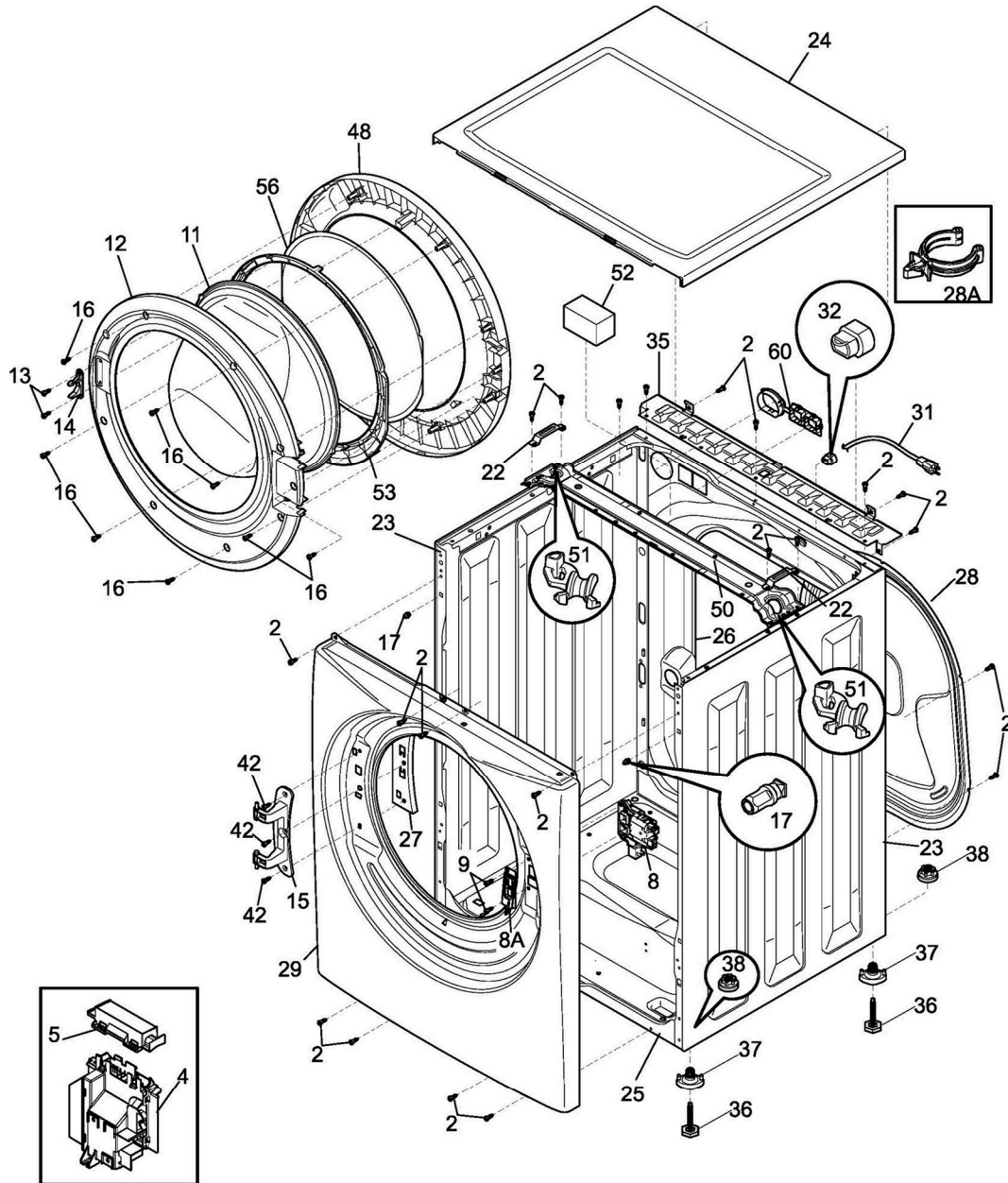

P12V0162

Guía	Descripción	Número
2	SCREW	131168200
4	Motor Control Board	134618213
5	COVER	134649700
8	Front Load Washer Door Lock and Switch Assemb	131763256
8A	Door Vent	137279900
9	Screw	131302800
11	Door Glass	134366400
12	Interior Door Frame - Gray	137280302
13	Door Catch Screw	131302901
14	Door Striker	131763302
15	Door Hinge with Bushings	134550800
16	Screw - Sold Individually	131205300
17	CLIP	134638700
22	BRACKET-SPRING	134648500
23	PANEL	134958010
24	PANEL	134638510
25	BASE	134646001
26	PANEL	134962000
27	Hinge Bracket	134550900
28	PANEL	134646200
28A	CLIP	134876501
29	PANEL	137021811
31	POWER CORD	137011400
32	BUSHING	5303209428
35	BRACKET	134713100
36	Leveling Leg	134639100
37	BUSHING	134617600
38	NUT	134639200
48	Exterior Door Panel - Chrome	5304506743
50	BRACKET	134645600
51	PROTECTOR	134655800
52	Dampener,vibration ,foam	131931202
53	Washer Door Transition Ring	137266700
56	GLASS	137578120
60	Grommet,dispenser ,back panel	134372000

Publication No: 5995636916

FFFWS5100PW0

MOTOR/TUB

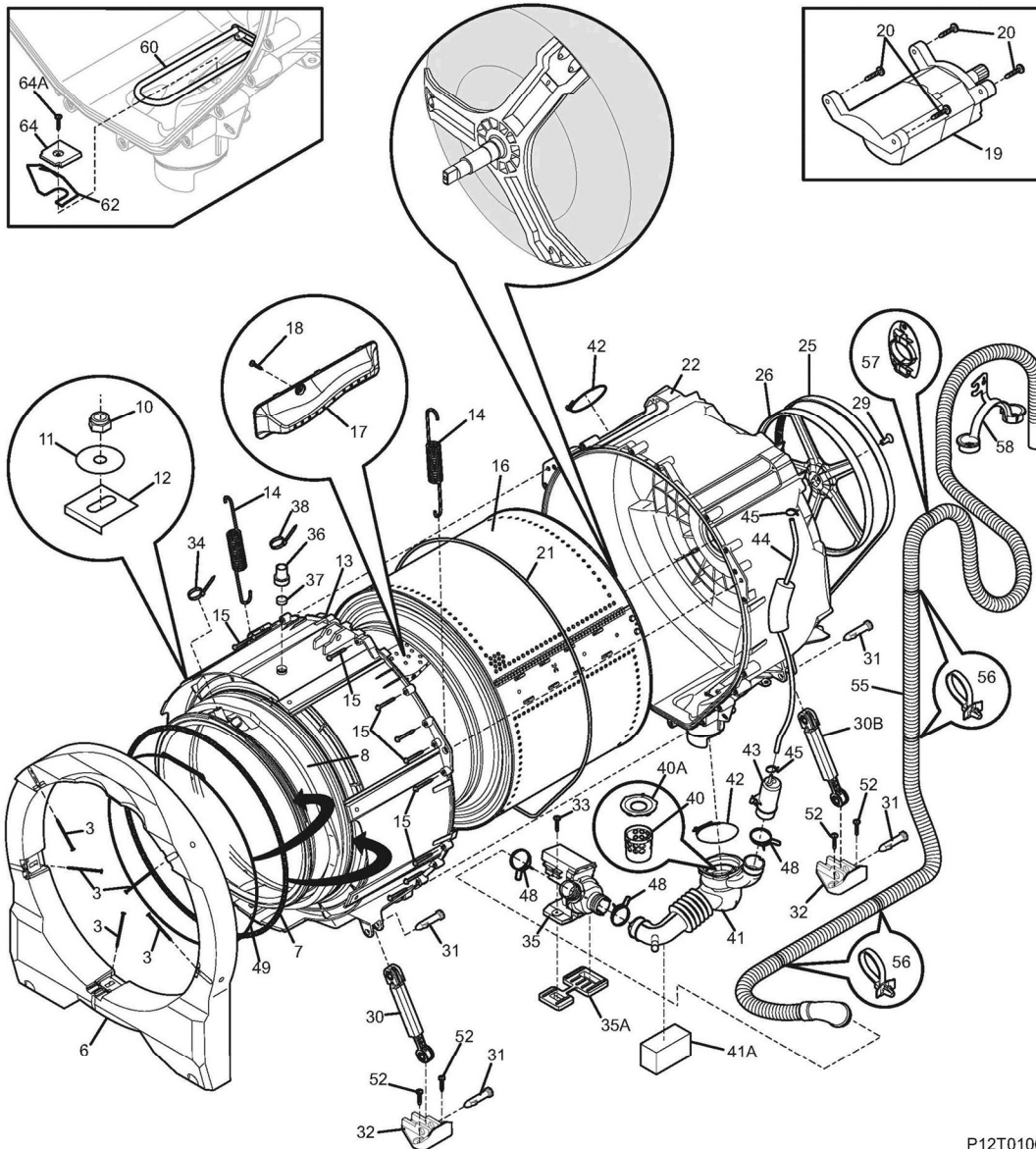

P12T0106

09/13

6

Guía	Descripción	Número
3	BOLT	131793303
6	COUNTERWEIGHT	134362210
7	Door Boot Spring	134365300
8	Bellow Kit	134515300
10	NUT	137086500
11	WASHER	131276900
12	Plate,counterweight	134430600
13	SHELL	134955100
14	Suspension Spring	134957000
15	SCREW	131303900
16	DRUM Assembly	134950400
17	Drum Baffle	134952702
18	Screw	131302800
19	MOTOR	134638900
20	SCREW	131303500
21	Washer Outer Tub Gasket (O RING)	5304520351
22	SHELL	134956210
25	Drive Belt	134616700
26	Idler Pulley	5304506264
29	Screw,10.9 class ,M10 x 25 mm	134408400
30	Shock Absorber Kit	5304491701
30B	Shock Absorber Kit	5304491700
31	Single Shock Mounting Pin	131268300
32	BRACKET	134363200
33	SCREW	134637200
34	WIRE TIE	5304464772
35	PUMP	137311900
35A	PAD	134618100
36	HOSE	137322400
37	SCREEN	137322500
40	FILTER	134640200
40A	Filter Cover	134640300
41	Tub to Pump Hose	134639920
41A	Foam Vibration Damper	137340800
42	Hose Clamp	134737300
43	CHAMBER	134636800

Guía	Descripción	Número
44	AIR CHAMBER,PRESSURE HOS	137089000
45	CLAMP	137087500
48	Clamp	131306234
49	Spring-Held Bellow Clamp	134527100
52	SCREW	131202300
55	HOSE	137628100
56	CABLE TIE	137003500
57	BRACKET	134641100
60	Heating Element - 1000W	137488301
62	SUPPORT	134642300
64	SUPPORT	134644600



LAVADORA FFFWS5100PW0

Publication No: 5995636916

FFFWS5100PW0

WIRING DIAGRAM

