

Distribuidor Autorizado

SurteRápido.com

Venta de Refacciones
Electrodomesticas

FPD14TLL0 DOOR

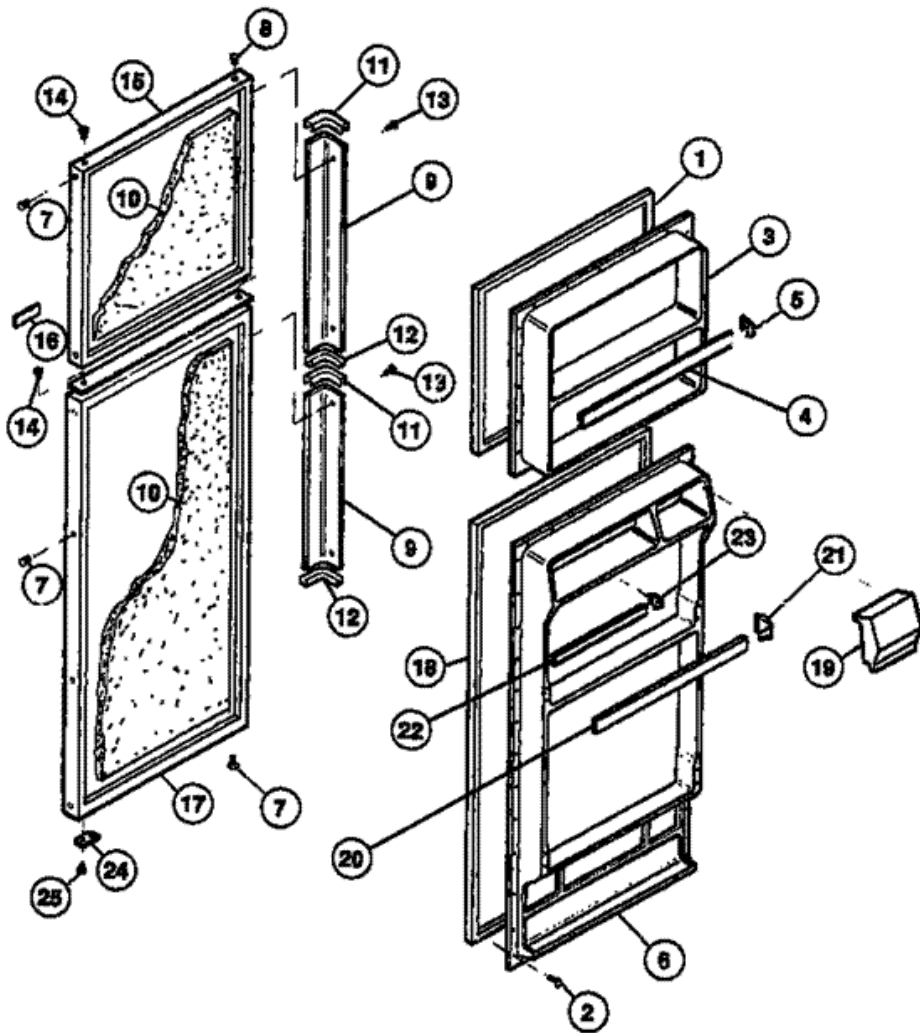



FPD14TLL0 DOOR

1	5303288856	GASKET-FREEZER
2	5303001001	SCREW-MTG (54) (S/P)
3	5304409402	INNER PANEL-FREEZER DESCONTINUADO
4	5308013640	DOOR RACK (2) (S/P)
5	5303017377	SUPPORT-RH (2)
6	5304409402	INNER PANEL-REFR DESCONTINUADO
7	5308000181	PLUG-HANDLE, ALMOND (S/P)
8	5303001308	PLUG-HINGE, ALMOND (S/P)
9	5303017190	HANDLE ASSY-W/ TRIM & END CAPS (2) (S/P)
10	5303917276	INSULATION (BULK) (S/P)
11	5308010239	END CAP-TOP (2) (S/P)
12	5308010238	END CAP-BTM (2) (S/P)
13	5308013645	SCREW-HANDLE MTG (4) (S/P)
14	218519300	BEARING-HINGE (8) (S/P)
15	3916046	OUTER PANEL-ALMOND (S/P)
16	3201526	NAMEPLATE (S/P)
17	3916051	OUTER PANEL-ALMOND DESCONTINUADO
18	215732461	GASKET-REFR
19	5303304048	DAIRY DOOR DESCONTINUADO
20	215516220	DOOR RACK (2) (S/P)
21	5303323482	SUPPORT-RH (2) (S/P)
22	5308013640	DOOR RACK (S/P)
23	5303017377	SUPPORT-RH
24	5308000255	DOOR STOP (2) (S/P)
25	5308011745	SCREW (2) (S/P)
5A	5303323481	SUPPORT-LH (2) (NON-ILLUSTRATED)
21A	5303323483	SUPPORT-LH (2) (NON-ILLUSTRATED)
23A	5303323481	SUPPORT-LH (NON-ILLUSTRATED)

Distribuidor Autorizado

SurteRápido.com

Venta de Refacciones
Electrodomesticas

FPD14TLL0 CABINET

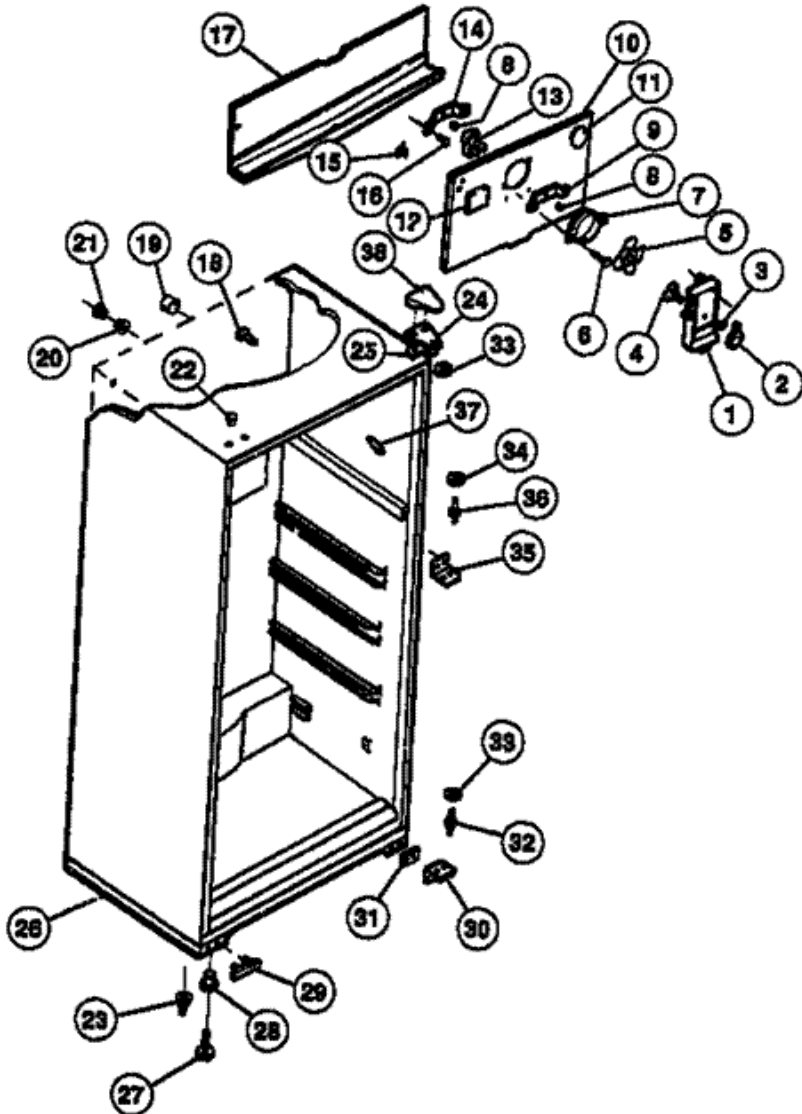



FPD14TLL0 CABINET

1	5304404597	COVER-FAN (S/P)
2	5308009793	KNOB-DAMPER CONTROL (S/P)
3	5303212803	PUSHNUT (S/P)
4	5303001331	DAMPER-FAN (S/P)
5	5308000010	FAN BLADE (S/P)
6	5303001001	SCREW-FAN ASSEMBLY (2) (S/P)
7	5308000124	ORIFICE RING (S/P)
8	5300157666	BUSHING (2) (S/P)
9	5304414684	BRACKET-FRONT (S/P)
10	3001358	COVER-EVAPORATOR COIL (S/P)
11	5303203044	PLUG-SHORT TEST HOLE (S/P)
12	5308013636	PLUG-DECORATIVE DESCONTINUADO
13	5300158289	MOTOR-FAN (S/P)
14	5303322992	BRACKET-REAR (S/P)
15	5308000107	BRACKET-CONNECTOR (S/P)
16	5303001001	SCREW-BRACKET MOUNTING (S/P)
17	8003638	DRAIN TROUGH DESCONTINUADO
18	215245000	SUPPORT-COIL COVER (2) (S/P)
19	218631200	TUBE-RUBBER (2) DESCONTINUADO
20	5303001286	FERRULE-INNER (S/P)
21	5303001287	FERRULE-OUTER (S/P)
22	5303001389	PLUG-ALMOND (2) (S/P)
23	5303001386	DRAIN TUBE (S/P)
24	5308012843	HINGE-TOP (S/P)
25	5303001037	SHIM-TOP HINGE (S/P)
26	5303006086	CABINET BASE (S/P)
27	5303205540	LEVELING SCREW (2) (S/P)
28	5308003584	ANCHOR NUT (2) (S/P)
29	5303001478	PLUG-HINGE HOLE (S/P)
30	5303202834	BRACKET-BOTTOM HINGE (S/P)
31	5303001323	SHIM-BOTTOM HINGE (S/P)
32	5303001321	PIN-BOTTOM HINGE (S/P)
33	5308000007	WASHER-1/4 NYLON (2) (S/P)

34	5308000186	WASHER-NYLON (S/P)
35	5303001369	BRACKET-CENTER HINGE (S/P)
36	5308000184	PIN-CENTER HINGE (S/P)
37	8003618	CORNER TRIM-ALMOND (4) (S/P)
38	5308012933	HINGE COVER-ALMOND (S/P)
10B	5308016566	SCREW-COVER MTG (NON-ILLUSTRATED) (S/P)
*31281	5308016571	PLUG-FREEZER LINER (8) (S/P)
2A	8009823	LABEL-KNOB (NON-ILLUSTRATED) (S/P)
30A	5303001320	SCREW-HINGE MOUNTING (2) (S/P)
24A	5303001479	SCREW-HINGE MTG (2) (S/P)
1A	5308016566	SCREW-COVER MOUNTING (2)
35A	5308012258	SCREW-HINGE MOUNTING (2) (S/P)
*31281	5308012296	TAPPING PLATE (4) (S/P)
10A	5308000126	NUT-U-TYPE (2) (S/P)

Distribuidor Autorizado

SurteRápido.com

Venta de Refacciones
Electrodomesticas

FPD14TLL0 SHELVES

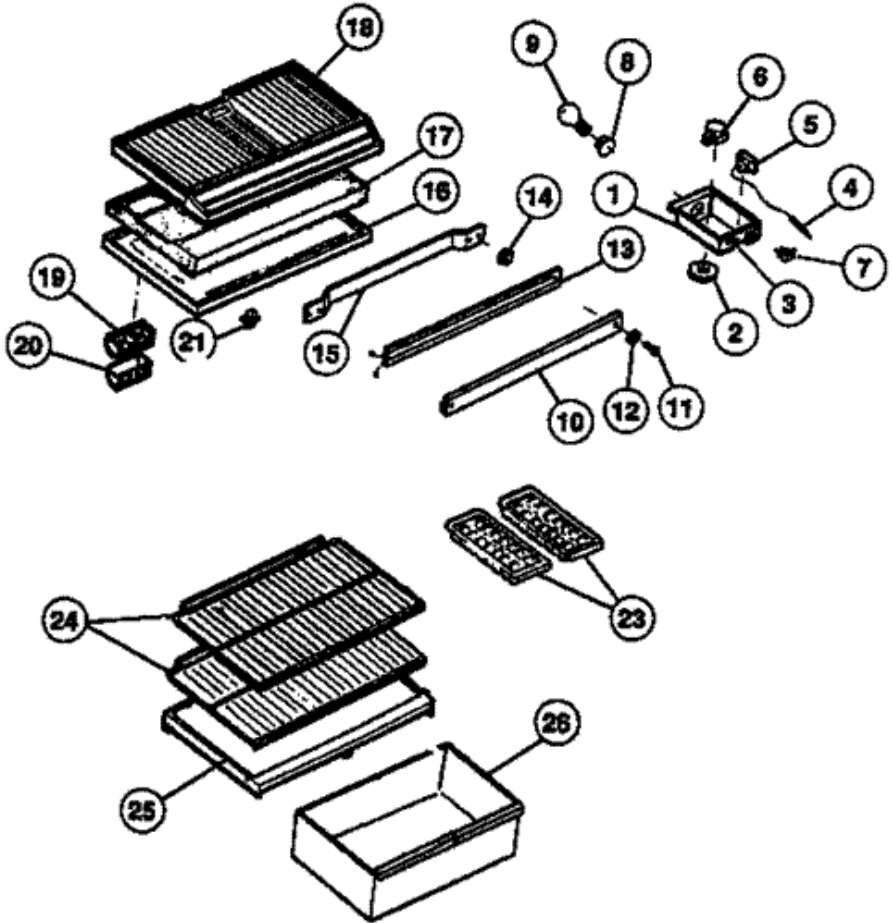



FPD14TLL0 SHELVES

1	5308009730	CONTROL BOX (S/P)
2	8006978	KNOB-TEMP CONTROL DESCONTINUADO
3	8006988	LABEL-CONTROL BOX (S/P)
4	5303916855	SLEEVE-PLASTIC (S/P)
5	5308015762	CONTROL-TEMPERATURE
6	215846602	TIMER-DEFROST
7	5308016615	SLIDE-SWITCH
8	5308000129	LIGHT SOCKET
9	5303013071	LIGHT BULB (S/P)
10	5303916134	MULLION-ALMOND (S/P)
11	5308012258	SCREW-MULLION (4) (S/P)
12	5303206754	WASHER-NO. 10 STEEL (2) (S/P)
12	5303201079	HEAT EXCHANGER (S/P)
13	5308017408	HEATER-MULLION (S/P)
14	3001370	SPACER-MULLION (2) (S/P)
15	215170801	STRAP-MULLION MTG (S/P)
16	5303917935	TOP PANEL-REFR (S/P)
17	5308000759	DIVIDER-STYROFOAM DESCONTINUADO
18	5308000748	BOTTOM PANEL-FRZR (S/P)
19	5308000071	AIR DEFLECTOR (S/P)
20	5303001546	COVER-DEFLECTOR (S/P)
21	5309918806	LIGHT SWITCH (S/P)
23	1121808	ICE CUBE TRAY (2) (S/P)
24	5303304685	SHELF-REFR (2) DESCONTINUADO
25	5308000749	COVER-PAN (S/P)
26	5308000977	PAN-STORAGE (S/P)
17A	3001383	WIRING HARNESS-DIVIDER (S/P)
6A	5303001259	SCREW-TIMER MTG (2) (S/P)
5A	5303001260	SCREW-CONTROL MTG (2) (S/P)
16A	5303001380	SCREW-PANEL MTG (3) (S/P)
1A	5308016566	SCREW-BOX MTG (S/P)

Distribuidor Autorizado

SurteRápido.com

Venta de Refacciones
Electrodomesticas

FPD14TLL0 SYSTEM

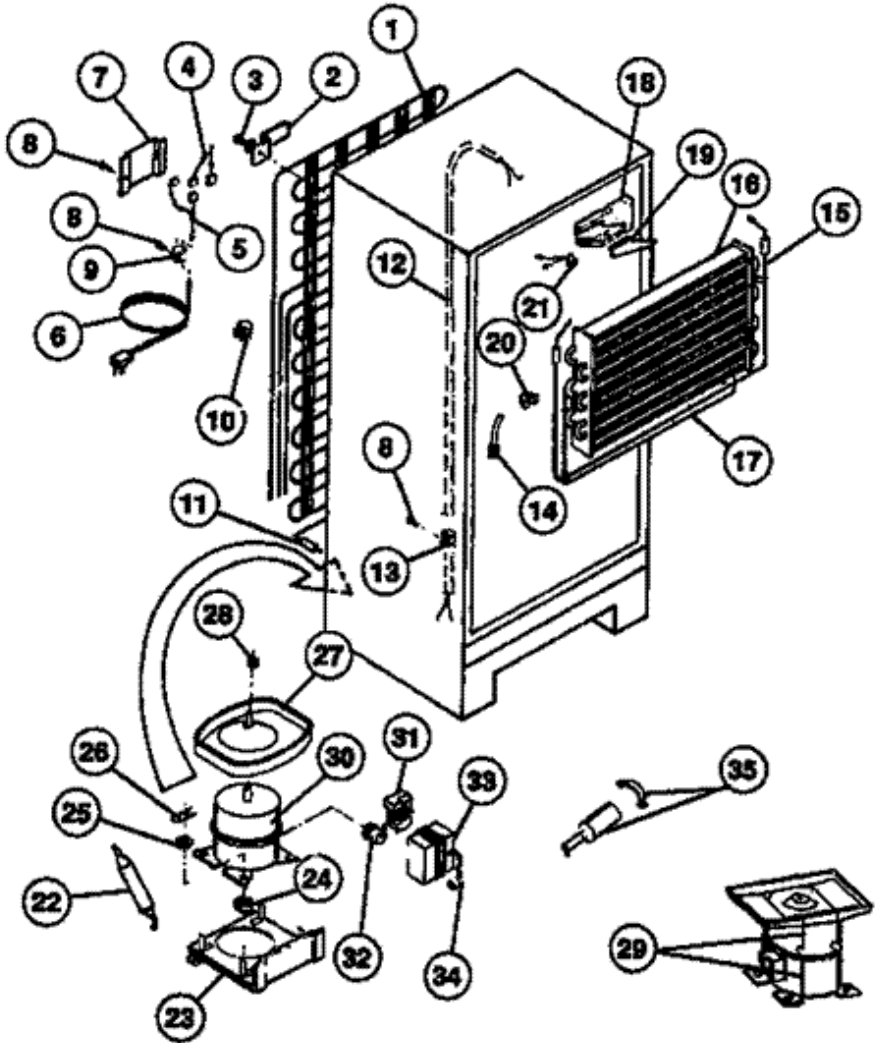



FPD14TLL0 SYSTEM

1	218491000	CONDENSER (S/P)
2	5308000296	BRACKET-COND MTG (4) (S/P)
3	5308000039	SCREW-8-32 X 1/2 (S/P)
4	3001383	WIRING HARNESS-CONTROL (S/P)
5	5303271882	WIRING HARNESS-COMPR DESCONTINUADO
6	5316254901	SERVICE CORD DESCONTINUADO
7	5303001197	COVER-WIRING (S/P)
8	5303001343	SCREW-8-15 X 1/2 (S/P)
9	5303001199	CLAMP (S/P)
10	5308000133	CLAMP-NYLON (S/P)
11	5303017691	SPACER-TUBE (S/P)
13	5308000133	CLAMP-TUBE (S/P)
14	5308000110	STRAP-HEATER/EVAP (2) (S/P)
15	5303001362	HEATER-DEFROST (S/P)
16	5303272044	EVAPORATOR COIL (S/P)
17	5316651102	INSULATOR-COIL (S/P)
18	5308013648	INSULATION BLOCK-RH (S/P)
19	5303007287	INSULATION PLUG-RH (S/P)
20	5308017227	INSULATION BLOCK-LH (S/P)
21	5303917954	THERMOSTAT-DEFROST
22	5303305677	DRIER-FILTER (S/P)
23	5308009596	PLATE-COMPR MTG (S/P)
24	5308008778	GROMMET (4) (S/P)
25	5308003633	WASHER (3) (S/P)
26	5308003596	CLIP (3) (S/P)
27	5303917590	DRAIN PAN-DEFROST-SVCE COMPR (S/P)
28	5303001348	LOCK NUT-PAN MTG (S/P)
29	5303916001	PAN RETAINER KIT-SERVICE COMPR (S/P)
30	5304428317	COMPRESSOR W/ DESCONTINUADO
31	5303007173	RELAY
32	3202863	OVERLOAD DESCONTINUADO
33	8016583	COVER-TERMINAL (S/P)
34	8016584	STRAP-COVER MTG (S/P)

35	5303018427	CAPACITOR-COMP RUN DESCONTINUADO
3A	5308009617	WASHER-NO. 10 EXT TOOTH LOCK (S/P)
27B	5308017610	SOUND TAPE-PAN (NON-ILLUSTRATED) (S/P)
*31285	3018428	STRAP-CAPACITOR MTG DESCONTINUADO
22A	3201679	CLAMP-DRIER (NON-ILLUSTRATED) (S/P)
32A	3202891	CLIP-OVERLOAD (NON-ILLUSTRATED) (S/P)
27A	5300171129	DRAIN PAN-DEFROST-ORIG COMPR
*31285	5300189377	HOT TUBE REPAIR KIT-SERVICE DESCONTINUADO
22B	5303001001	SCREW-CLAMP (S/P)