

FTF530FS0 TABLERO

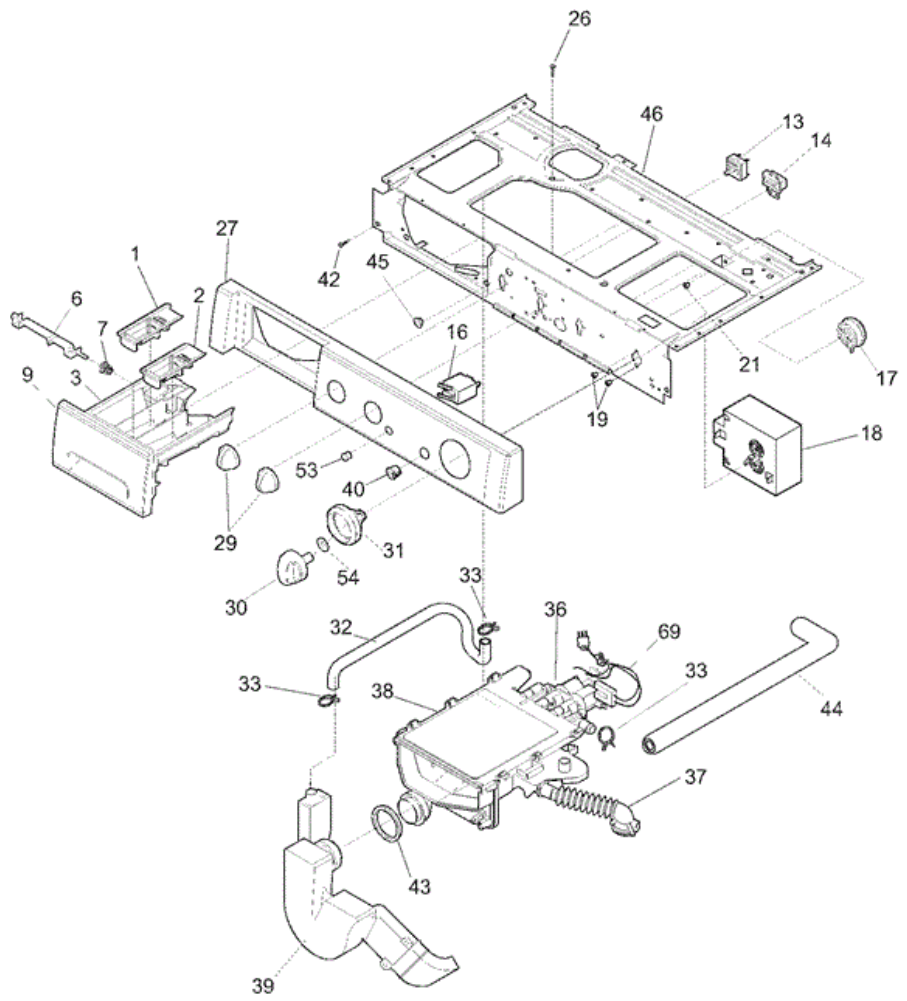



FTF530FS0 TABLERO

1	131272100	COVER-BLEACH
2	131272000	COVER-SOFTENER
3	131271910	DRAWER,DISPENSER
6	131374500	LATCH,DISP DRAWER HDL
7	131427500	SPRING
9	131691267	HANDLE,DISPENSER ,WITH TRIM
19	131243800	SCREW,PAN HD LOCKING ,8-32CA X 0.375 ,CUP POINT
21	131243700	SCREW, PAN HEAD, 8-18AB X 0.375
26	131823400	SCREW,8-18 X 2.00
27	131887207	CONSOLE,FRAME/TRIM ASSY
29	131761704	KNOB,ROTARY ,WHITE/DARK GRAY
30	134191800	KNOB,TIMER
31	131853900	POINTER,TIMER ,WHITE ,GRAY INDICATOR
32	131786100	HOSE,SIPHON/VALVE
33	131306216	CLAMP
37	131271600	HOSE-TUB
39	131863300	SIPHON
42	131168200	SCREW,PAN HEAD ,8-18B X 0.31
43	131749200	GASKET-SEAL
44	131786000	HOSE-DISPENSER
45	5303321107	BUSHING,IDLER
46	134191412	PANEL,CONTROL MTG. ,WING BEND
53	131724800	LENS,STATUS LIGHT ,CLEAR
54	5308015493	SPACER,WASHER ,TIMER SHAFT
F13	134397500	SWITCH,TEMPERATURE ,3 POSITION
F14	134126700	BUZZER,ADJUSTABLE
F16	131724700	LAMP,STATUS LIGHT
F17	134438301	SWITCH,PRESSURE ,WATER OPTIMIZER
F18	134378400	TIMER
F36	131974700	VALVE,DISPENSER ,W/SEAL
F38	131803710	DISPENSER ASSY
F40	134040800	SWITCH,ON/OFF ,WHITE ,ROUND
F69	134547500	WIRING HARNESS,MAIN

NI	131307900	CLAMP,SIPHON/BELLOWS
NI	131931201	DAMPENER,VIBRATION ,3.5 X 2 X 2 IN. ,FOAM

FTF530FS0 GABINETE

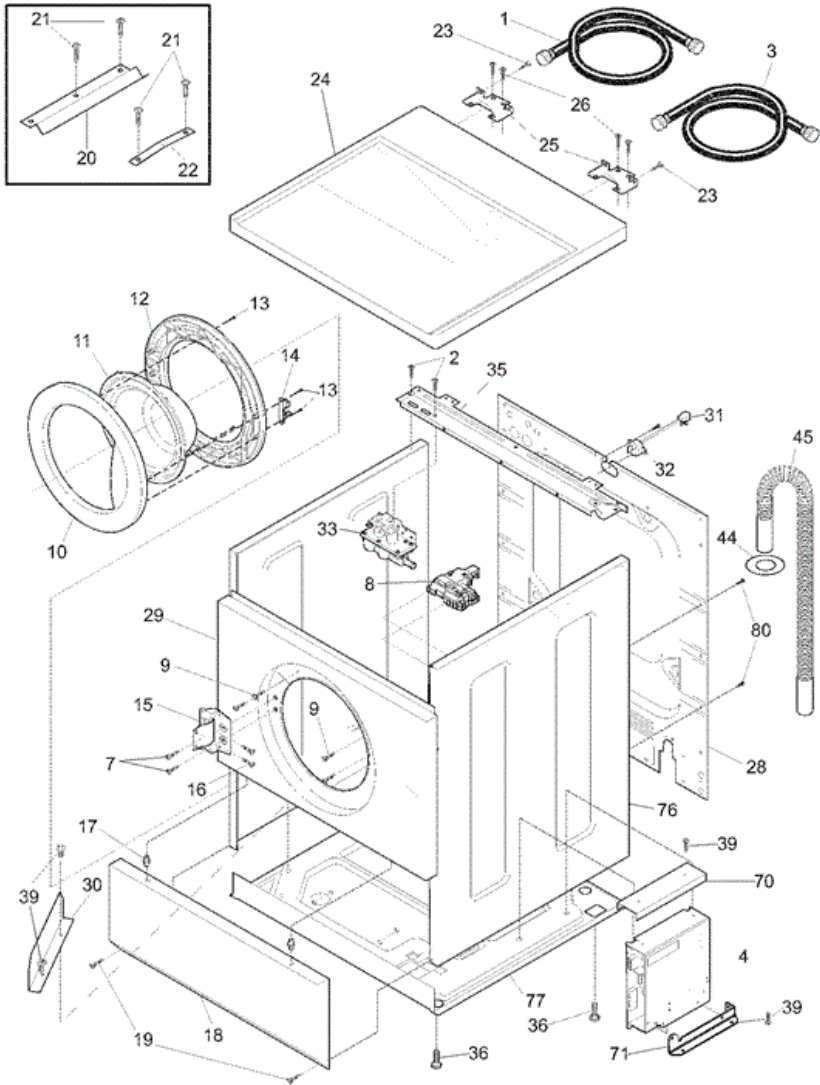



FTF530FS0 GABINETE

1	131279602	HOSE,WATER INLET ,COLD
2	131168200	SCREW,PAN HEAD ,8-18B X 0.31
3	131279603	HOSE,WATER INLET ,HOT
7	131205300	SCREW,10-16 X 0.750
9	131303300	SCREW,PAN HEAD ,10-16AB X 0.500 ,LOCKING
10	131278700	FRAME,OUTER DOOR ,WHITE
11	131278800	PANEL,DOOR GLASS
12	131278900	FRAME,INNER DOOR ,WHITE
13	131302901	SCREW,10-16 X 0.750
14	131763310	STRIKER,DOOR/LOCK/SW
15	134264600	HINGE,DOOR
16	131696300	SCREW,QUAD PAN HEAD ,10-16 X 0.312
17	131346400	PIN,PANEL LOCATOR
18	131279300	PANEL,SERVICE ,WHITE ,FRONT
19	131358400	SCREW,HEX WASHER HD ,8-18AB X 1.125
20	131460900	BRACKET,TOP PANEL MTG. ,FRONT
21	131243700	SCREW, PAN HEAD, 8-18AB X 0.375
22	131279500	RETAINER,SPRING STEEL
23	131243800	SCREW,PAN HD LOCKING ,8-32CA X 0.375 ,CUP POINT
24	134086842	PANEL,WHITE ,TOP
25	131668200	BRACKET,TOP PANEL MTG.
26	134178901	SCREW,8-18AB X 0.455
28	131978500	PANEL-BACK
29	131752030	PANEL,CABINET FRONT ,WHITE
30	131859600	SHIELD-OVERFLOW
32	5303209428	BUSHING,POWER CORD
35	131732902	BRACKET,REINFORCEMENT ,TOP REAR
36	131841600	LEVELING LEG ASSY,BOLT,PAD & NUT
39	134178900	SCREW,QUAD ,8-18AB X 0.455
44	131707800	RING-DRAIN HOSE
70	134048600	SHIELD,DRIP PROTECTOR
71	134048400	BASE,CONTROLLER MTG
76	134390701	PANEL,SIDE ,WHITE ,RS/LS ,(2)

77	131458240	BASE PLATE
80	134547800	SCREW,10-16AB X 0.375
F31	134501000	POWER CORD,ELECTRIC SVCE
F33	5303207418	VALVE-WATER
F4	134149200	CONTROLLER ASSY,SPEED ,W/BASE & SHIELD
F45	134592700	HOSE,DRAIN
F8	131763245	DOOR LOCK/SWITCH ASSY
NI	5303937142	SHIPPING BRACE KIT

Distribuidor Autorizado

SurteRápido.com

Venta de Refacciones
Electrodomesticas

FTF530FS0 TINA

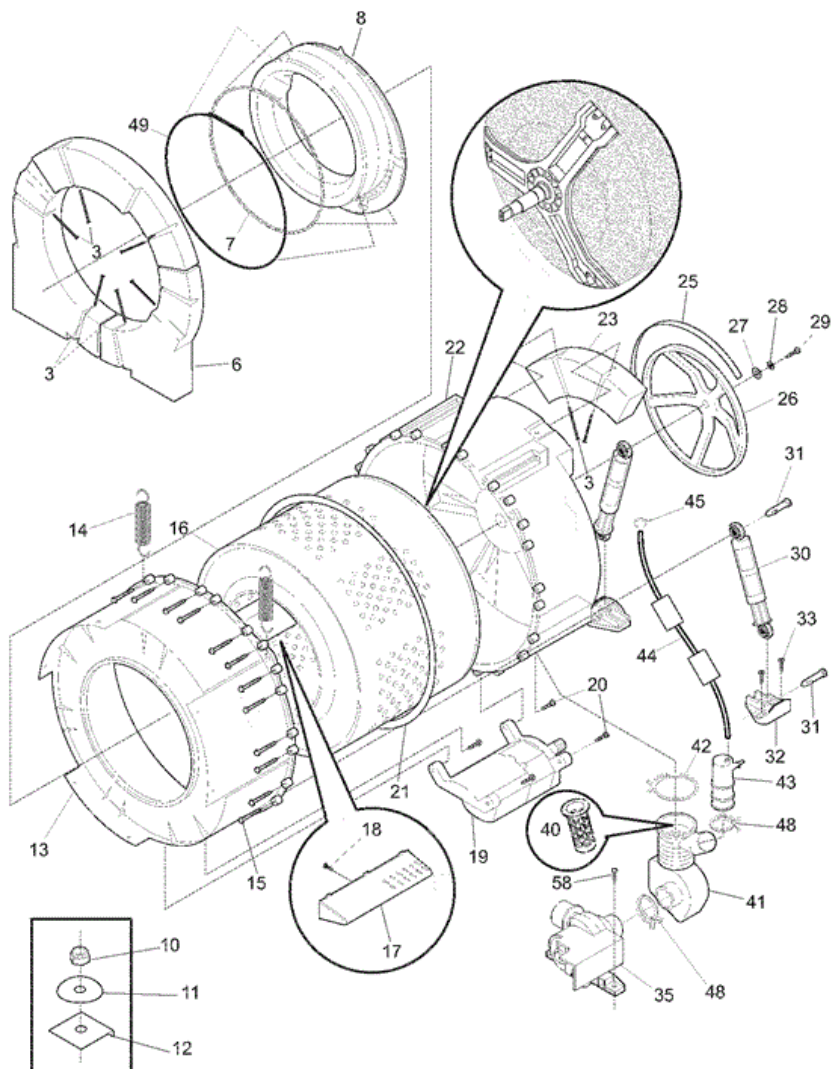



FTF530FS0 TINA

3	131793302	BOLT,CARRIAGE ,1/4-20 X 4.00
6	131975300	COUNTERWEIGHT,ONE PIECE
7	131277300	SPRING,BOOT RETAINER
8	134177600	BELLOWS,DOOR BOOT
10	131304700	NUT,HEX ,1/4-20 UNC-2B ,(2)
11	131276900	WASHER,BELLVILLE ,SPRING STEEL
12	131793500	PLATE,COUNTERWEIGHT
13	131618600	SHELL,OUTER TUB ,FRONT
14	134144700	SPRING ASSY,SUSPENSION ,W/SLEEVES
15	131303900	SCREW,HEX WASHER HEAD ,1/4-10A X 2.165
16	131618500	DRUM ASSY,SPIN BASKET
17	131274600	VANE
18	131302800	SCREW,10-16AB X 0.375
20	131303500	SCREW,12-14AB X 1.50 ,MOTOR MTG.
21	134146100	O-RING-TUB
22	131462800	SHELL,OUTER TUB ,REAR ,WITH BEARING
23	134125900	COUNTERWEIGHT,DRUM REAR
27	131304400	WASHER,0.41 X 1.50 ,0.12 THICK
28	131304500	WASHER-LOCK,3/8
29	131303700	SCREW,PULLEY MTG. ,M10 X 0.92 ,METRIC
30	131268200	SHOCK ABSORBER,AIR ,STABILIZER
31	131268300	PIN,SHOCK MTG.
32	131268100	BRACKET,SHOCK MTG.
33	134532200	SCREW,10-16AB X 0.500
40	134565200	FILTER,PUMP
41	134044200	HOSE-COIN TRAP-TUB TO PUMP
42	131333101	CLAMP
43	131277500	CHAMBER-AIR
44	131277600	HOSE,AIR PRESSURE
45	131306202	CLAMP,HOSE
48	131306234	CLAMP,HOSE ,WIRE
49	134266500	CLAMP,BELLOWS/BOOT ,0.059 OD WIRE ,
58	134160900	SCREW,QUADREX ,10-16AB X 0.750

F19	131770600	MOTOR
F25	134051000	BELT,DRIVE ,6-RIB
F26	131883400	PULLEY,DRUM DRIVE ,LARGE ,REAR
F35	134051100	PUMP,DRAIN
NI	131560000	SLEEVE,PROTECTOR ,LWR SPRING HOOK
NI	131592200	SLEEVE,PROTECTOR ,UPR SPRING HOOK
NI	134763700	ENERGY GUIDE