

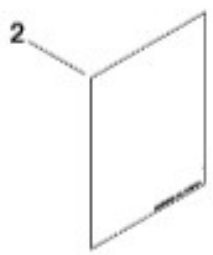

SECADORA GTMP520ED5WW

SISTEMA CONTROLES / CONTROL SYSTEM

GTMP520ED5WW

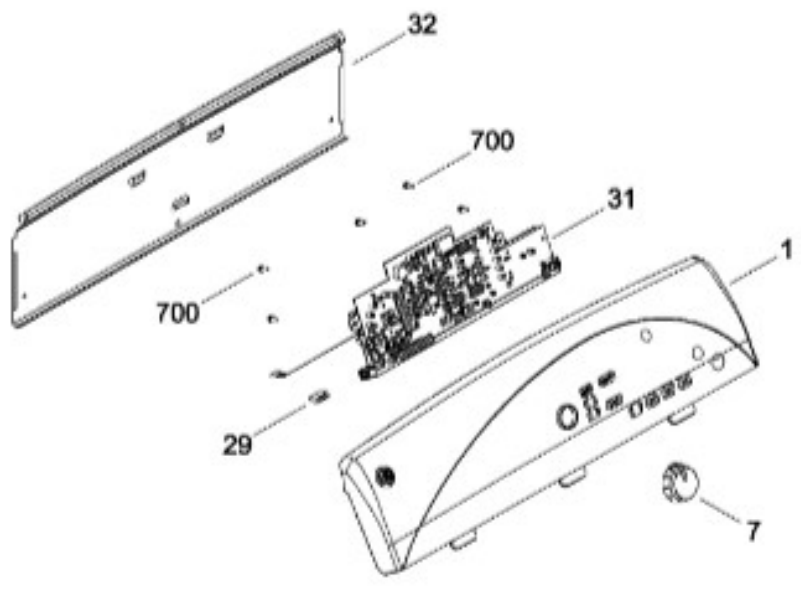

BENITO JUÁREZ #1500 GPE ZITON, CD. GUADALUPE NUEVO LEÓN TEL: 8183377999 Y 49
HORARIOS: LUNES A VIERNES 8:30 A 6:00 PM Y SÁBADOS DE 8:30 A 2:00 PM
WEB: www.denek.com



SECADORA GTMP520ED5WW

PANEL FRONTAL (ENS) / FRONT PANEL (ASM)
PUERTA (ENS) / DOOR (ASM)

GTMP520ED5WW

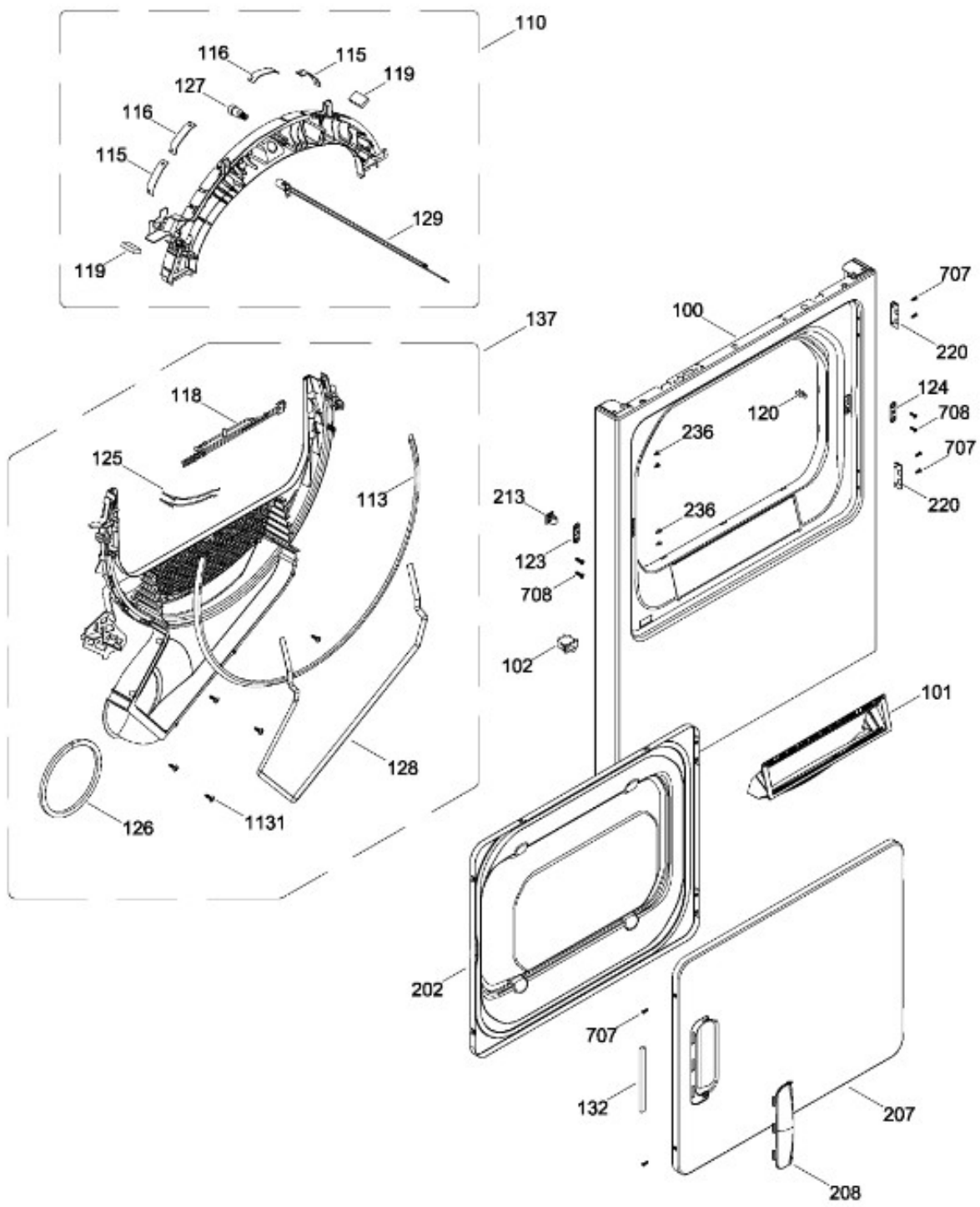

BENITO JUÁREZ #1500 GPE ZITON, CD. GUADALUPE NUEVO LEÓN TEL: 8183377999 Y 49
HORARIOS: LUNES A VIERNES 8:30 A 6:00 PM Y SÁBADOS DE 8:30 A 2:00 PM
WEB: www.denek.com



SECADORA GTMP520ED5WW

GABINETE / STRUCTURE

GTMP520ED5WW

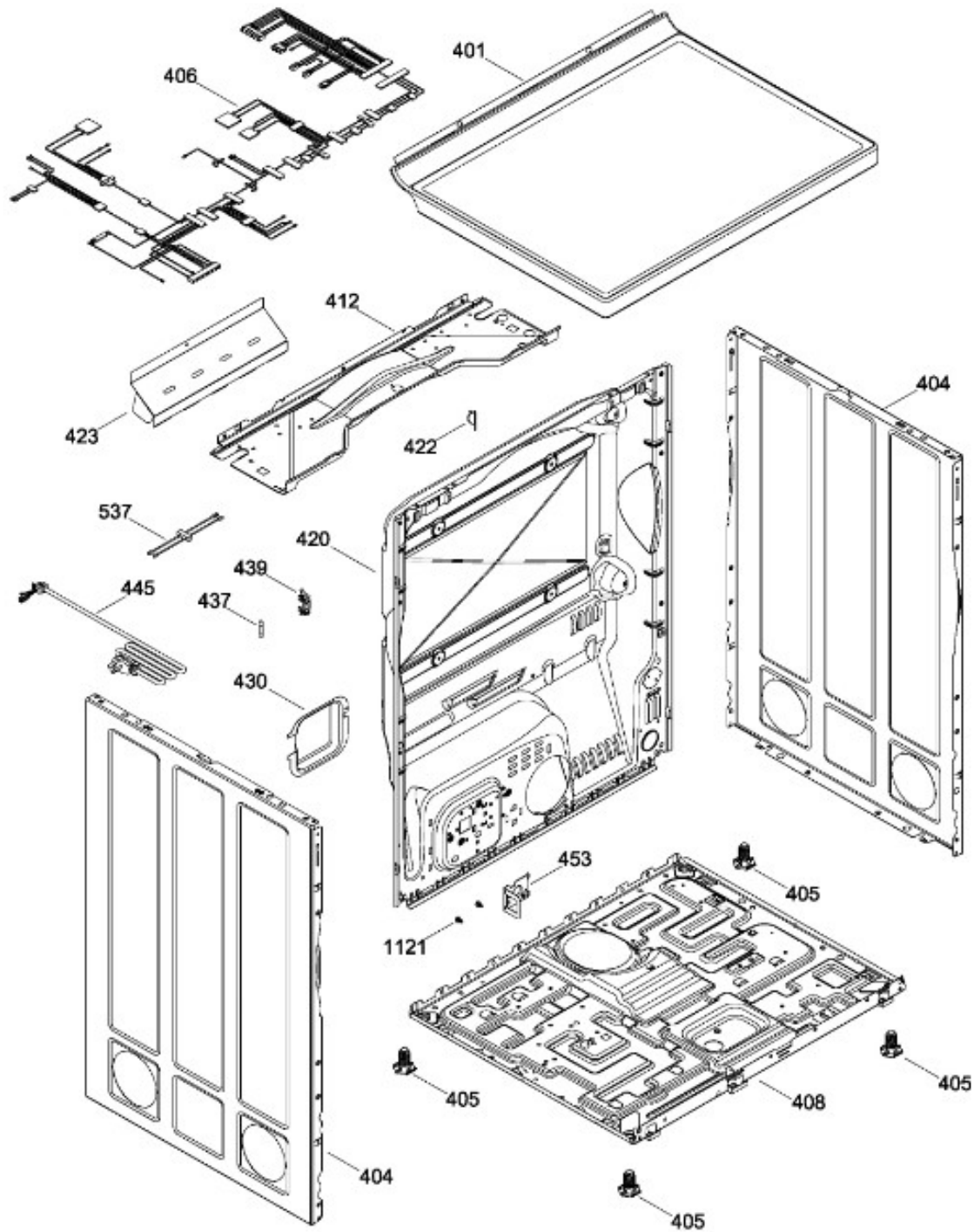

BENITO JUÁREZ #1500 GPE ZITON, CD. GUADALUPE NUEVO LEÓN TEL: 8183377999 Y 49
HORARIOS: LUNES A VIERNES 8:30 A 6:00 PM Y SÁBADOS DE 8:30 A 2:00 PM
WEB: www.denek.com



SECADORA GTMP520ED5WW

SISTEMA DE TRANSMISION (ENS) / BLOWER & DRIVE (ASM)

GTMP520ED5WW

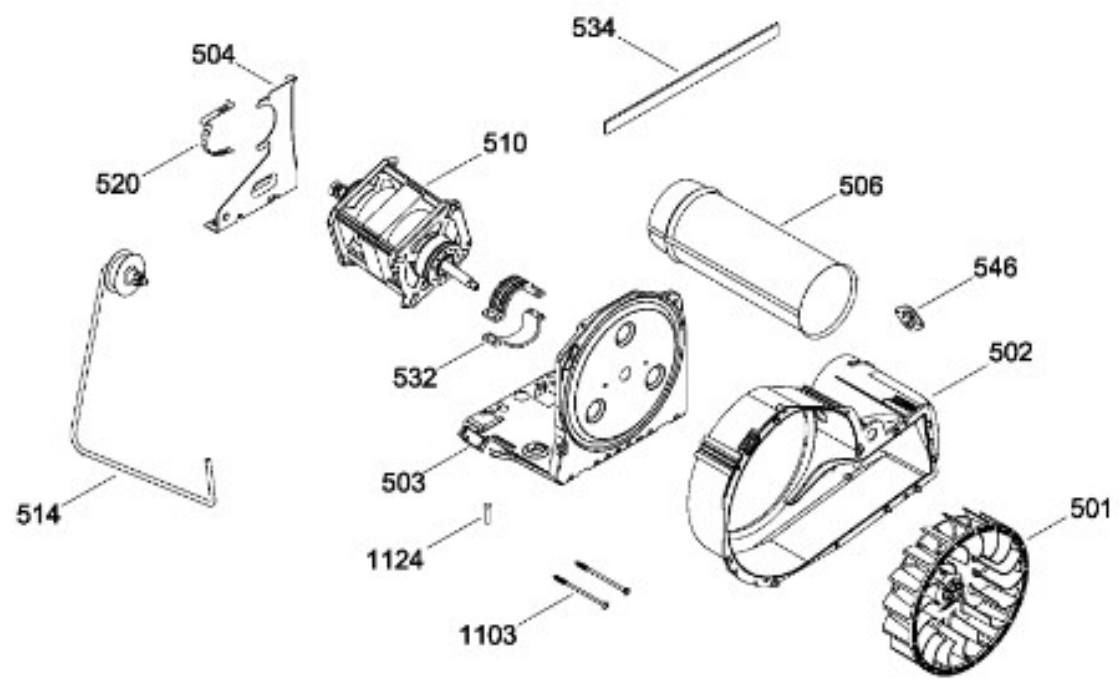

BENITO JUÁREZ #1500 GPE ZITON, CD. GUADALUPE NUEVO LEÓN TEL: 8183377999 Y 49
HORARIOS: LUNES A VIERNES 8:30 A 6:00 PM Y SÁBADOS DE 8:30 A 2:00 PM
WEB: www.denek.com

Guía	Refacción	Descripción
1	WW02L00299	ENSAMBLE COPETE
2	WW01A00583	MANUAL DE USO Y CUIDADOS
7	WW02L00258	PERILLA ENSAMBLE
29	WW02F00297	HARNESS JUMPER
31	WW02F00277	BOARD ASM. MOUNTED
32	WW02L00152	BACK PANEL
100	WW03L00330	PANELFRONTAL
101	WW02L00080	ENS. FILTRO MALLA
101	WW02F00616	ENS. FILTRO MALLA
102	WW02L00025	INTERRUPTOR PUERTA
110	WW02A00158	COJINETE SUPERIOR ENS
110	WW02L00517	COJINETE SUPERIOR ENS
113	WW01L01329	FELPA COLECTOR DE AIRE
113	WW02F00783	FELPA COLECTOR DE AIRE
115	WW03A00015	COJINETE DESLIZABLE
116	WW03A00016	COJINETE DESLIZABLE
116	WW02A00250	COJINETE DESLIZABLE
118	WW02F00094	ARNES SENS.OR
119	WW02F00131	FIELTRO
119	WW02F00784	FIELTRO
120	WW02A00004	STRIKE
123	WW02A00056	STRIKE PLATE
124	WW02A00057	STRIKE PLATE
125	WW02F00088	SENSOR ROD
126	WW02L00040	GASKET FOAM
127	WW03F00458	LAMPARA
128	WW03F00354	SELLO
129	WW01F01584	ENSAMBLE CLAVIJA
132	WW02L00427	SELLO
137	WW01F01598	ENSAMBLE COLECTOR DE AIRE
137	WW02F00591	ENSAMBLE COLECTOR DE AIRE
202	WW03L00333	PUERTA INTERIOR ENSAMBLE
207	WW03L00308	PANELDEPUERTA
208	WW03L00310	JALADERA PUERTA
208	WW03L00310	JALADERA PUERTA

Guía	Refacción	Descripción
213	WW02L00037	LATCH ASM.
220	WW02L00029	BISAGRA
220	WW02L00028	BISAGRA
236	WW02A00065	BOTON BELLEZA
401	WW03L00302	CUBIERTA SUPERIOR
404	WW02L00269	SIDE PANEL WHITE
405	WW02L00244	PATA NIVELADORA
406	WW01F01599	ARNES ENSAMBLE ELECTRICO
408	WW03L00314	BASECHASIS
412	WW03L00247	CUBIERTA INFERIOR
420	WW03L00294	PANEL POSTERIOR
422	WW02F00022	CORD SET RETAINER
423	WW02L00107	ESCUDO CALOR POST.
430	WW02L00211	CUBIERTA TERMINAL FUSIBLE
437	WW03F00460	FUSIBLE
439	WW03F00459	PORTAFUSIBLE
445	WW03F00109	CORDON TOMACORRIENTE(240V CA)
453	WW01A00535	SOPORTE ANTI TENSION
501	WW01F01162	VENTILADOR REDONDO
502	WW02L00429	SOPLADOR CUBIERTA
503	WW03L00293	BASEMOTOR
504	WW02F00027	SOPORTE MOTOR
506	WW01F01581	DUCTODEESCAPE
506	WW02L00148	DUCTODEESCAPE
506	WW02L00148	CONDUCTO DE ESCAPE
510	WW02F00015	MOTOR POLEA ENS.
510	WW03A00209	MOTOR POLEA ENS.
514	WW03F00350	ENSAMBLE BRAZO TENSOR
520	WW02F00031	CLIP MOTOR
532	WW02F00003	CORREA MOTOR
532	WW02A00232	CORREA MOTOR
534	WW02A00026	EMPAQUE ESCAPE SOPLADOR
534	WW02F00785	EMPAQUE ESCAPE SOPLADOR
537	WW03F00179	ARNES PORTAFUSIBLE
546	WW02F00334	TERMISTOR DE CONTROL DE SALIDA

Guía	Refacción	Descripción
600	WW02F00478	TAMBOR ENSAMBLE
610	WW03F00351	BANDA
610	WW02F00028	BANDA
610	WW02F00854	BANDA SECADORA
617	WW03L00152	CUBIERTA CALENTADOR
617	WW03L00152	CUBIERTA CALENTADOR
619	WW01A00442	SOPORTE DE PROTECCION
620	WW02L00421	ALETA
623	WW01F01596	ARNES TERMOSTATO ENSAMBLE
625	WW03F00180	CALENTADOR ENS
626	WW02F00221	DIFUSOR
626	WW02F00827	DIFUSOR
630	WW02A00019	SOPORTEYFLECHAENSAMBLE
635	WW02F00468	CALENTADOR Y CUBIERTA ENSAMBLE
637	WW02A00005	RETENEDOR RODAMIENTO
640	WW01A00443	GROUND STRAP ASSEMBLY
640	WW02F00833	GROUND STRAP ASSEMBLY
700	WW01A00582	TORNILLO
707	WW01A00539	TORNILLO
708	WW02A00098	SCREW
708	WW01A00539	SCREW
1103	WW02A00032	TORNILLO
1120	WW02A00031	TORNILLO
1121	WW01A00001	TORNILLO
1124	WW02A00070	TORNILLO
1127	WW01A00521	TORNILLO
1127	WW02A00211	TORNILLO
1131	WW02A00028	TORNILLO
1157	WW01A00456	TORNILLO #10