

Distribuidor Autorizado

SurteRápido.com

Venta de Refacciones
Electrodomesticas



MDP531RFR2 CONTROL PANEL

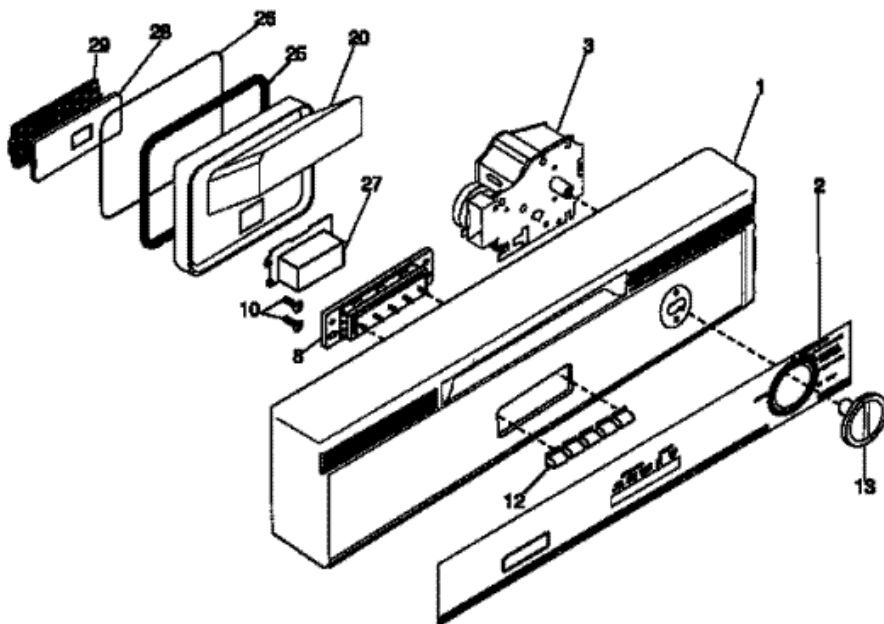



MDP531RFR2 CONTRO PANEL

1	154368103	PANEL-CONTROL, BLACK (S/P)
2	154235503	DESCONTINUADO
3	154301101	TIMER (S/P)
3	154095701	SCREW-TIMER, THREAD ROLLING, (S/P)
8	154222001	SWITCH-SELECTOR, 5 BUTTON (S/P)
10	5303318719	SCREW-SWITCH MTG, (2) (S/P)
12	154236501	PUSHBUTTON, BLACK (S/P)
13	154239301	KNOB-TIMER, BLACK (S/P)
20	154345101	VAPOR WELDMENT ASSY (S/P)
25	154287301	DESCONTINUADO
26	154240501	O-RING, VENT DR LINER (S/P)
27	154226701	ACTUATOR-WAX (S/P)
28	154226901	DESCONTINUADO
29	154226401	GASKET-VALVE (S/P)
*55161	154242201	SHIELD-SWITCH (S/P)
*55162	154296501	HARNESS-WIRING (S/P)
*55160	154131203	SHIELD-TIMER (S/P)

Distribuidor Autorizado

SurteRápido.com

Venta de Refacciones
Electrodomesticas

MDP531RFR2 DOOR

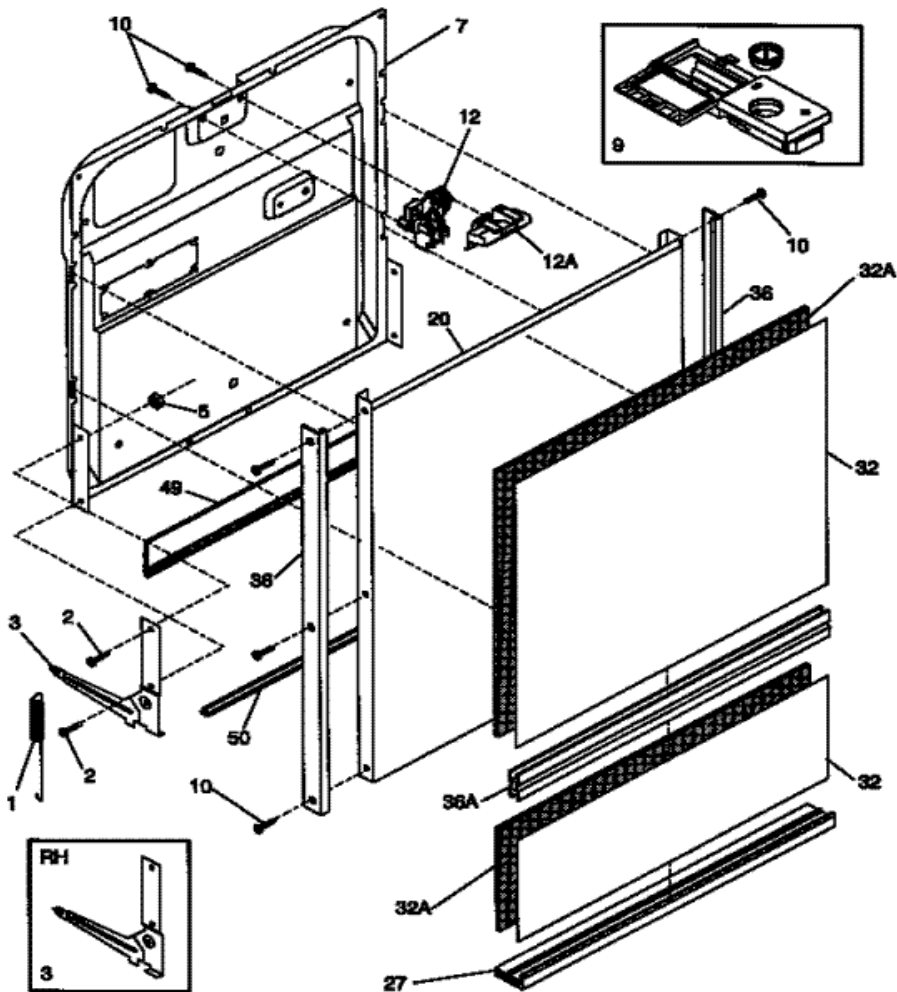



MDP531RFR2 DOOR

1	154430501	SPRING-DOOR, (2) (S/P)
2	154093301	SCREW-ARM ASSY (S/P)
3	5304409912	ARM ASSY, RH (S/P)
3	154298101	WASHER, ARM (NOT ILLUSTRATED) (S/P)
3	5304409913	ARM ASSY, LH (S/P)
3	154400601	PIN-ARM (NOT ILLUSTRATED) (S/P)
5	5303013272	NUT-ARM ASSY (S/P)
7	154228502	DOOR-INNER ASSY (S/P)
9	154574401	DISPENSER-DET/RINSE AID (S/P)
10	5300808658	SCREW, 8A X .375`` (S/P)
12	5304442175	LATCH ASSY (S/P)
12	154304301	SCREW-LATCH MTG, (2) (S/P)
12	5304442175	HANDLE-LATCH, BLACK (S/P)
20	154210601	MID DOOR ASSY (S/P)
27	154309504	TRIM-DOOR, CHROME, BOTTOM (S/P)
32	154229003	SPACER-INSERT, DOOR (S/P)
32	154229114	INSERT-DOOR, BLK/WHT (S/P)
32	154229113	INSERT-ACCESS, BLK/WHT (S/P)
32	154229002	SPACER-INSERT, ACCESS (S/P)
36	154309404	DESCONTINUADO
36	154309304	TRIM-DOOR, SIDE (S/P)
49	15476501	GASKET-DOOR, BOTTOM (S/P)
50	154211401	SUPPORT-DOOR HINGE (S/P)
*55165	154200601	SCREW-10-16 X 3/8 (S/P)
*55164	154026501	SCREW-8-18 X 5/8 (S/P)
*55163	154103702	SCREW-SWITCH MTG, (2) (S/P)

Distribuidor Autorizado

SurteRápido.com

Venta de Refacciones
Electrodomesticas

MDP531RFR2 TUB

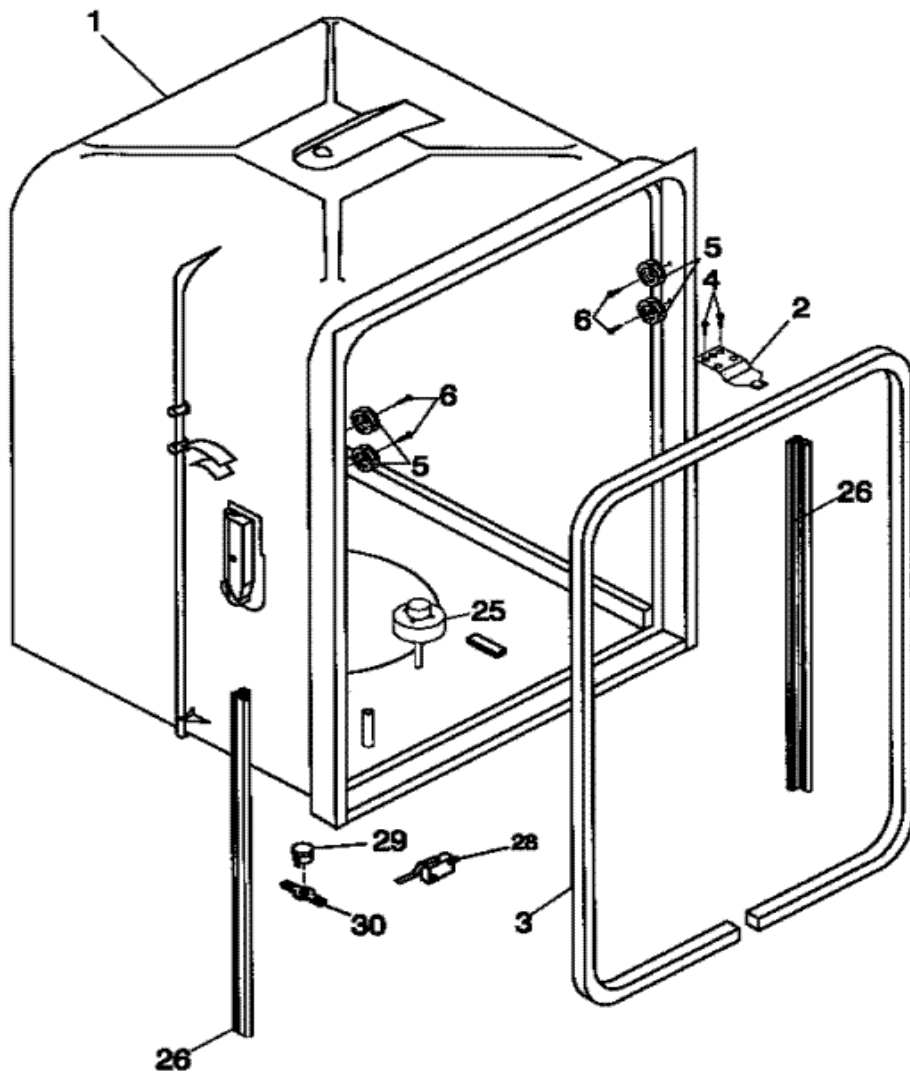



MDP531RFR2 TUB

1	154209301	TUB ASSY, W/FRAME PARTS (S/P)
2	154211601	STRIKE-DOOR (S/P)
3	154782401	GASKET-TUB (S/P)
4	154041001	SCREW, PLASK 1, 10-10 X 9/16 (S/P)
5	154080001	ROLLER-TUB (S/P)
6	154213401	SCREW, W/WASHER, (8) (S/P)
25	154209701	FLOAT (S/P)
26	154242301	TRIM-TUB FLANGE, (2) (S/P)
28	154408701	BRACKET-FLOAT SWITCH (S/P)
28	154225501	SWITCH-FLOAT (S/P)
29	154290204	THERMOSTAT, HIGH LIMIT (S/P)
30	154241101	RETAINER-THERMOSTAT (S/P)
30	154297701	SCREW, RETAINER-THERMO (S/P)
*55169	5300807813	CLAMP-TUBING, (2)
*55166	154200601	SCREW-10-16 X 3/8 (S/P)
*55167	154447102	INSULATION, TUB (S/P)
*55168	154239801	TUBING-WATER INLET (S/P)

Distribuidor Autorizado

SurteRápido.com

Venta de Refacciones
Electrodomesticas

MDP531RFR2 MOTOR & PUMP

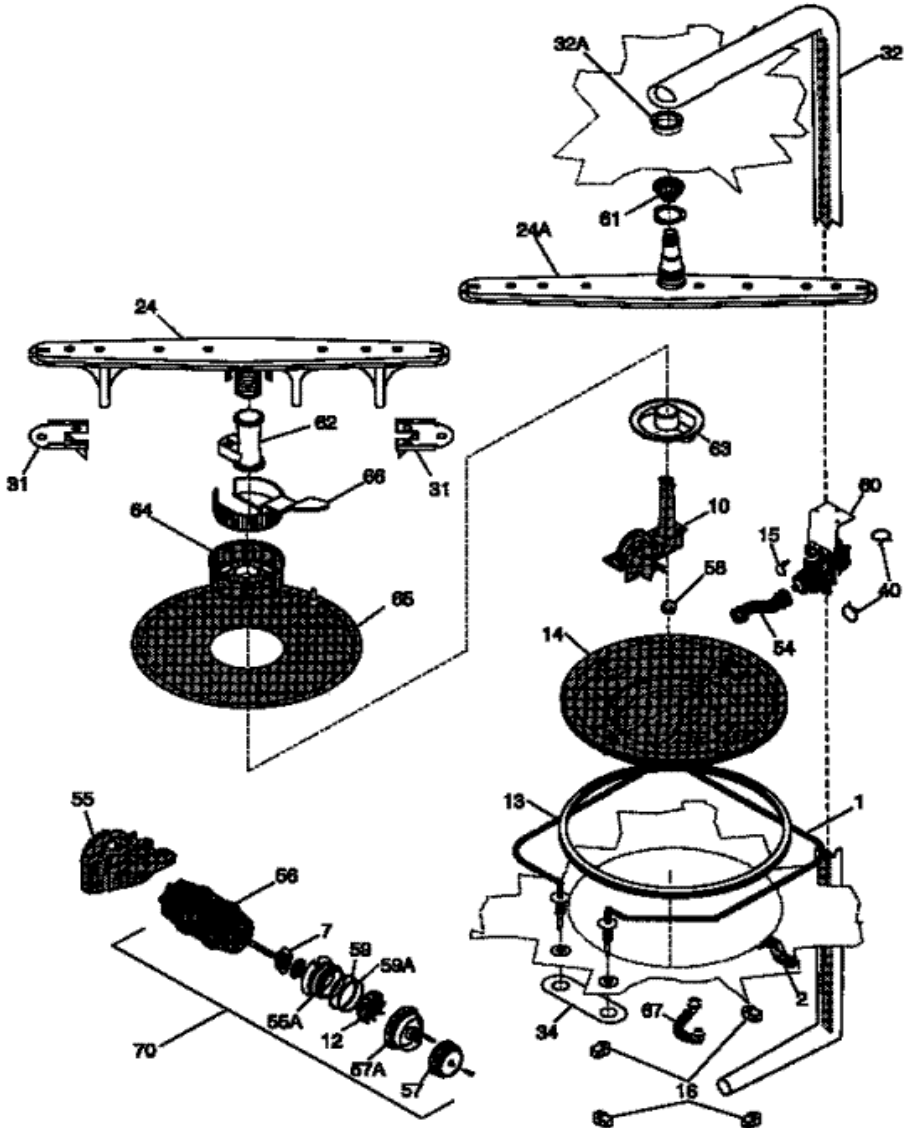



MDP531RFR2 MOTOR & PUMP

1	154106202	NUT-HEATER, (2) (NOT ILLUSTRATED) (S/P)
1	154665201	HEATER (S/P)
1	154289801	SHIELD-HEATER TERMINAL (S/P)
2	154211001	BRACKET-HEATER (S/P)
7	154245901	MACERATOR (S/P)
10	154245501	COVER-VOLUTE (S/P)
12	154245801	IMPELLER (S/P)
12	154282701	SCREW, SS IMPELLER (NOT ILLUSTRATED) (S/P)
13	154246801	GASKET-SUMP (S/P)
14	154365902	HOUSING-SUMP (S/P)
15	154246701	CHECK VALVE (S/P)
16	154246501	RETAINER, SUMP (S/P)
24	154252001	NUT-SPRAY ARM (NOT ILLUSTRATED) (S/P)
24	154313601	SPRAY ARM-CENTER (S/P)
24	154414101	SPRAY ARM-LOWER, W/COVER (S/P)
31	154281001	SHIELD-SPRAY ARM, (2) (S/P)
32	154412101	TUBE-DELIVERY (S/P)
34	154064901	WASHER-INSULATING
40	154611101	CLAMP-HOSE (S/P)
54	154234401	HOSE-CONNECTOR (S/P)
55	154246201	BRACKET-MOTOR, FRONT (S/P)
55	154325701	BRACKET-MOTOR (S/P)
56	154473001	MOTOR, CIRCULATION (S/P)
56	154287201	SCREW, MOTOR MOUNTING (S/P)
57	154246101	BARREL, REAR (S/P)
57	154246001	BARREL, FRONT (S/P)
58	154246402	CHECK BALL (S/P)
59	154246901	O-RING, REAR (S/P)
59	154247001	O-RING, FRONT (S/P)
60	154247501	DRAIN-PUMP ASSY (S/P)
60	154247502	BRACKET-MOTOR, DRAIN (S/P)
61	154426201	NOZZLE, 3RD LEVEL, SPRAY ARM (S/P)
62	154412101	SUPPORT-SPRAY ARM (S/P)

63	154252201	BASE-SOIL DIRECTOR (S/P)
64	154252301	FILTER-SOIL DIRECTOR (S/P)
65	154252401	FILTER-POLYPRO (S/P)
66	154252701	TRAP-GLASS (S/P)
67	154246601	DESCONTINUADO
70	154473001	MOTOR & PUMP ASSY, (S/P)
*55173	5300807813	CLAMP, DRAIN SIDE
*55174	131306215	CLAMP, INTAKE (S/P)
*55172	154241101	RETAINER-THERMOSTAT (S/P)
*55170	154227806	THERMOSTAT-TEMP BOOST (S/P)
*55171	5303283073	CLAMP, DRAIN PUMP (S/P)
*55175	154247401	CLAMP, CONNECTOR PUMP (S/P)
*55176	5303316032	SCREW, TRUSS SS, 8 .625 (S/P)

Distribuidor Autorizado

SurteRápido.com

Venta de Refacciones
Electrodomesticas

MDP531RFR2 FRAME

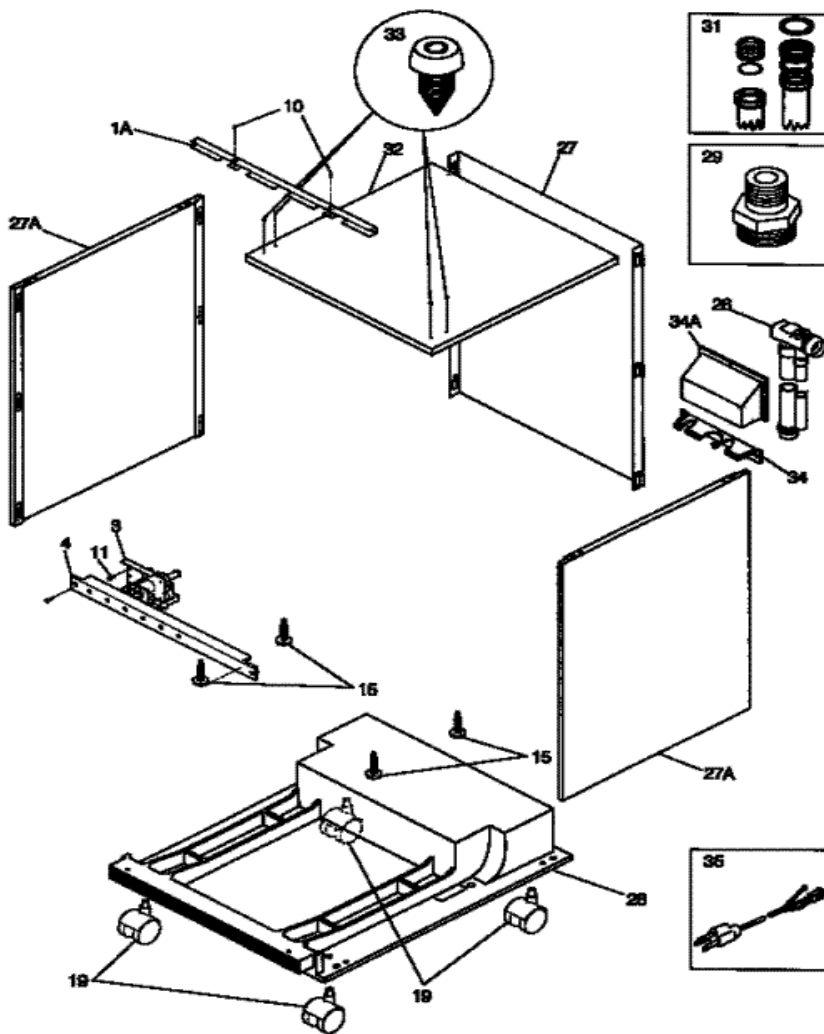



MDP531RFR2 FRAME

1	154236101	BRACKET-FRONT FRAME (S/P)
3	154637401	VALVE-WATER (S/P)
4	154208701	BRACE-FRONT (S/P)
10	5300808658	SCREW, 8A X .375` (S/P)
11	154200701	SCREW-10-32 X 3/8 (S/P)
15	154210901	SCREW-LEVELING (S/P)
19	154280201	CASTER, 30 (S/P)
26	154187105	HOSE & COUPLER ASSY (S/P)
27	154229601	WRAPPER, BACK (S/P)
27	154229701	PANEL, SIDE, LH (S/P)
27	154229702	PANEL, SIDE, RH (S/P)
28	154282801	BASE AND WEIGHT ASSY (S/P)
29	154242501	ADAPTER-WATER VALVE (S/P)
31	5303304813	FAUCET ADAPTER ASSY (S/P)
32	154241802	TOP, GRAY (S/P)
33	154241701	SCREW, TOP (S/P)
34	154249801	POCKET, UPPER (S/P)
34	5304469949	POCKET, LOWER (S/P)
35	154253001	CORD-ELECTRIC (S/P)
*55181	154280802	COVER-ACCESS (S/P)
*55180	154242801	SCREW, PHILLIPS, 8-18 X 7/16 (S/P)
*55177	154025901	SCREW, TRUSS HEAD, 10 X 0.625 (S/P)
*55178	154041001	SCREW, PLASK 1, 10-10 X 9/16 (S/P)
*55185	5300807373	WASHER (S/P)
*55183	5300804426	CLAMP, HOSE & COUPLER (S/P)
*55184	5300807270	SCREW (S/P)
*55179	154200601	SCREW-10-16 X 3/8 (S/P)
*55182	154287101	CLIP, COVER ACCESS (S/P)

Distribuidor Autorizado

SurteRápido.com

Venta de Refacciones
Electrodomesticas

MDP531RFR2 RACKS

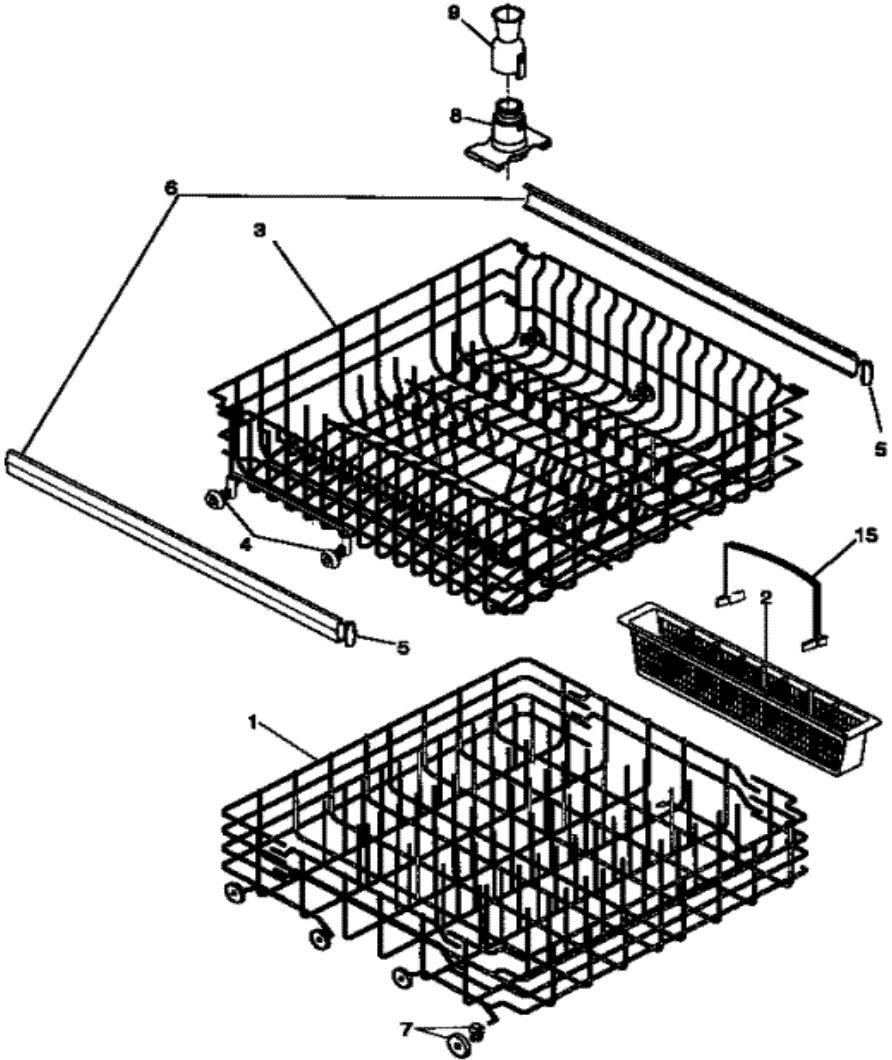



MDP531RFR2 RACKS

1	154207803	RACK ASSY-LOWER (S/P)
2	5303282018	BASKET-SILVERWARE (S/P)
3	154321104	RACK ASSY-UPPER (S/P)
4	5300809974	WHEEL & BRACKET ASSY, UPPER RACK (S/P)
5	5300809927	CAP-SLIDE, (4) (S/P)
6	154597801	SLIDE-RACK, (2) (S/P)
7	154174501	WHEEL & BRACKET ASSY, LOWER RACK (S/P)
8	154251901	BASE-FUNNEL (S/P)
9	154251801	FUNNEL (S/P)
15	154254402	DESCONTINUADO