

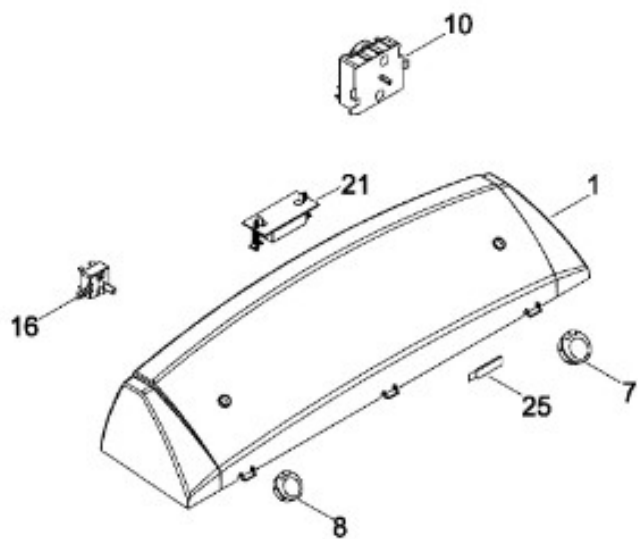

SECADORA MKRR13FWAWB00

SISTEMA CONTROLES / CONTROL SYSTEM

MKRR13FWAWB00





SECADORA MKRR13FWAWB00

PUERTA (ENS) / DOOR (ASM)

MKRR13FWAWB00

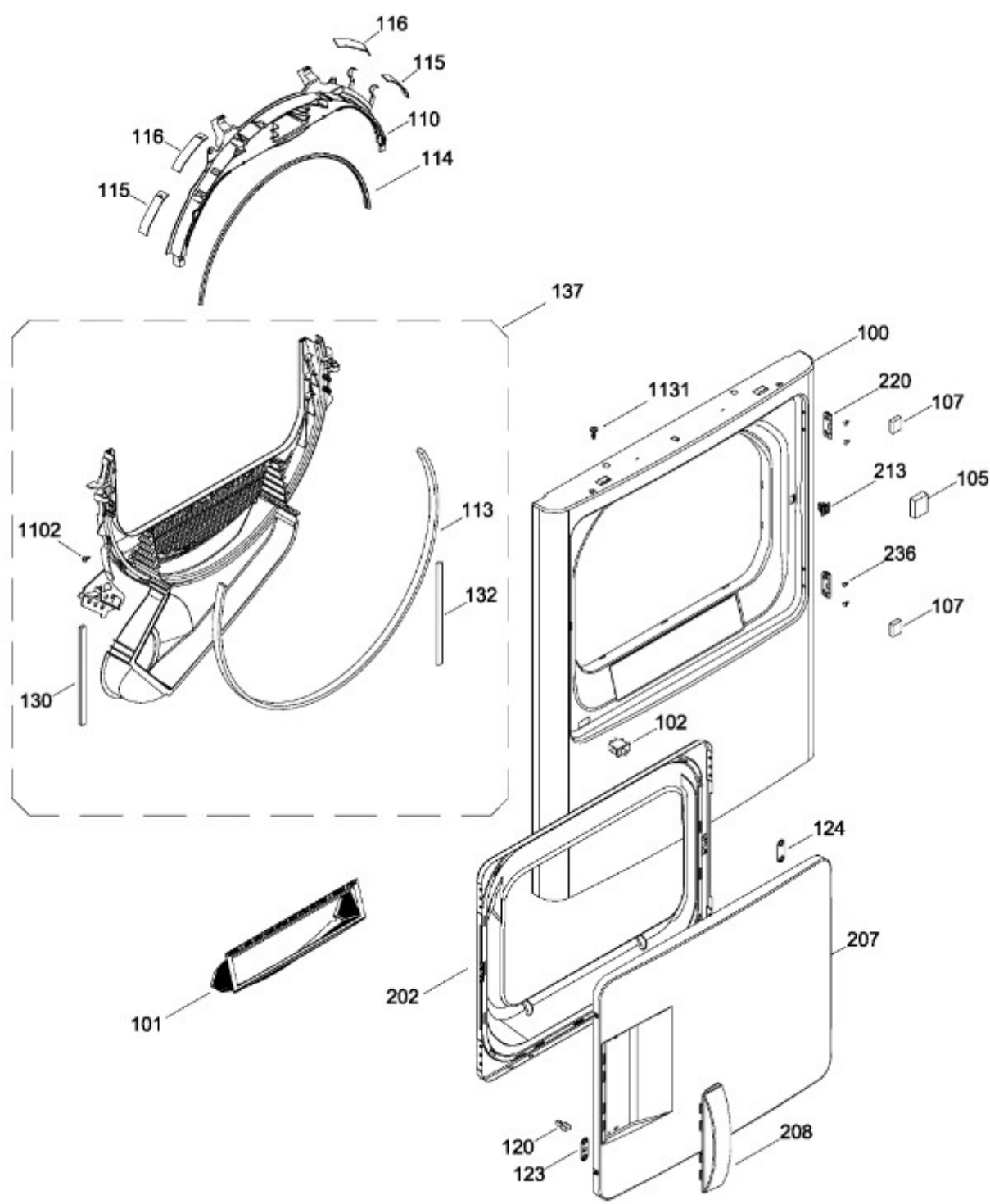

BENITO JUÁREZ #1500 GPE ZITON, CD. GUADALUPE NUEVO LEÓN TEL: 8183377999 Y 49
 HORARIOS: LUNES A VIERNES 8:30 A 6:00 PM Y SÁBADOS DE 8:30 A 2:00 PM
 WEB: www.denek.com



SECADORA MKRR13FWAWB00

GABINETE / STRUCTURE

MKRR13FWAWB00

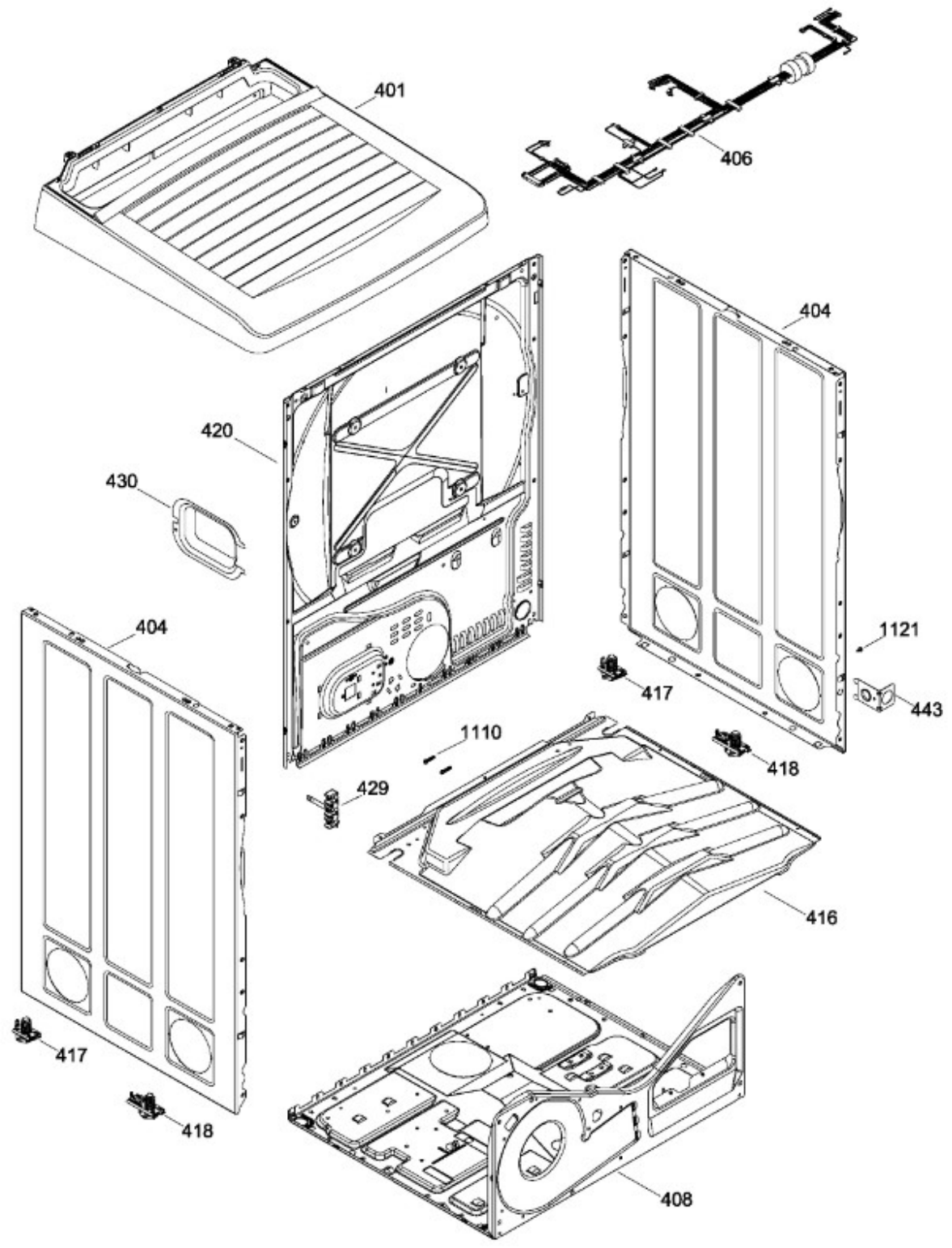

BENITO JUÁREZ #1500 GPE ZITON, CD. GUADALUPE NUEVO LEÓN TEL: 8183377999 Y 49
HORARIOS: LUNES A VIERNES 8:30 A 6:00 PM Y SÁBADOS DE 8:30 A 2:00 PM
WEB: www.denek.com



SECADORA MKRR13FWAWB00

SISTEMA DE TRANSMISION / BLOWER & DRIVE ASSEMBLY

MKRR13FWAWB00

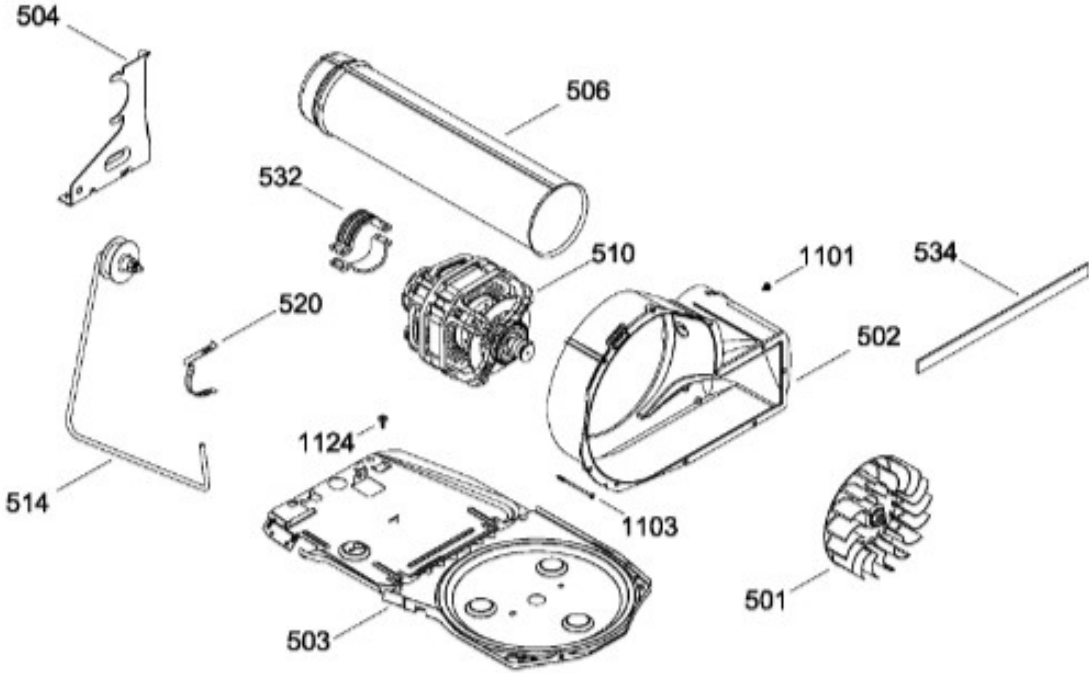

BENITO JUÁREZ #1500 GPE ZITON, CD. GUADALUPE NUEVO LEÓN TEL: 8183377999 Y 49
HORARIOS: LUNES A VIERNES 8:30 A 6:00 PM Y SÁBADOS DE 8:30 A 2:00 PM
WEB: www.denek.com



SECADORA MKRR13FWAWB00

TAMBOR / DRUM

MKRR13FWAWB00

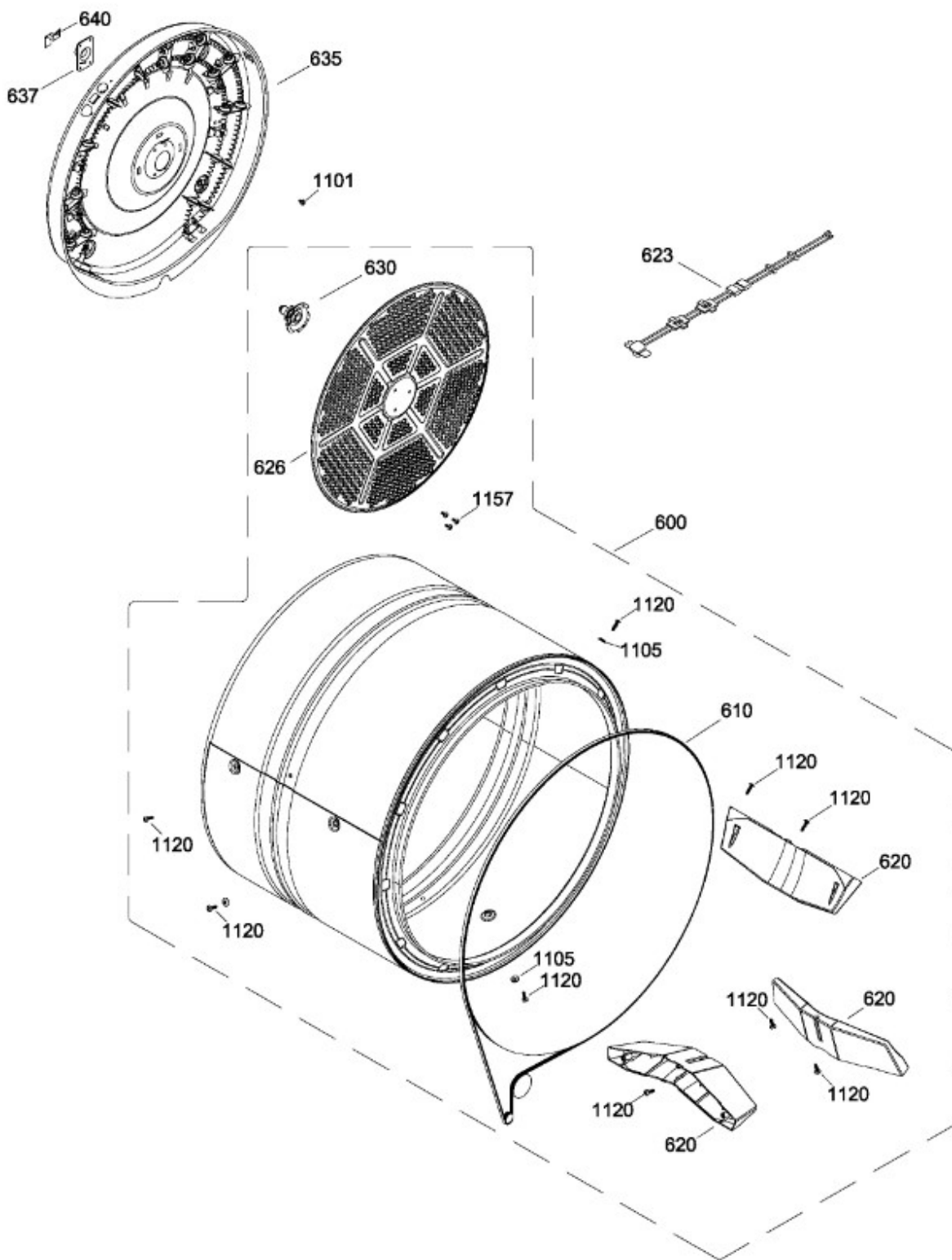

BENITO JUÁREZ #1500 GPE ZITON, CD. GUADALUPE NUEVO LEÓN TEL: 8183377999 Y 49
 HORARIOS: LUNES A VIERNES 8:30 A 6:00 PM Y SÁBADOS DE 8:30 A 2:00 PM
 WEB: www.denek.com

Guía	Refacción	Descripción
1	WW03L00233	COPETE Y GRAFICOS ENS
7	WW02F00227	PERILLA CONTROL
8	WW02L00132	PERILLA ROTATORIA ENSAMBLE
10	WW02F00070	RELOJ
10	WW02F00070	RELOJ
16	WW02L00083	INTERRUPTOR DE INICIO
21	WW02F00089	RESISTENCIA ENS.
21	WW02A00302	RESISTENCIA ENS.
25	WW03A00089	ANCLA PLACA
100	WW02L00049	PANEL FRONTAL
101	WW02F00190	FILTRO ATRAPAPELUSA
101	WW02F00615	FILTRO ATRAPAPELUSA
102	WW02L00025	INTERRUPTOR PUERTA
105	WW02L00210	SEPARADOR PUERTA
107	WW03L00062	ESPACIADOR PUERTA
110	WW02L00199	COJINETE SUP.
110	WW01L01430	COJINETE SUP.
113	WW02L00138	FELPA DUCTO RECOLECTOR
114	WW02L00145	SELLO PUERTA
115	WW02A00033	BEARING_SLIDE
116	WW02L00038	BEARING_SLIDE
120	WW02A00004	STRIKE
123	WW02A00056	STRIKE PLATE
124	WW02A00057	STRIKE PLATE
130	WW02L00042	SELLO
132	WW02L00039	SELLO
132	WW03F00354	SELLO
137	WW02F00248	DUCTO TRAMPA ENS (SIN SENSORES)
137	WW02F00598	DUCTO TRAMPA ENS (SIN SENSORES)
202	WW02L00053	INNER DOOR
207	WW02L00051	PUERTA EXTERIOR
207	WW02L00051	PUERTA EXTERIOR
207	WW02L00051	PUERTA EXTERIOR
208	WW02L00016	JALADERA PUERTA(BCO)
213	WW02L00037	LATCH ASM.

Guía	Refacción	Descripción
220	WW02L00029	BISAGRA
220	WW02L00028	BISAGRA
236	WW02A00065	BOTON BELLEZA
401	WW03L00094	CUBIERTA
404	WW02L00149	PANEL LATERAL
404	WW02L00149	PANEL LATERAL
404	WW02L00149	PANEL LATERAL
406	WW02F00247	ARNES ENSAMBLE ELECTRICO
408	WW02F00076	BASTIDOR BASE
416	WW02A00045	DEFLECTOR
416	WW02A00045	DEFLECTOR
416	WW02A00045	DEFLECTOR DE CALOR
417	WW02A00059	ENS. SOPORTE POST.
418	WW02L00108	ENS. SOPORTE FRONT.
420	WW02F00263	PANEL POSTERIOR
429	WW02F00172	TERMINAL BLOCK
430	WW03L00096	CUBIERTA BLOQUE TERMINALES
430	WW02L00246	CUBIERTA BLOQUE TERMINALES
443	WW02A00119	SOPORTE ANTI TENSION
501	WW02A00011	SOPLADOR PUERTA
501	WW01F01162	SOPLADOR PUERTA
502	WW02A00012	CARCAZA ASPAS
502	WW02L00013	CARCAZA ASPAS
502	WW02L00433	CAJA DEL VENTILADOR
503	WW01L01163	BASE MOTOR
503	WW01L01163	BASE MOTOR
503	WW01L01163	BASE MOTOR
503	WW02L00642	BASE MOTOR
504	WW02F00027	SOPORTE MOTOR
506	572D559P006	CONDUCTO DE ESCAPE
510	WW01F00903	MOTOR Y POLEA ENS
514	WW02A00008	ENS. BRAZO AUXILIAR
514	WW03F00350	ENS. BRAZO AUXILIAR
520	WW02F00031	CLIP MOTOR
532	WW02F00003	CORREA MOTOR

Guía	Refacción	Descripción
532	WW02A00232	CORREA MOTOR
534	WW02A00026	EMPAQUE ESCAPE SOPLADOR
534	WW02F00785	EMPAQUE ESCAPE SOPLADOR
600	WW02F00056	ENS. TAMBOR
610	WW02F00028	BANDA SECADORA
610	WW02F00854	BANDA SECADORA
620	WW02L00143	BAFFLE
623	WW02F00050	ARNES
626	WW02F00030	DIFUSOR
630	WW02A00019	SOPORTE Y FLECHA ENSAMBLE
635	WW02A00050	ENS. CALENTADOR
635	WW02A00050	ENS. CALENTADOR
635	WW02A00050	CALENTADOR ENSAMBLE
635	WW02A00050	ENS. CALENTADOR
637	WW02A00005	RETENEDOR RODAMIENTO
640	WW01A00443	GROUND STRAP ASSEMBLY
1101	WW02A00030	TORNILLO
1101	WW02A00211	TORNILLO
1102	WW02A00029	TORNILLO
1102	WW02A00211	TORNILLO
1103	WW02A00032	TORNILLO
1105	WW02A00002	ARANDELA
1110	WW02A00121	TORNILLO
1120	WW02A00031	TORNILLO
1121	WW01A00001	TORNILLO
1124	WW02A00070	TORNILLO
1131	WW02A00028	TORNILLO
1157	WW01A00456	TORNILLO #10