

Refrigerador Maytag MTF2191ARW

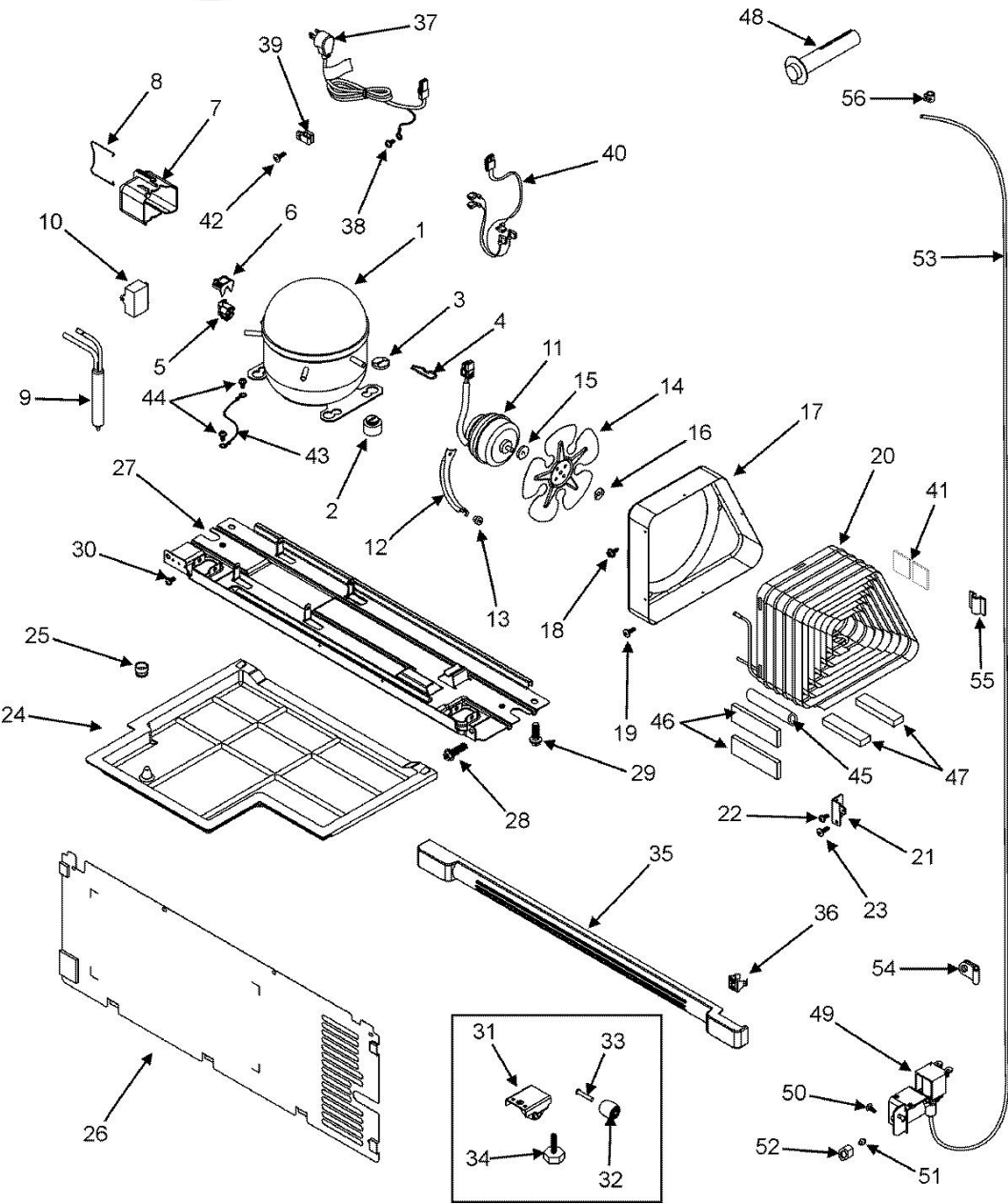



Refrigerador Maytag MTF2191ARW

Guía	N.P.	Serie	Descripción
1	W10309989	Series 50	KIT, COMPRESSOR
2	63001006	Series 50	GROMMET, COMPRESSOR
3	63001007	Series 50	WASHER, COMPRESSOR
4	63001008	Series 50	SPRING, COMPRESSOR
5	63001003	Series 50	RELAY, PTC
6	63001004	Series 50	OVERLOAD
7	63001013	Series 50	COVER, RELAY
8	63001014	Series 50	CLIP, RELAY COVER
9	13900-1	Series 50	DRIER
10	63001005	Series 50	CAPACITOR, RUN
11	63001575	Series 50	MOTOR, CONDENSER FAN
12	63001020	Series 50	BRACKET, FAN MOTOR
12	63001092	Series 50	SCREW
13	63001017	Series 50	GROMMET, BRACKET
14	63001018	Series 50	BLADE, CONDENSER FAN
15	63001576	Series 50	GROMMET, FAN MOTOR
16	63001577	Series 50	CLIP, FAN BLADE
17	63001015	Series 50	SHROUD, CONDENSER
18	63001094	Series 50	SCREW
19	63001093	Series 50	SCREW
20	63001778	Series 50	CONDENSER
21	63001023	Series 50	BRACKET, VALVE
24	63001573	Series 50	PAN, DRAIN
25	63001022	Series 50	CAP, DRAIN
26	63001099	Series 50	SCREW
26	63001574	Series 50	COVER, MACHINE COMPARTMENT
27	Y00000000	Series 50	SEE NOTE (BASE PAN NOT AVAILABLE)



Refrigerador Maytag MTF2191ARW

Guía	N.P.	Serie	Descripción
28	63001251	Series 50	BOLT
29	63001252	Series 50	BOLT
31	56001210	Series 50	SCREW
31	63001100	Series 50	WHEEL ASSY. (FRT)
32	63001001	Series 50	WHEEL (REAR)
33	63001002	Series 50	PIN, WHEEL
34	63001025	Series 50	LEG, LEVELING
35	63001578	Series 50	KICKPLATE ASSY. (WHT)
36	63001351	Series 50	CLIP, KICKPLATE
37	63001570	Series 50	CORD, POWER
38	63001571	Series 50	SCREW
39	63001346	Series 50	CLIP, POWER CORD
40	63001012	Series 50	WIRE HARNESS, COMPRESSOR
41	63001427	Series 50	SEAL
43	63001011	Series 50	WIRE, GROUND
44	63001091	Series 50	SCREW
45	63001424	Series 50	SEAL
46	63001425	Series 50	SEAL
47	63001426	Series 50	SEAL
48	61005940	Series 50	GROMMET, FILL TUBE
49	61005273	Series 50	VALVE, WATER
50	61002819	Series 50	SCREW
51	69431-1	Series 50	SLEEVE, BRASS
52	69432-1	Series 50	NUT, BRASS (1/4``)
53	67579-26	Series 50	TUBING
54	53516-8	Series 50	CLAMP, TUBING
55	61004913	Series 50	CLIP, WATER LINE (ADHESIVE)
56	60333-4	Series 50	CLAMP, SPRING

Refrigerador Maytag MTF2191ARW

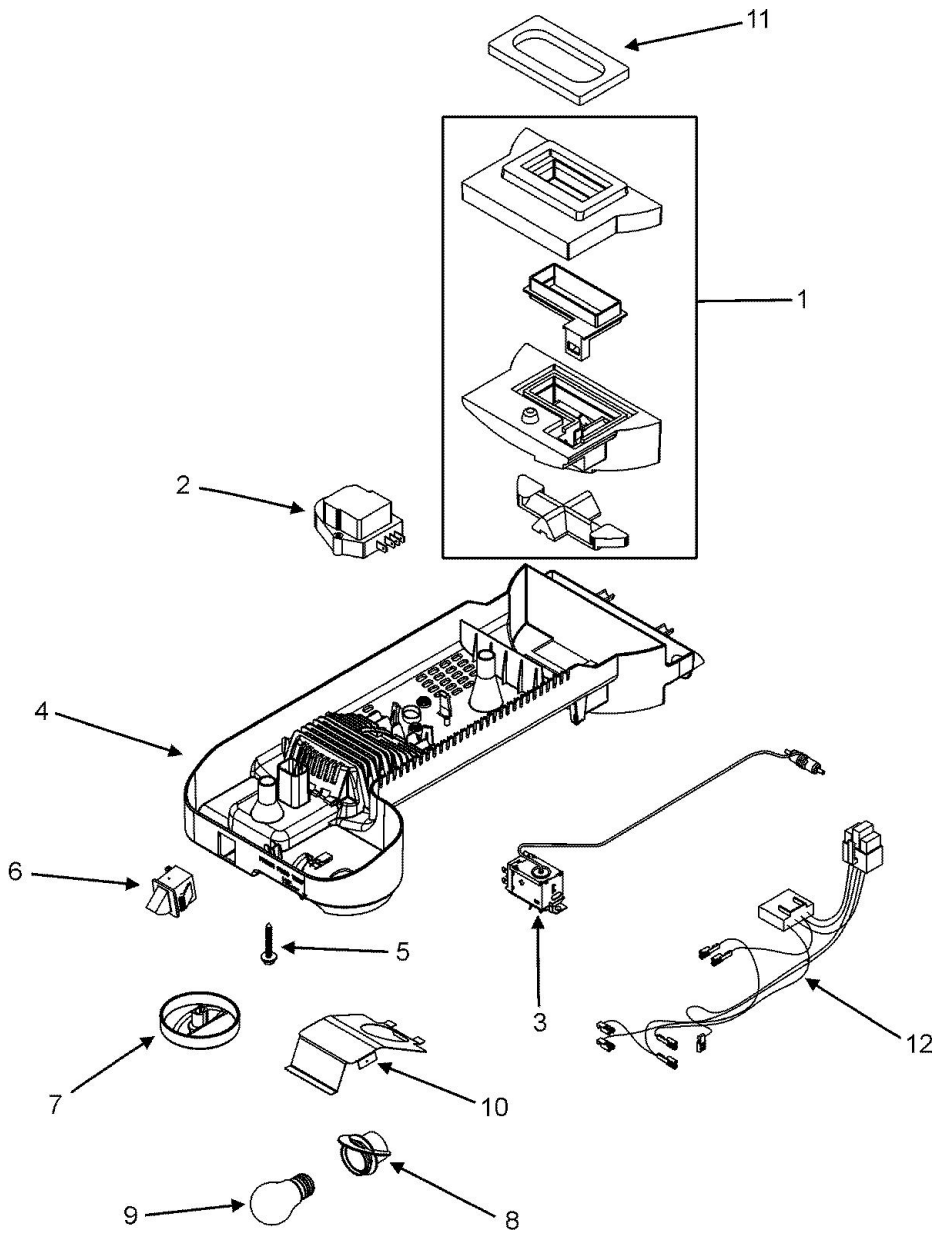



Refrigerador Maytag MTF2191ARW

Guía	N.P.	Serie	Descripción
1	63001352	Series 50	DAMPER/INSULATION ASSY.
2	405007-1	Series 50	SCREW
2	63001580	Series 50	TIMER, DEFROST
3	63001358	Series 50	CONTROL ASSY., TEMPERATURE
3	65275-81	Series 50	SCREW
4	63001354	Series 50	HOUSING, CONTROL
5	63001036	Series 50	SCREW
6	63001030	Series 50	SWITCH, LIGHT
7	63001355	Series 50	KNOB, TEMPERATURE CONTROL
8	63001356	Series 50	RECEPTACLE, BULB
9	63001035	Series 50	BULB, LIGHT
10	63001357	Series 50	PLATE, BULB
11	63001582	Series 50	SEAL, DAMPER ASSY.
12	63001581	Series 50	WIRE HARNESS, CONTROLS

Refrigerador Maytag MTF2191ARW

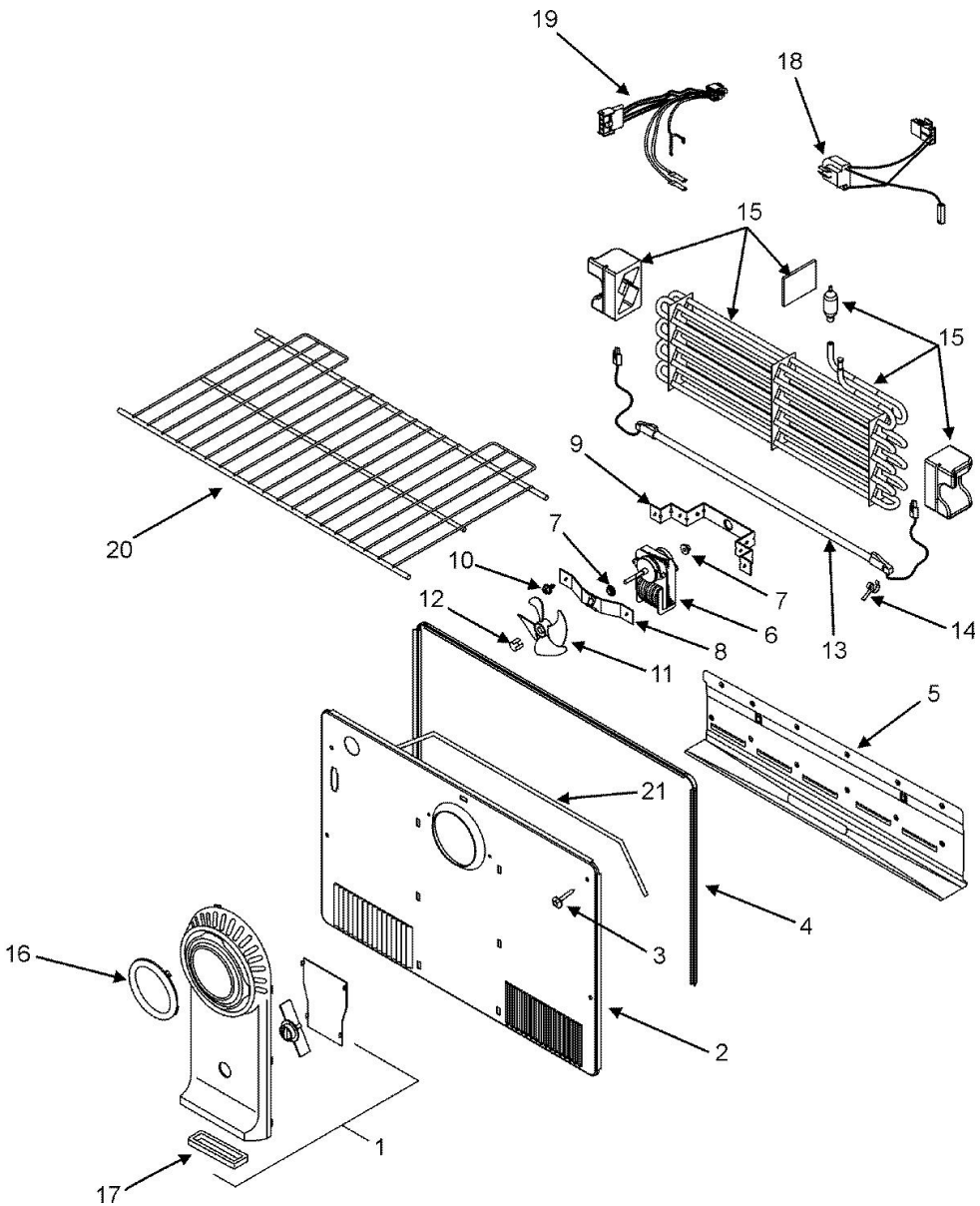



Refrigerador Maytag MTF2191ARW

Guía	N.P.	Serie	Descripción
1	63001382	Series 50	TUNNEL ASSY., AIR
2	63001591	Series 50	COVER, EVAPORATOR
3	63001036	Series 50	SCREW
4	63001593	Series 50	GASKET, EVAPORATOR COVER
5	63001594	Series 50	TRAY, DRIP
6	63001057	Series 50	MOTOR, EVAPORATOR FAN
7	63001058	Series 50	BUSHING, EVAPORATOR FAN
8	63001062	Series 50	RETAINER, EVAPORATOR FAN
9	63001063	Series 50	BRACKET, EVAPORATOR FAN
10	63001104	Series 50	SCREW
11	63001060	Series 50	BLADE, EVAPORATOR FAN
12	63001061	Series 50	CLIP, FAN BLADE
13	63001595	Series 50	HEATER, DEFROST
14	63001050	Series 50	CLIP, DEFROST HEATER
15	12002614	Series 50	KIT, EVAPORATOR
16	63001428	Series 50	COVER, FAN
17	63001429	Series 50	SEAL
18	63001599	Series 50	THERMOSTAT, DEFROST (3 WIRE)
19	63001600	Series 50	WIRE HARNESS, FRZ.
20	63001601	Series 50	SHELF, FRZ.
21	63001592	Series 50	SEAL, EVAPORATOR COVER

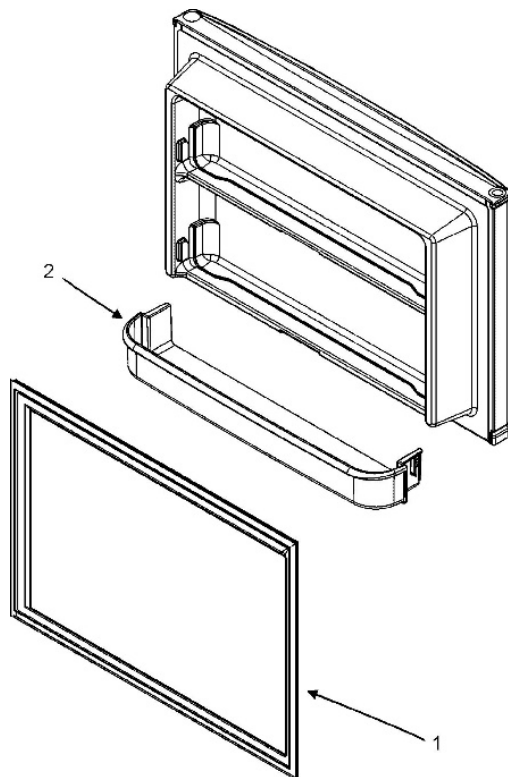

Guía	N.P.	Serie	Descripción
1	63001612	Series 50	SEAL, FRZ. DOOR (WHT)
2	63001613	Series 50	SHELF, PICK OFF

Refrigerador Maytag MTF2191ARW

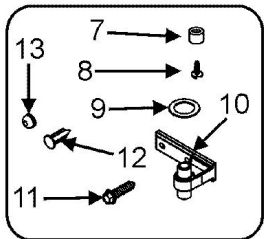
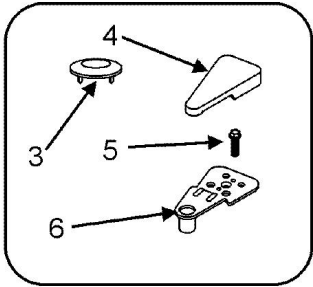
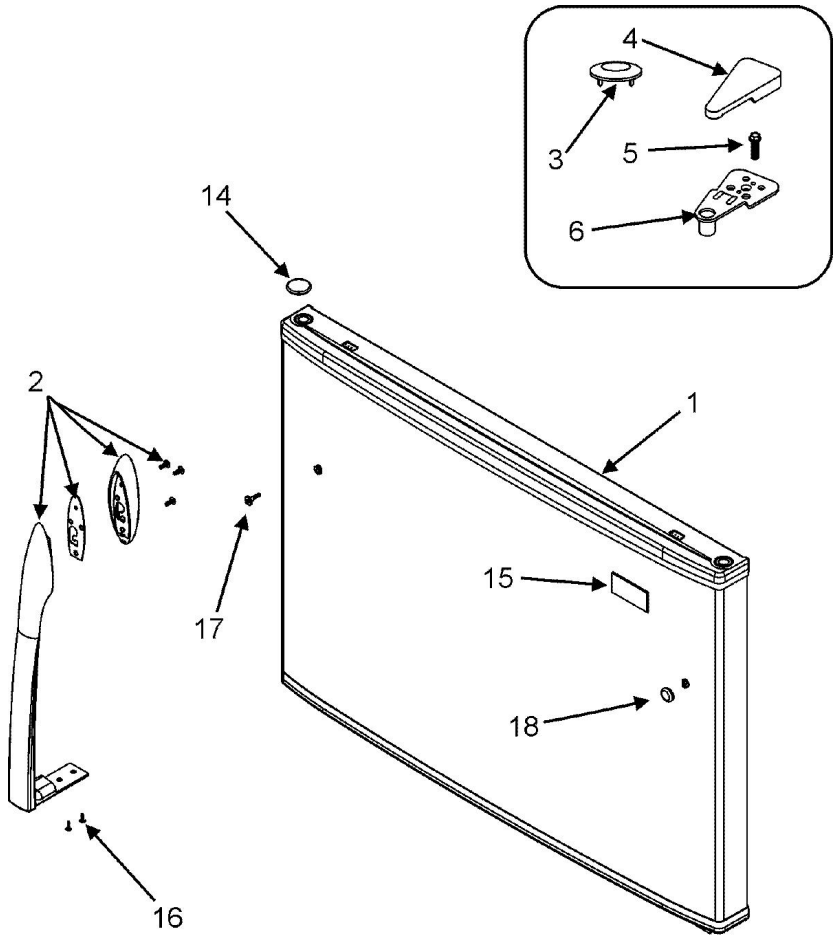



Refrigerador Maytag MTF2191ARW

Guía	N.P.	Serie	Descripción
1	63001610	Series 50	DOOR ASSY., FREEZER (WHT)
2	63001436	Series 50	HANDLE ASSY., DOOR (WHT)
3	63001110	Series 50	CAP, HINGE (WHT)
4	63001406	Series 50	COVER, UPPER HINGE (WHT)
5	63001231	Series 50	SCREW
6	63001408	Series 50	HINGE, UPPER
7	63001409	Series 50	STOP, DOOR (WHT)
8	63001572	Series 50	SCREW
9	63001079	Series 50	WASHER, HINGE
10	63001411	Series 50	HINGE, CENTER (WHT)
11	63001234	Series 50	SCREW
12	63001413	Series 50	CAP, CENTER HINGE (WHT)
13	63001115	Series 50	CAP, HINGE (WHT)
14	63001107	Series 50	CAP, BUSHING (WHT)
15	63001459	Series 50	NAMEPLATE (MAYTAG)
16	63001432	Series 50	SCREW
17	63001435	Series 50	SCREW
18	63001433	Series 50	CAP, HANDLE SCREW (WHT)

Refrigerador Maytag MTF2191ARW

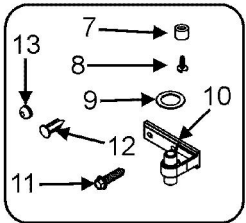
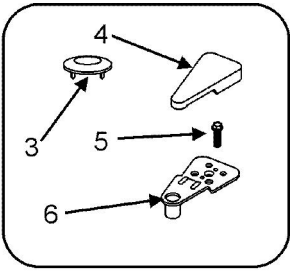
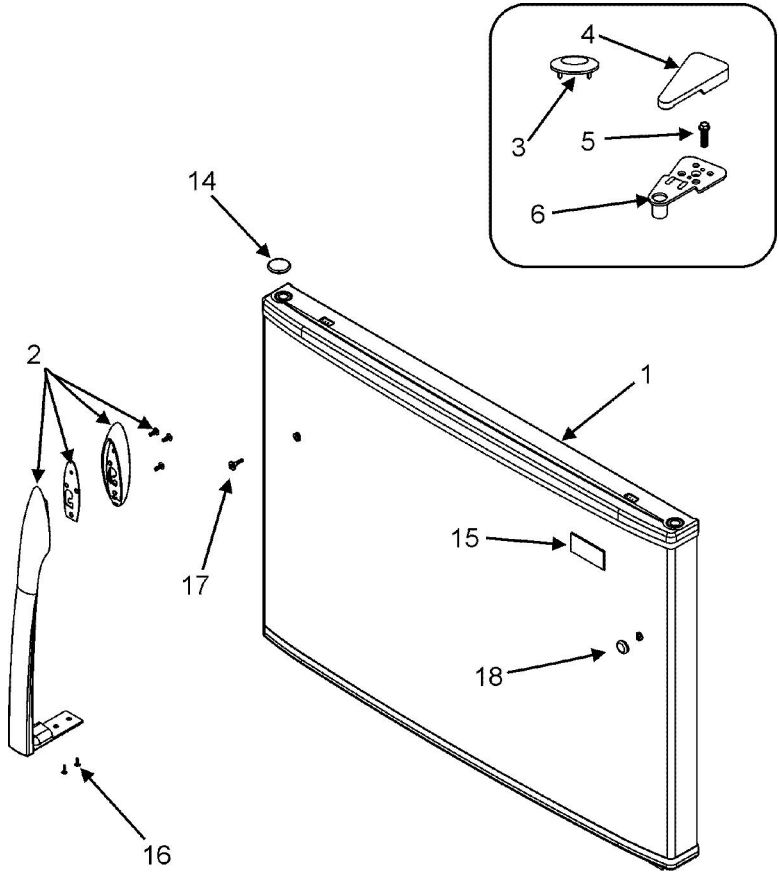



Refrigerador Maytag MTF2191ARW

Guía	N.P.	Serie	Descripción
1	63001610	Series 50	DOOR ASSY., FREEZER (WHT)
2	63001436	Series 50	HANDLE ASSY., DOOR (WHT)
3	63001110	Series 50	CAP, HINGE (WHT)
4	63001406	Series 50	COVER, UPPER HINGE (WHT)
5	63001231	Series 50	SCREW
6	63001408	Series 50	HINGE, UPPER
7	63001409	Series 50	STOP, DOOR (WHT)
8	63001572	Series 50	SCREW
9	63001079	Series 50	WASHER, HINGE
10	63001411	Series 50	HINGE, CENTER (WHT)
11	63001234	Series 50	SCREW
12	63001413	Series 50	CAP, CENTER HINGE (WHT)
13	63001115	Series 50	CAP, HINGE (WHT)
14	63001107	Series 50	CAP, BUSHING (WHT)
15	63001459	Series 50	NAMEPLATE (MAYTAG)
16	63001432	Series 50	SCREW
17	63001435	Series 50	SCREW
18	63001433	Series 50	CAP, HANDLE SCREW (WHT)

Refrigerador Maytag MTF2191ARW

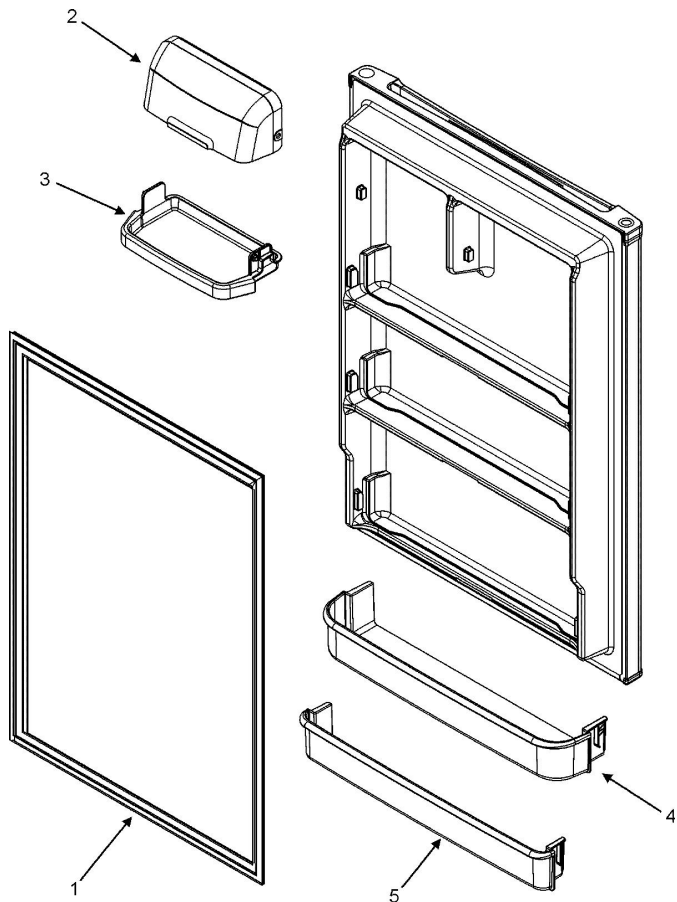

Guía	N.P.	Serie	Descripción
1	63001607	Series 50	SEAL, F.F. DOOR (WHT)
2	63001605	Series 50	DOOR, DAIRY
3	63001606	Series 50	SHELF, DAIRY
4	63001608	Series 50	SHELF, BOTTLE PICK OFF
5	63001609	Series 50	SHELF, PICK OFF

Refrigerador Maytag MTF2191ARW

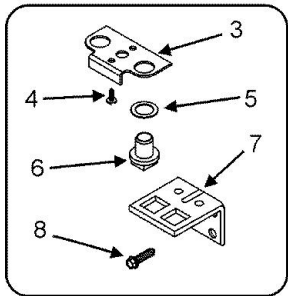
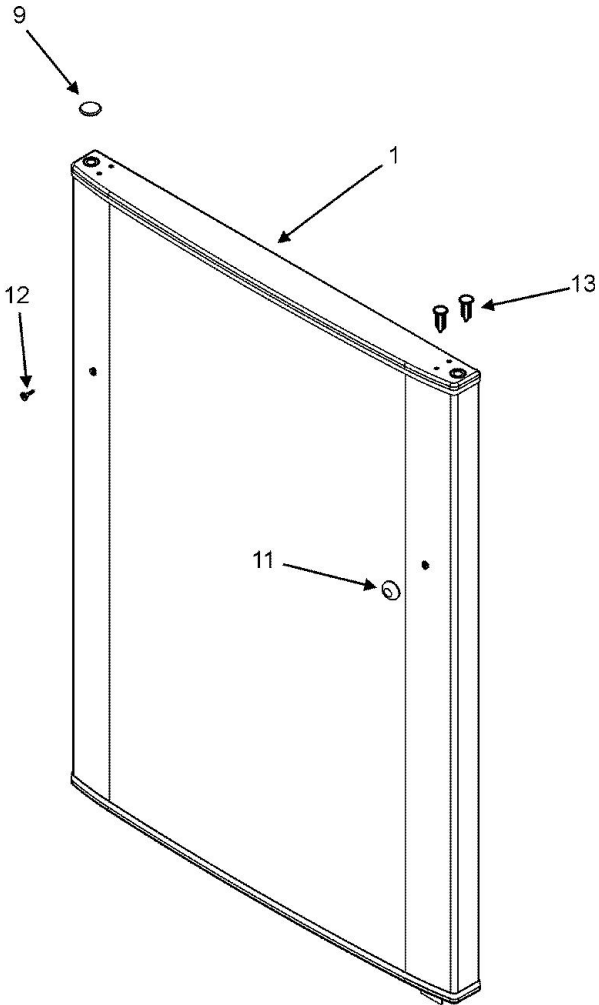
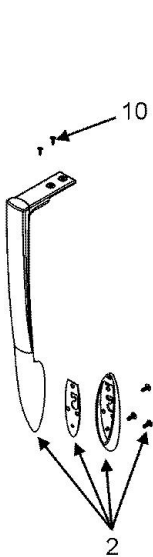



Refrigerador Maytag MTF2191ARW

Guía	N.P.	Serie	Descripción
1	63001602	Series 50	DOOR ASSY., FRESH FOOD (WHT)
2	63001430	Series 50	HANDLE ASSY., DOOR (WHT)
3	63001604	Series 50	STOP, DOOR
4	63001255	Series 50	SCREW
5	63001079	Series 50	WASHER, HINGE
6	63001089	Series 50	PIN, LOWER HINGE
7	63001128	Series 50	HINGE, LOWER !!
8	63001226	Series 50	SCREW
9	63001107	Series 50	CAP, BUSHING (WHT)
10	63001432	Series 50	SCREW
11	63001433	Series 50	CAP, HANDLE SCREW (WHT)
12	63001435	Series 50	SCREW
13	63001413	Series 50	CAP, CENTER HINGE (WHT)

Refrigerador Maytag MTF2191ARW

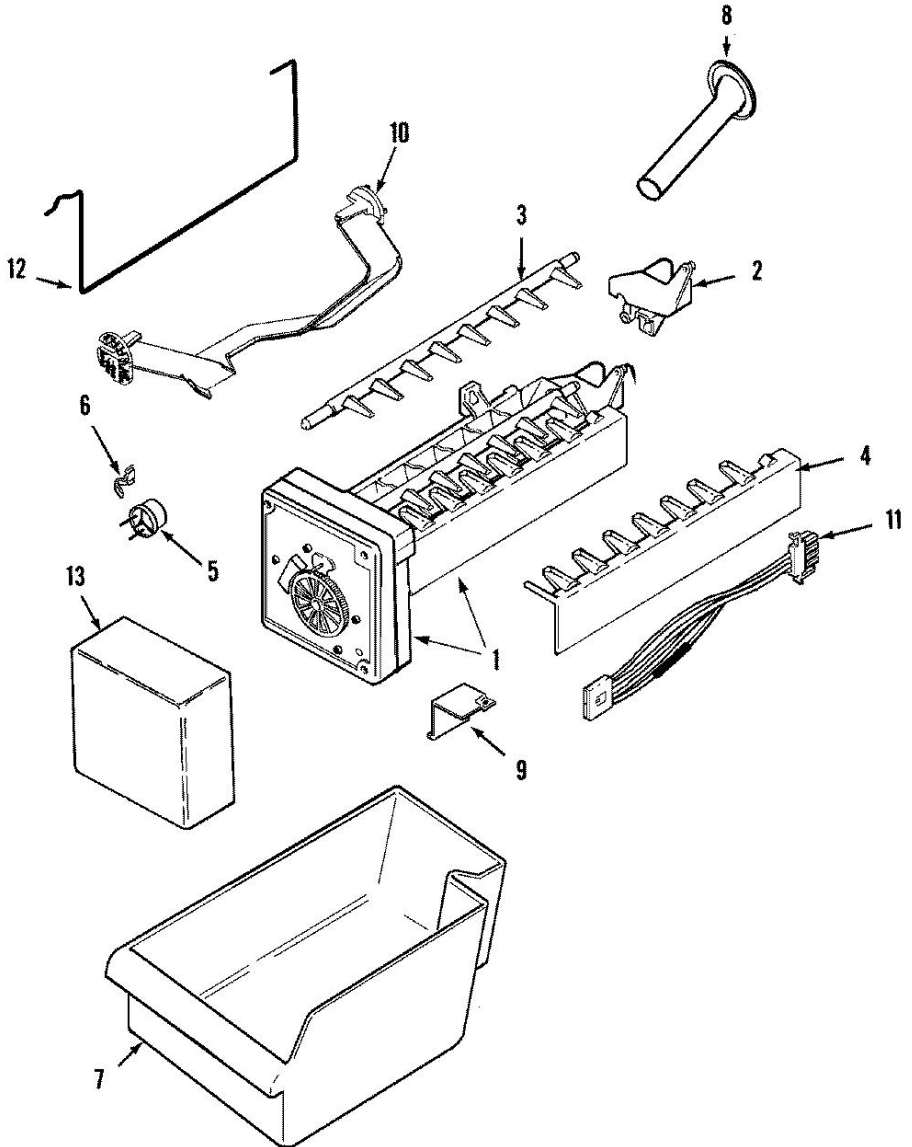



Refrigerador Maytag MTF2191ARW

Guía	N.P.	Serie	Descripción
1	61005508	Series 50	ICE MAKER ASSY.
1	63001486	Series 50	WASHER
1	63001487	Series 50	SCREW
1	63001488	Series 50	SCREW
1	95099-1	Series 50	GREASE, SILICONE
2	95100-1	Series 50	INLET, WATER
3	95101-1	Series 50	EJECTOR, ICE
4	95102-1	Series 50	STRIPPER, ICE
5	95092-1	Series 50	THERMOSTAT
5	95093-1	Series 50	CEMENT, ALUMILASTIC (4 OZ.)
6	95104-1	Series 50	RETAINER, THERMOSTAT
7	61001886	Series 50	PAN, ICE
8	61005940	Series 50	GROMMET, FILL TUBE
9	95107-1	Series 50	BRACKET, MODULE & HEATER
9	95108-1	Series 50	SCREW, BRACKET
10	61005174	Series 50	ADJUSTER, ICE LEVEL
11	61001882	Series 50	WIRE HARNESS, ICE MAKER
12	61005173	Series 50	ARM, SENSOR
12	61005175	Series 50	CLIP, SENSOR ARM
13	61005374	Series 50	COVER, ICE MAKER

Refrigerador Maytag MTF2191ARW

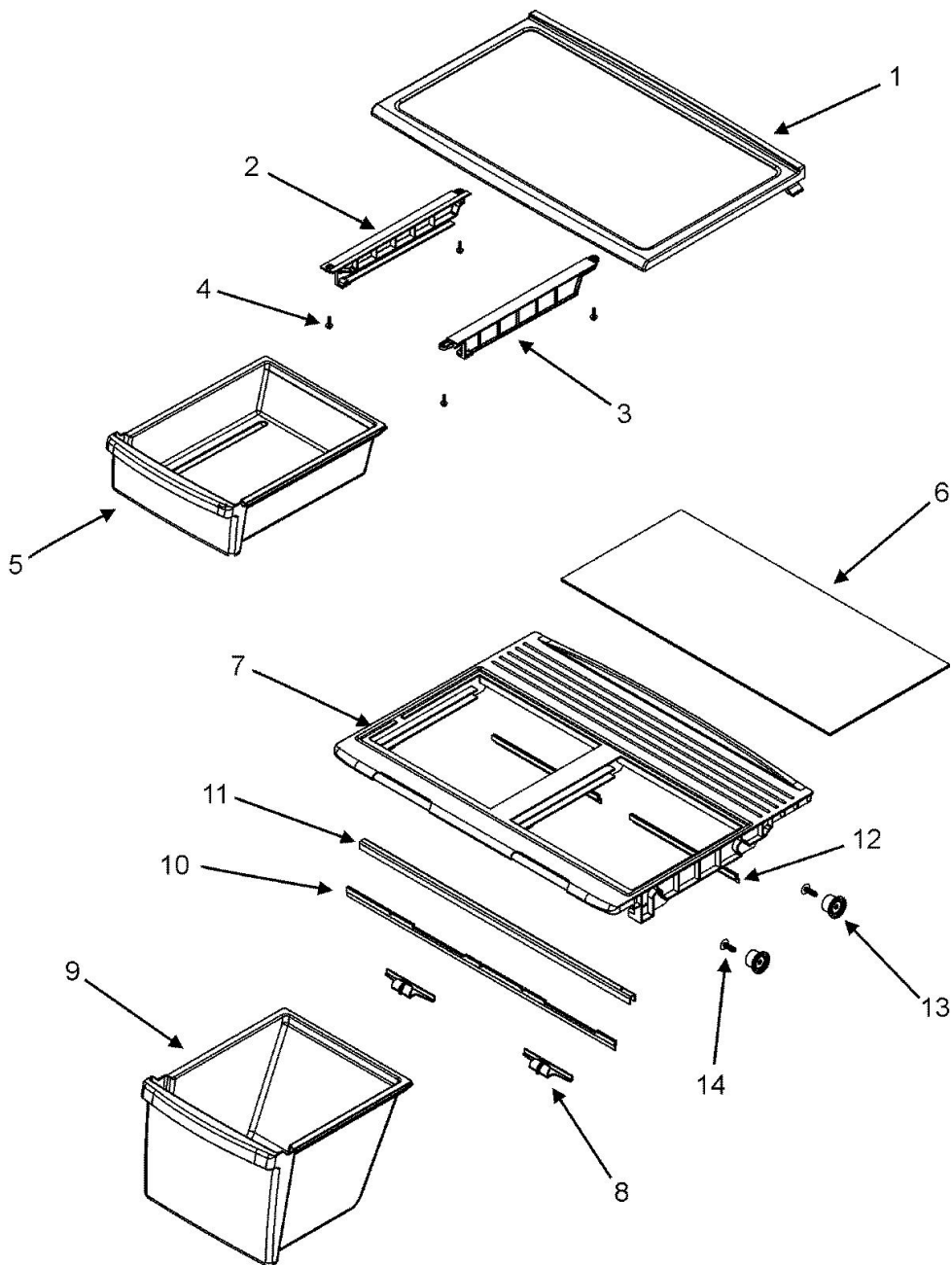



Refrigerador Maytag MTF2191ARW

Guía	N.P.	Serie	Descripción
1	63001583	Series 50	SHELF, FULL
2	63001534	Series 50	RAIL, DELI PAN (LT)
3	63001535	Series 50	RAIL, DELI PAN (RT)
4	63001318	Series 50	SCREW
5	63001584	Series 50	PAN, DELI
6	63001585	Series 50	GLASS, CRISPER SHELF
7	63001586	Series 50	SHELF, CRISPER
8	63001376	Series 50	SLIDE, CONTROL
9	63001587	Series 50	PAN, CRISPER
10	63001588	Series 50	SEAL, CRISPER SHELF (FRT)
11	63001589	Series 50	RAIL, CRISPER SUPPORT
12	63001590	Series 50	SEAL, CRISPER SHELF (REAR)
13	63001045	Series 50	SUPPORT, CRISPER SHELF
14	63001277	Series 50	SCREW