

CONTROL & BACKSPLASH

PFMS455GL0MG  
PFMS455GL0MV

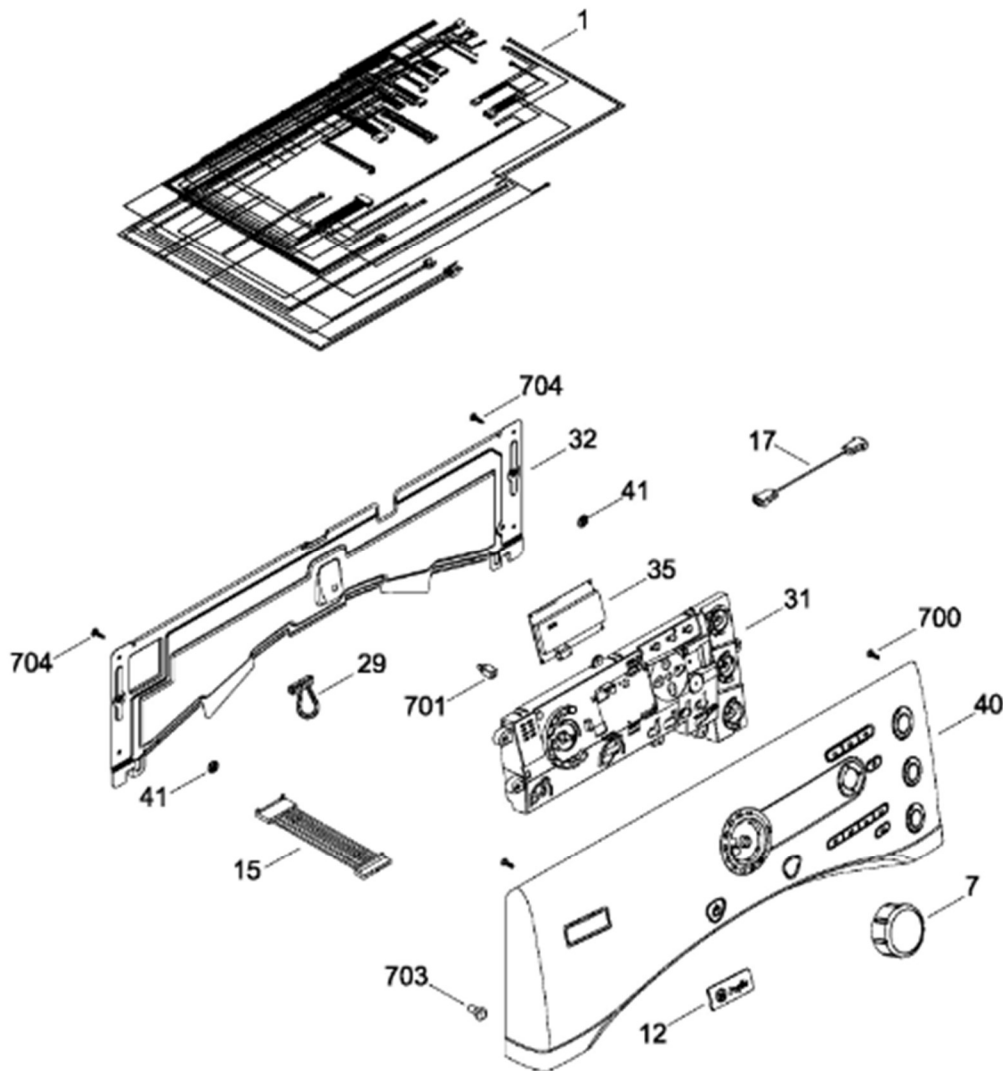

## FRONT PANEL

PFMS455GL0MG  
PFMS455GL0MV

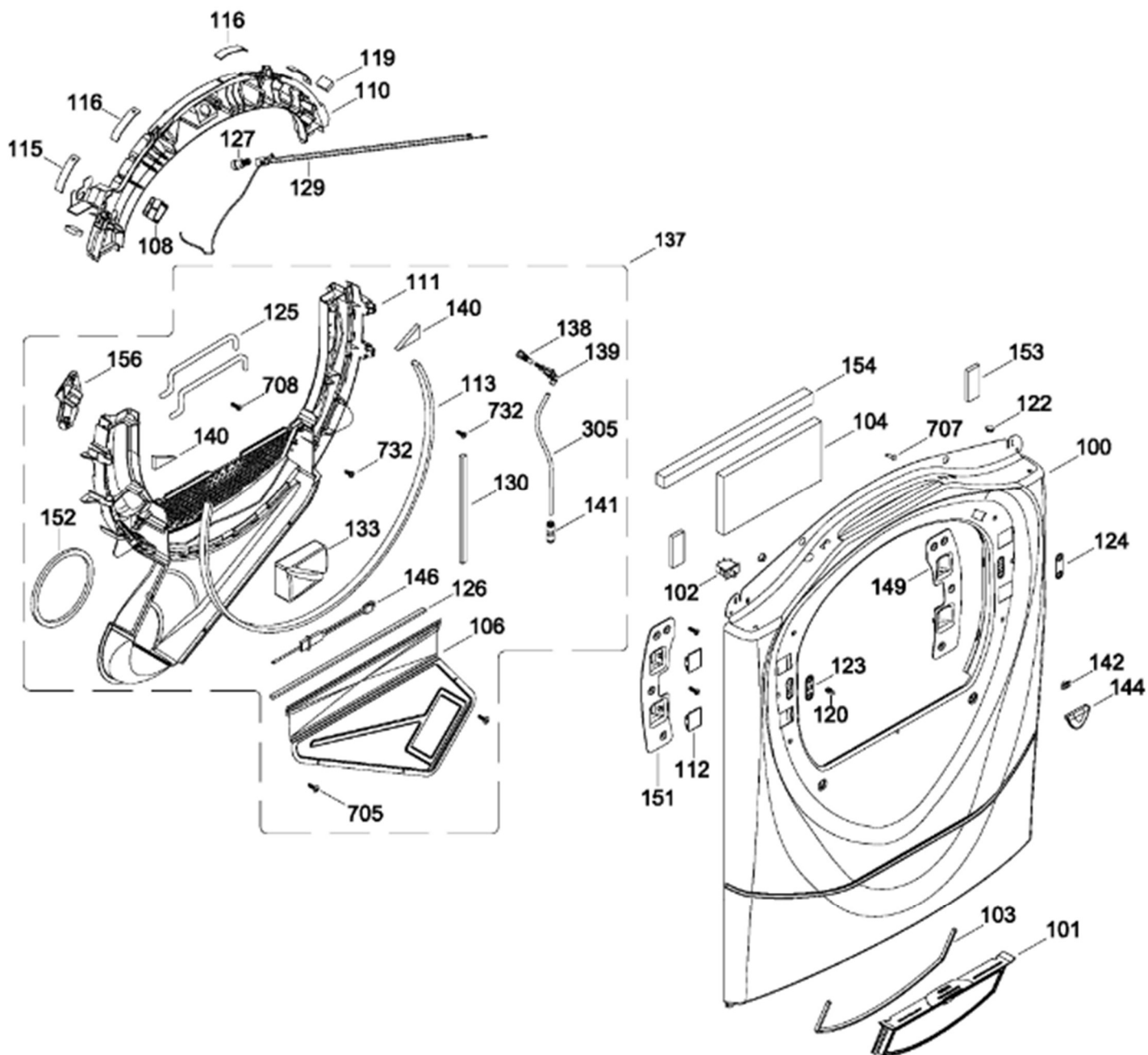

DOOR ASSEMBLY

PFMS455GL0MG  
PFMS455GL0MV

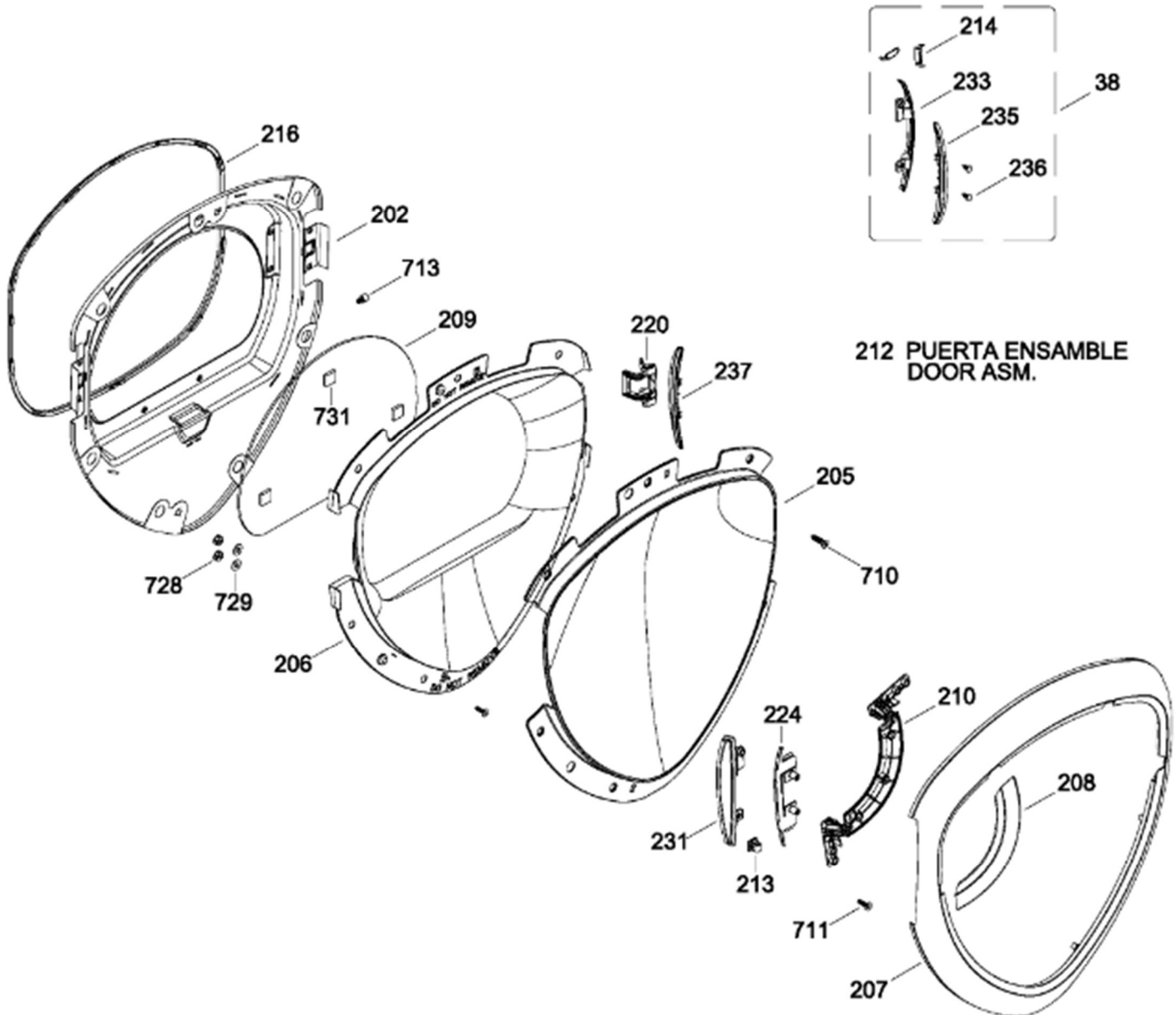

GABINETE

PFMS455GL0MG  
PFMS455GL0MV

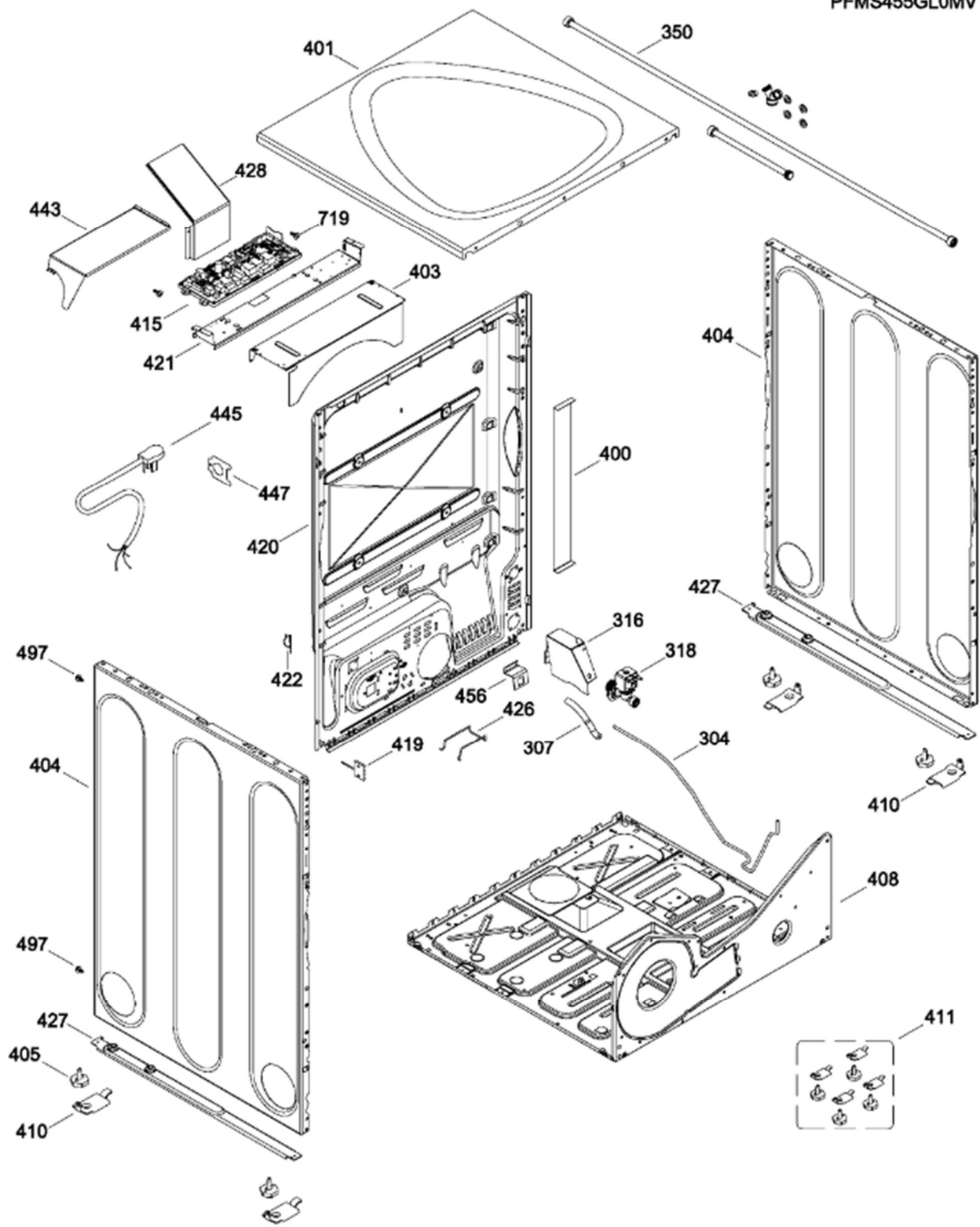

SISTEMA DE TRANSMISION / BLOWER & DRIVE ASSEMBLY

PFMS455GL0MG  
PFMS455GL0MV

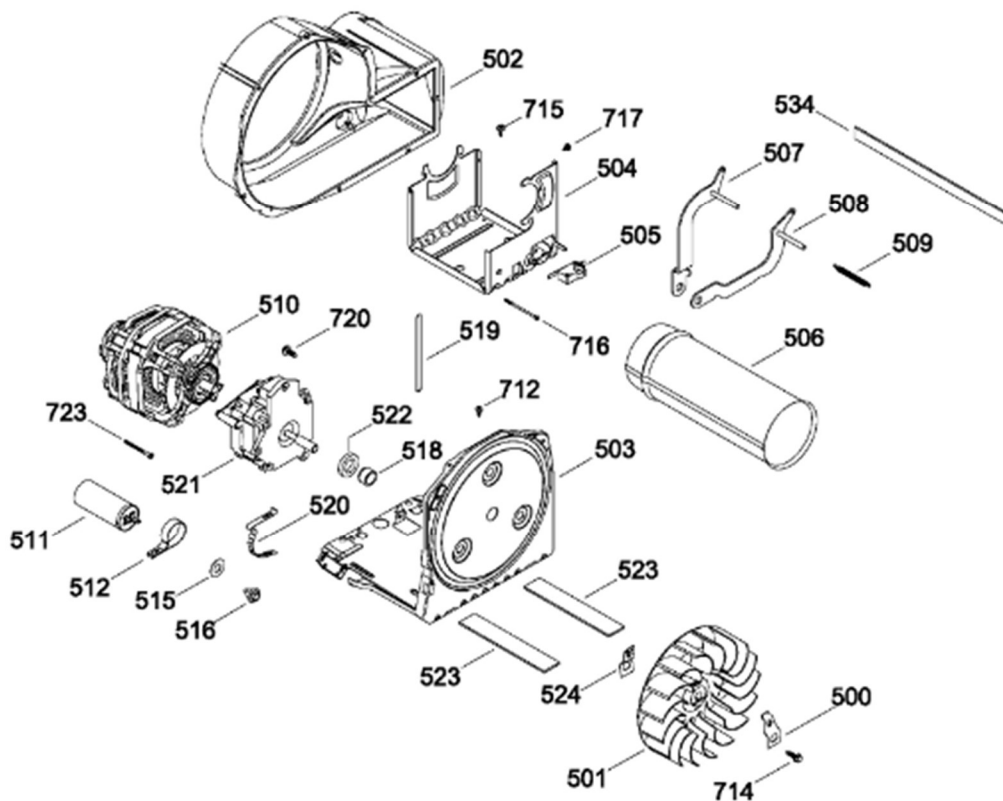

QUEMADOR / BURNER

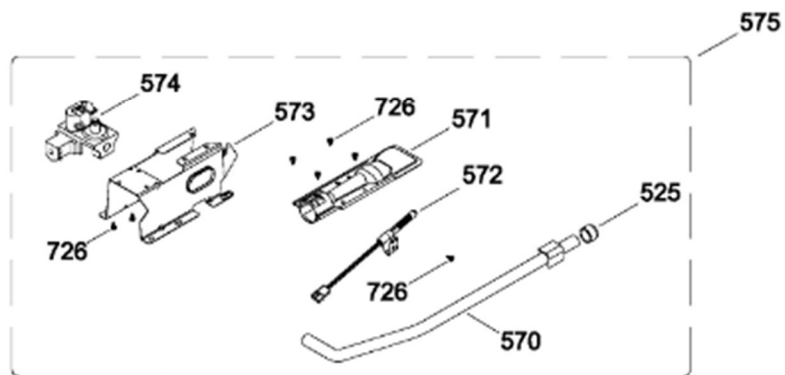

TAMBOR

PFMS455GL0MG  
PFMS455GL0MV

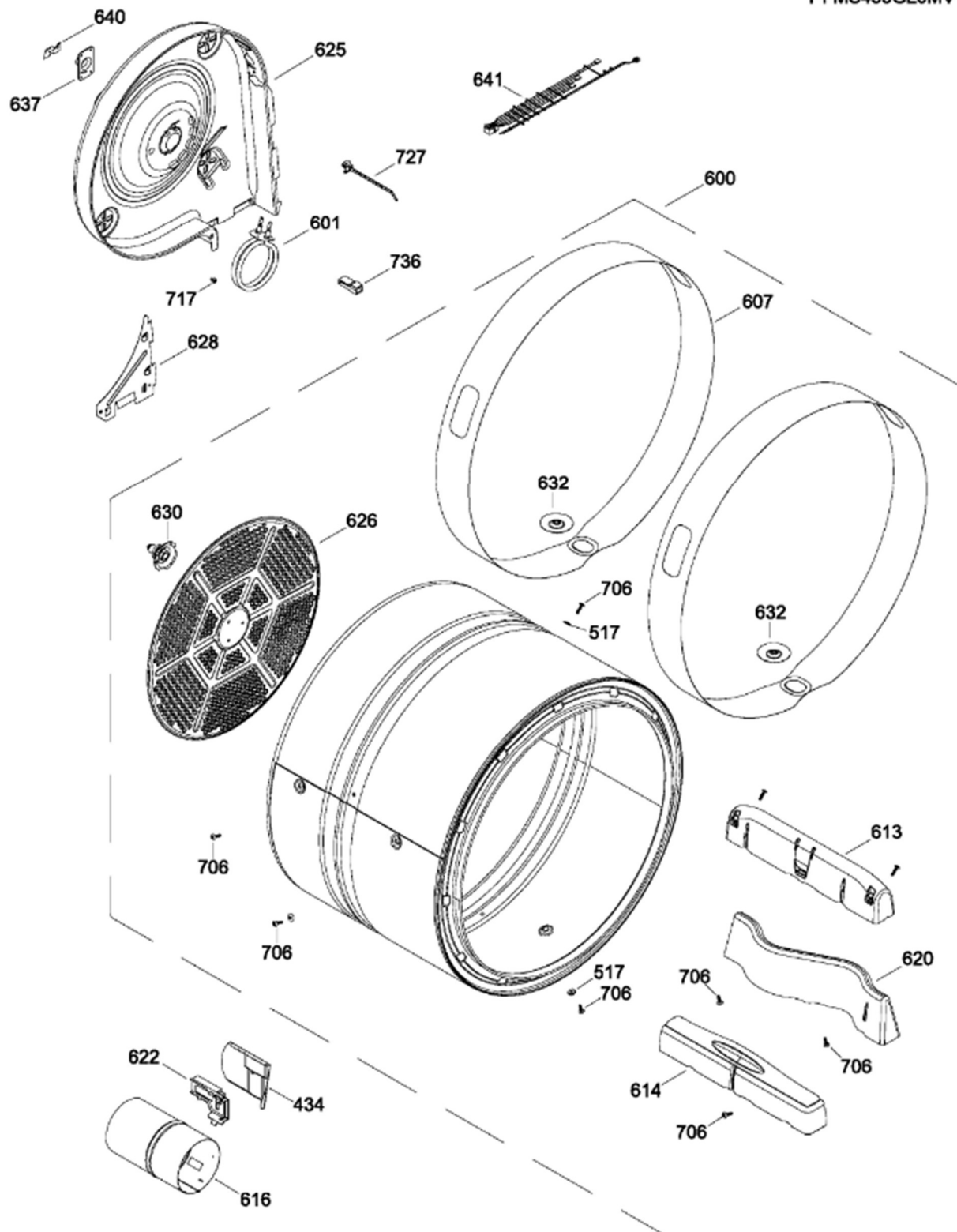

Guía	Refacción	Descripción
1	WW03F00286	ARNES MAESTRO
7	WW02L00194	BASE DE PERILLA
12	WW02A00079	BADGE GE PROFILE
15	WW02A00117	WIRING HARNESS: UI VFD AND
17	WW02F00120	COMMUNICATION CABLE (WASHER-DR
29	WW03F00287	ARNES (GAS)
31	WW03F00288	TARJETA CHASIS ENS
32	WW02L00177	FRONT SHIELD
35	WW02F00085	VFD DISPLAY BOARD
38	WW03A00140	KIT DE REVERSIBILIDAD
40	189D7162G009	PANEL FRONTAL ENS
41	WW02F00184	WHEEL FRONT SHIELD
100	212D1455P005F	FRONT PANEL MAQUILA
101	WW02L00089	FILTER + MESH ASSEMBLY
101	WW03L00186	FILTER + MESH ASSEMBLY
101	WW02F00614	MARCO Y FILTRO ENS
102	WW02L00025	INTERRUPTOR PUERTA
103	WW03L00187	SELLO FILTRO
104	WW02F00386	FRONT INSULATION
106	WW02F00179	TRAP DUCT COVER
106	WW02F00179	TRAP DUCT COVER
108	WW02L00172	DOOR SWITCH COVER
110	WW03L00284	SOPORTE SUPERIOR ENS
111	WW03A00166	DUCTO TRAMPA
112	WW02L00175	FRONT OPENING PLUG PEARL RED
113	WW02L00138	FELPA DUCTO RECOLECTOR
115	WW02A00033	BEARING_SLIDE
116	WW02L00038	BEARING_SLIDE
119	WW02A00084	CLEANING FELT
120	WW02A00004	STRIKE
122	102A3160P183	PLUG BUTTON
123	WW02A00056	STRIKE PLATE
124	WW02A00057	STRIKE PLATE
125	WW02F00088	SENSOR ROD
126	WW02L00040	GASKET FOAM
127	WW02A00067	LAMP
127	WW03F00458	LAMP

Guía	Refacción	Descripción
129	WW02F00137	HARNESS TOP BEARING (SOCKET AS
130	WW02L00042	SELLO
133	WW02F00132	FOAM SPACER- TRAP DUCT COVER
137	WW03F00290	DUCTO TRAMPA ENS
138	WW02A00092	BOQUILLA
139	WW02F00121	CODO
140	WW03F00291	FELPA DUCTO RECOLECTOR
141	WW02F00122	CONEXION DE SERVICIO
142	WW02A00093	NUT-STRIP DOOR GUIDE
144	WW02L00167	DOOR GUIDE
146	WW02F00135	HARNESS SENSORS
149	WW02L00183	HINGE BASE PART L
151	WW02L00184	HINGE BASE PART R
152	WW03L00190	SELLO DUCTO TRAMPA
152	WW03F00354	SELLO DUCTO TRAMPA
153	WW03F00292	AISLANTE BISAGRA
154	WW03L00191	AISLANTE COJINETE SUPERIOR
156	WW03A00141	SOPORTE BOQUILLA
202	WW03L00192	CONTRA PUERTA
205	WW02L00170	DOOR OUTER WINDOW
206	WW02L00169	DOOR MASK
207	WW03A00142	ANILLO EXTERIOR
208	WW03L00193	JALADERA SUPERIOR
209	WW02L00168	DOOR INNER WINDOW
210	WW03L00194	JALADERA INFERIOR
212	WW03L00195	PUERTA ENS
213	WW02L00037	LATCH ASM.
214	WW03L00196	CUBIERTA JALADERA
216	WW03L00197	SELLO PUERTA
220	WW02L00182	HINGE ASSEMBLY
224	WW02L00188	INNER DOOR CAP LEFT
231	WW03L00198	CUBIERTA PUERTA
233	WW03L00199	CUBIERTA PUERTA
235	WW03L00200	CUBIERTA BISAGRA
236	WW02A00082	BEAUTY BOTTON
237	WW03L00201	CUBIERTA BISAGRA
304	WW03F00293	TUBO POSTERIOR



Guía	Refacción	Descripción
305	WW03F00132	TUBO FRONTAL
307	WW03F00133	AISLANTE
316	WW03L00202	PROTECTOR VALVULA DE AGUA
318	WW02F00182	VALVULA DE AGUA
350	364B7057G001	KIT MANGUERAS EXTERNAS
400	WW03L00203	PLACA AMORTIGUADOR
401	212D1451P005F	CUBIERTA SUPERIOR
403	212D1495P001	PLACA POSTERIOR
404	WW02F00158	SIDE PANEL RED
405	WW02L00191	PATTE DE NIVELLEMENT
408	WW02L00156	CHASSIS BASE
410	WW02A00113	SUPPORT (PATTE DE NIVELLEMENT
411	WW02F00139	PATA NIVELADORA ENS
415	WW02F00169	TARJETA PRINCIPAL ENS.
419	WW02F00145	MOTOR CHANNEL FOAM
420	WW02L00196	REAR PANEL
420	WW02L00196	REAR PANEL
421	WW02F00140	MAIN POWER BOARD SUPPORT
422	WW02F00022	CORD SET RETAINER
426	WW03A00167	PROTECTOR ESCAPE
427	WW02F00148	MOTOR SUPPORT CHANNEL
428	WW03L00207	PROTECTOR ENSAMBLE
434	WW03L00208	PROTECTOR TERMOSTATO
443	WW03L00209	PROTECTOR VALVULA DE GAS
445	WW02F00091	CABLE TOMACORRIENTE
447	WW01A00458	TAPA TOMACORRIENTE
456	WW02A00037	BRIDE
497	WW01A00001	TORNILLO
500	WW02A00040	ABRAZADERA VENTILADOR
501	WW02A00073	VENTILADOR REDONDO
502	WW02F00107	BLOWER HOUSING
503	WW03L00246	BASE MOTOR
504	212D1456P001	U-SUPPORT
505	WW02F00138	INTERRUPTOR PRESENCIA BANDA
506	WW02F00129	EXHAUST DUCT
506	WW02F00721	EXHAUST DUCT
507	WW02A00076	ARM & PIN LEFT ASSY

Guía	Refacción	Descripción
508	WW02A00077	BRAZO Y PERNO DER ENS
509	WW02A00112	SPRING IDLER
510	WW02F00071	ENS. MOTOR POLEA
510	WW03F00445	ENS. MOTOR POLEA
511	WW01F00238	CAPACITOR
511	WW01F00342	CAPACITOR
512	WW02F00116	CAPACITOR HOLDER
515	WW02A00094	NYLON WASHER
516	WW02A00001	REVERSIBLE IDLER
517	WW02A00002	ARANDELA
518	WW02F00146	MOTOR RUBBER WASHER (GROMMET)
519	WW02F00072	BANDA
519	WW02F00896	BANDA
520	WW02F00031	CLIP MOTOR
521	WW02A00053	BLOWER MOTOR (w/control)
522	WW02A00068	BLOWER MOTOR FOAM
523	WW02A00075	ABSORBER FOAM
524	WW02A00041	ABRAZADERA VENTILADOR
525	WW02A00003	TAPA
534	WW02A00026	EMPAQUE ESCAPE SOPLADOR
534	WW02F00785	EMPAQUE ESCAPE SOPLADOR
570	WW02A00058	PIPE & LUG ASM.
570	WW03F00137	PIPE & LUG ASM.
571	WW02A00020	QUEMADORES
572	WW02F00002	ALLUME-GAZ
572	WW02F00740	ALLUME-GAZ
572	WW01F01432	ENCENDEDOR INCANDESCENTE
573	WW02F00077	GAS VALVE BRACKET
573	WW03A00125	GAS VALVE BRACKET
574	WW02F00100	2-STAGE GAS VALVE
575	WW02F00073	VALVULA DE GAS Y SOPORTE ENS
600	WW03F00295	ENS TAMBOR 7.5 ENTERPRISE/S
601	WW02F00115	CALROD
607	WW02L00098	BANDA TAMBOR
613	WW02F00133	HANG DRY BAFFLE ASSEMBLY
614	WW02L00153	BAFFLE AND SCREEN ASSEMBLY
616	WW02F00119	COMBUSTION CHAMBER

Guía	Refacción	Descripción
620	WW02F00153	S-BAFFLE
622	WW02F00001	DETECTOR TERMOSTATO
625	WW02L00014	DIFUSOR GAS
625	WW03F00095	DIFUSOR GAS
626	WW02F00030	DIFUSOR
628	WW02F00029	DIFUSSER PLATE
630	WW02A00019	SOPORTE Y FLECHA ENSAMBLE
632	WW02A00072	RONDANDA BANDA
637	WW02A00005	RETENEDOR RODAMIENTO
640	WW02F00026	GROUND STRAP ASM.
640	WW01A00443	GROUND STRAP ASM.
640	WW02F00833	GROUND STRAP ASSEMBLY
641	WW03F00298	ARNES DERECHO
700	WW02A00102	SCREW CHASSIS TO FRONT HSG.
701	WW02A00087	ENCLOSED SCREW GROMMET
703	WW02A00105	SCREW WHEEL MOUNTING
704	WW02A00103	SCREW RED
705	WW02A00028	TORNILLO
706	WW02A00031	TORNILLO
707	WW02A00097	SCREW
708	WW02A00098	SCREW
708	WW01A00539	SCREW
710	WW02A00100	SCREW #8 FOR DOOR HINGE CAP
711	WW02A00101	TORNILLO
712	WW02A00029	TORNILLO
712	WW02A00211	TORNILLO
713	WW02A00074	3/16 HEX FEMAL SCREW
714	WW02A00071	TORNILLO
715	WW02A00070	TORNILLO
716	WW02A00032	TORNILLO
717	WW02A00030	TORNILLO
717	WW02A00211	TORNILLO
719	WW02A00106	SCREWS
719	WW02A00229	SCREWS
720	WW02A00096	SCREW
723	WW03A00145	TORNILLO HI/LO 8-18
726	WW02A00027	SCREW

<b>Guía</b>	<b>Refacción</b>	<b>Descripción</b>
727	WW02A00061	TIE WRAP ARNESS
727	WW02F00402	TIE WRAP ARNESS
728	WW02A00114	TUERCAS
729	WW03A00146	ARANDELAS
731	WW03A00147	CALZA
732	WW03A00092	TORNILLO 6-16 B B1Q1 3/4
736	WW03A00159	PROTECTOR TERMINALES