

Distribuidor Autorizado

SurteRápido.com

Venta de Refacciones
Electrodomesticas

Refrigerador Mabe RMT1951VMXSB

PUERTA

RMT1951VMXSB

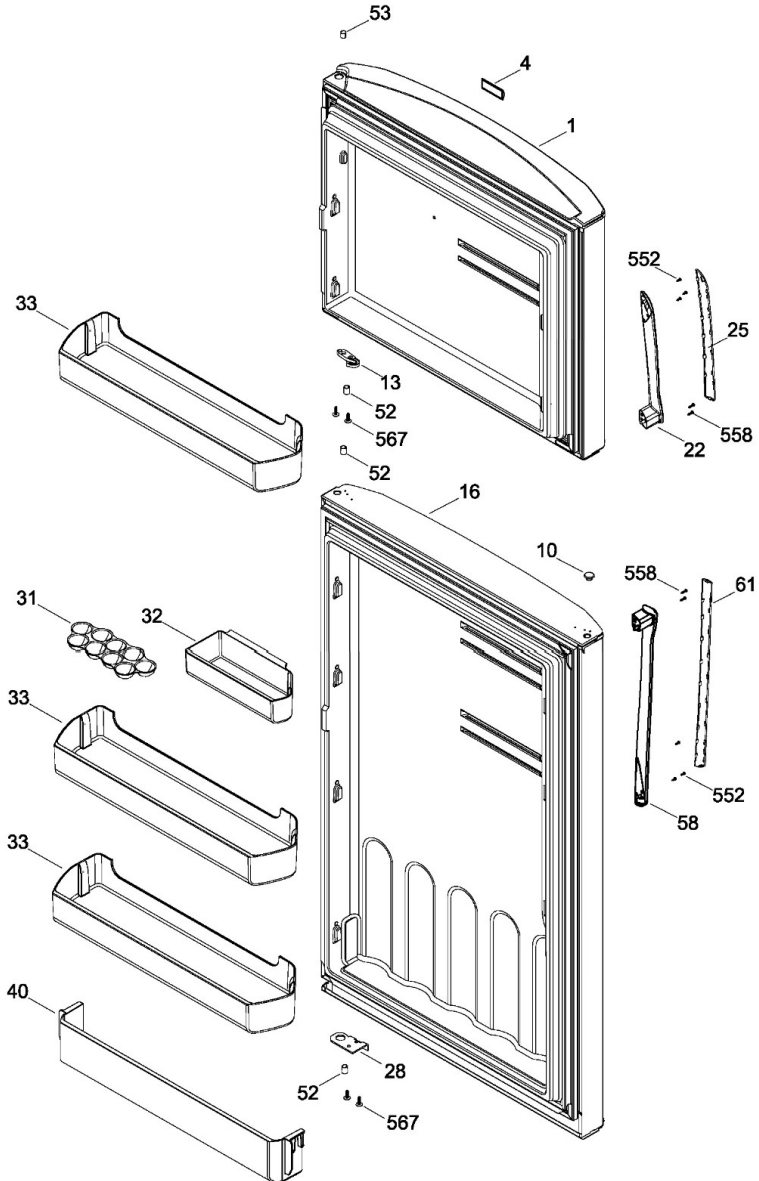

Distribuidor Autorizado

SurteRápido.com

Venta de Refacciones
Electrodomesticas

Refrigerador Mabe RMT1951VMXSB

GABINETE

RMT1951VMXSB

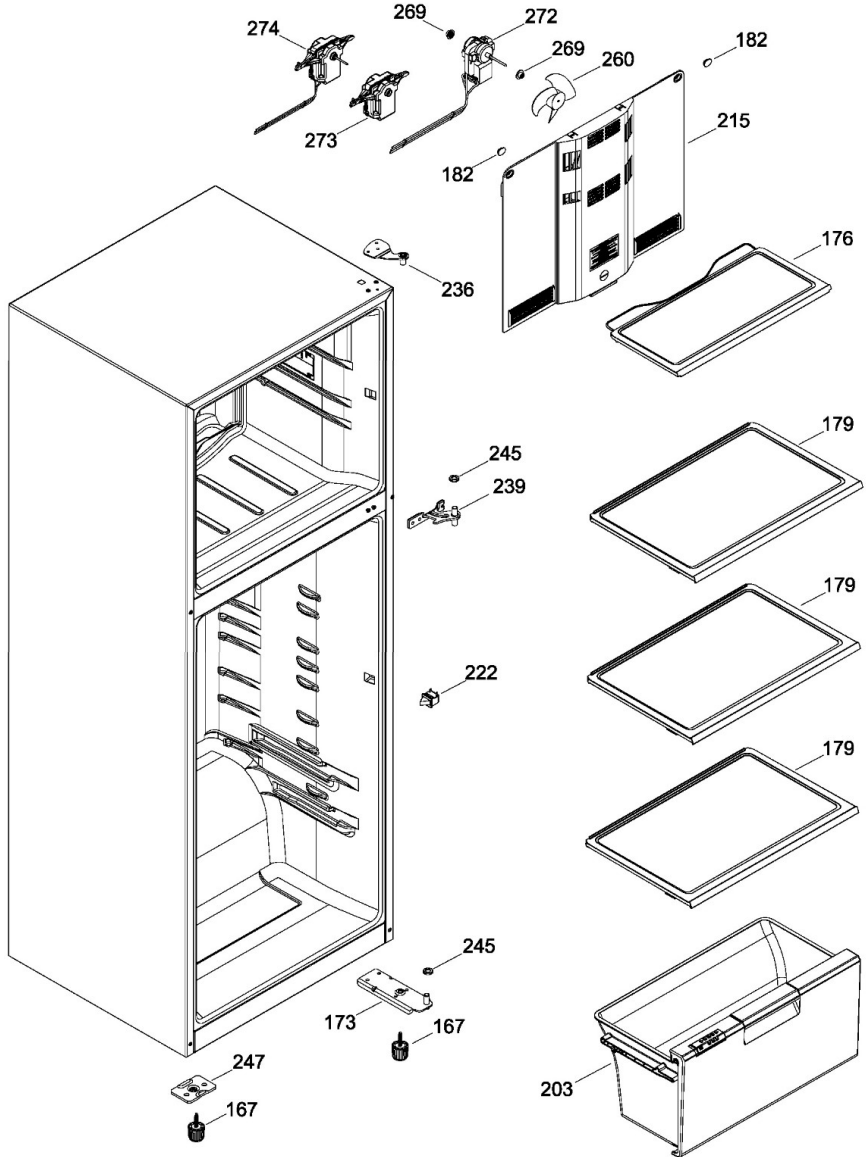

Distribuidor Autorizado

SurteRápido.com

Venta de Refacciones
Electrodomesticas

Refrigerador Mabe RMT1951VMXSB

UNIDAD REFRIGERANTE

RMT1951VMXSB

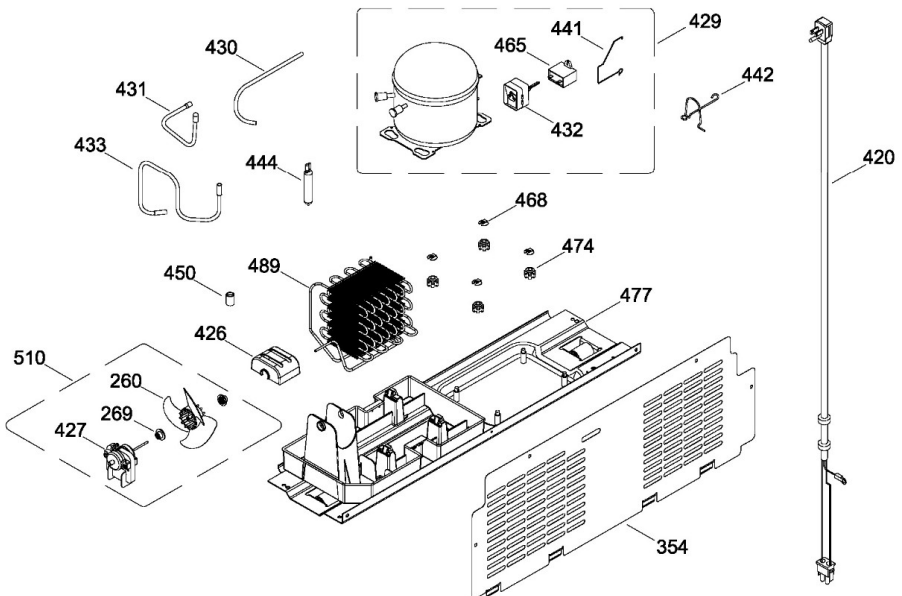
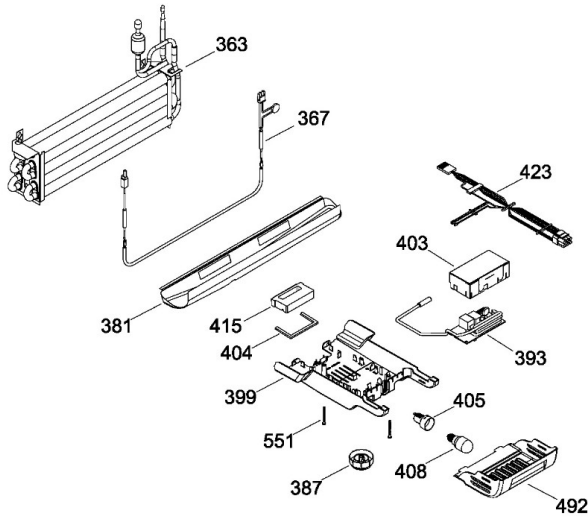

Distribuidor Autorizado

SurteRápido.com

Venta de Refacciones
Electrodomesticas



Refrigerador Mabe RMT1951VMXSB

Guía	Componente	Descripción
1	225D6416G022	PUERTA CONGELADOR CURVA (GRIS)
1	225D6416G002	PUERTA CONGELADOR CURVA (GRIS)
4	277B1234P002	PLACA EMBLEMA SIRIUS 360
10	238C1221P008	TAPON BUJE
13	355B1499P006	TOPE PUERTA INTERMEDIO
16	225D6417G014	PUERTA CONSERVADOR CURVA(GRIS)
16	225D6417G002	PUERTA CONSERVADOR CURVA(GRIS)
16	225D8938G005	PTA.FF.ESP.MB.P88.S/D.AGUA(510
16	225D8938G019	KIT DE PUERTAS PLATA 89 RMT1951VMXS
22	225D4146P005	BASE JALADERA
22	225D4146P008	BASE JALADERA
25	225D4148P011	INSERTO LITTLE SWAN S/HS.FZ
28	238C2106P001	TOPE PUERTA REFRIGERADOR
31	238C1489P003	CHAROLA DE HUEVOS TRANSP MABE
31	238C4768P001	CHAROLA DE HUEVOS TRANSP MABE
32	225D6142P001	ANAQUEL
33	225D6144P001	ANAQUEL
40	225D6146P001	ANAQUEL
52	238C2207P001	BUJE BISA 1GRA
53	355B2134P001	BUSHING HINGE
58	225D4147P005	BASE JALADERA
58	225D4147P008	BASE JALADERA
61	225D4149P011	INSERTO LITTLE SWAN S/HS.FF
167	314B8640P010	TORNILLO NIVELADOR
173	200D3283G009	SOP.BIS.INF.ENS.PERNO REMACHADO
176	225D6049G002	PARRILLA CONG. ENS.
179	225D6046G002	PARRILLA REFR. ENS.
182	355B2012P001	BOTON

Distribuidor Autorizado

SurteRápido.com

Venta de Refacciones
Electrodomesticas



Refrigerador Mabe RMT1951VMXSB

Guía	Componente	Descripción
203	225D6052G004	CAJON LEGUMBRES ENS
203	225D6052G011	CAJON LEGUMBRES ENS
215	225D6465G002	ENS. CUBIERTA EVAPORADOR
222	314B8274P003	INTERRUPTOR FOCO
236	238C2735G006	BISAGRA SEPARADOR ENS.
239	355B3920G001	BISAGRA INTERMEDIA ENS.
245	238C4764P001	ESPACIADOR PUERTA SIRIUS 360
247	238C3963P001	SOPORTE NIVELADOR
260	197D3131G006	ASPA DE VENTILADOR ENS
269	221C5143P001	EMPAQUE VENTILADOR
272	200D2940P025	MOTOR VENTILADOR FZ.127V.S.360
273	225D6193P001	CUBIERTA MOTOR
274	225D6184G003	ENS. MOTOR VENTILADOR
274	225D6184G001	ENS. MOTOR VENTILADOR
354	225D2317P004	TAPA COMPRESOR
363	225D6018G030	EVAPORADOR ENS 127V
367	225D7049G015	ARNES RESIST"X"127V(510LT)COMP
381	225D5671P002	CHAROLA DESHIELO
387	238C4460P002	PERILLA CONTROL
393	200D9607G013	TARJETA CONTROL
393	225D7291G008	TARJETA CONTROL
399	225D6217P001	CAJA CONTROL
403	225D6218P001	CAJA PROTEC.TARJETA(X/Y)S/DISP
404	355B3705P001	SELLO DE ESPUMA
405	238C2927P001	SOCKET ENS.
408	238C2688P001	FOCO FF
408	238C4973P001	FOCO FF
408	238C4973P003	FOCO LED 130V (1.5W)

Distribuidor Autorizado

SurteRápido.com

Venta de Refacciones
Electrodomesticas



Refrigerador Mabe RMT1951VMXSB

Guía	Componente	Descripción
415	238C4573P001	DUCTO SENS.OR AIRE
420	225D6117G002	ARNES TOMACORR.127V SIR.360
420	225D6117G007	ARNES TOMACORR.127V SIR.360
423	225D7048G001	ARNES CAJA CONTROL SIRIUS 360
426	238C2142P001	CLIP MOTOR COND.
426	238C2142P002	CLIP MOTOR COND.
427	200D2940P023	MOTOR VENTILADOR
427	200D2940P032	MOTOR VENTILADOR
429	200D3627G008	ENS. COMPRESOR ACEITE
430	355B1400P002	APEND.TUBO CARGA 400-510.115V
431	314B9038P004	APENDICE DE SERVICIO 85MM
432	200D5578P005	ACCS ELEC 5SP16B308RH
433	238C1761P001	TUBO APENDICE SUCCION 15'16'18
441	355B2089P010	CLIP 5SP 127V GLOBE CAPACITOR
442	355B2089P012	CLIP CONECTOR
444	221C5100P008	FILTRO DESHIDRATADOR
450	355B1473P001	VALVULA DREN
465	238C2606P002	CAPACITOR
468	238C4369P001	AMORTIGUADOR
474	871516P006	CLIP COMPRESOR
477	200D2405G004	ENS. SOPORTE COMPRESOR
477	200D2405G005	ENS. SOPORTE COMPRESOR
489	200D3706P003	CONDENS.ADOR MULTILAYER
492	225D6059P001	CUBIERTA LUZ
510	355B1403G005	MOTOR ASPA ENS.
551	314B8355P001	TORNILLO 8-19
552	314B8114P001	TORNILLO C/PHILL.(8-32X12.7MM.