

Distribuidor Autorizado

SurteRápido.com

Venta de Refacciones  
Electrodomesticas

# SECADORA SEGE1530IA2BR1

SISTEMA CONTROLES

SEGE1530IA2BR1

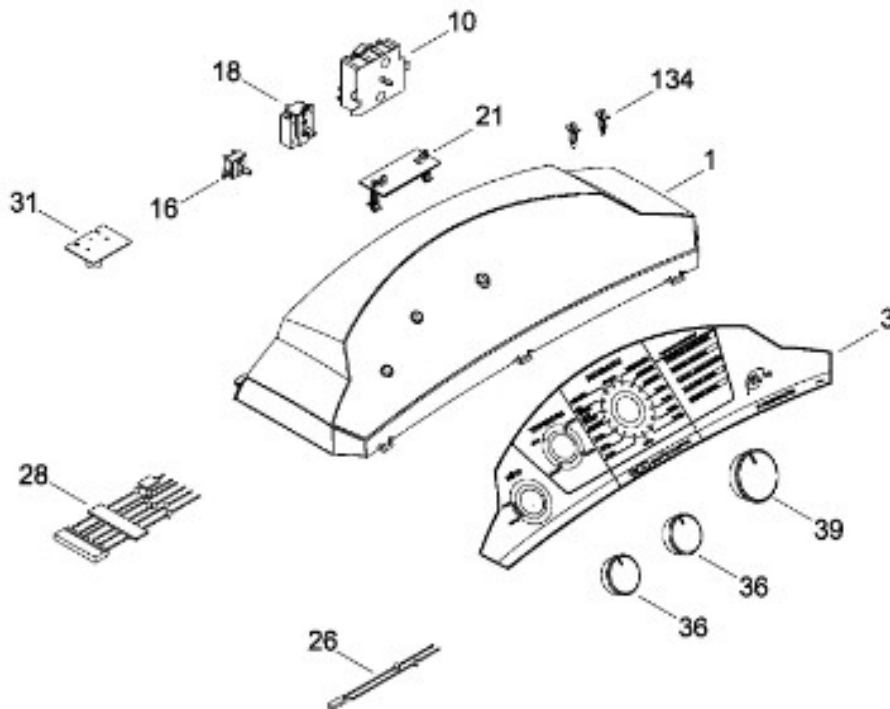

Distribuidor Autorizado

SurteRápido.com

Venta de Refacciones  
Electrodomesticas

# SECADORA SEGE1530IA2BR1

PUERTA (ENS)

SEGE1530IA2BR1

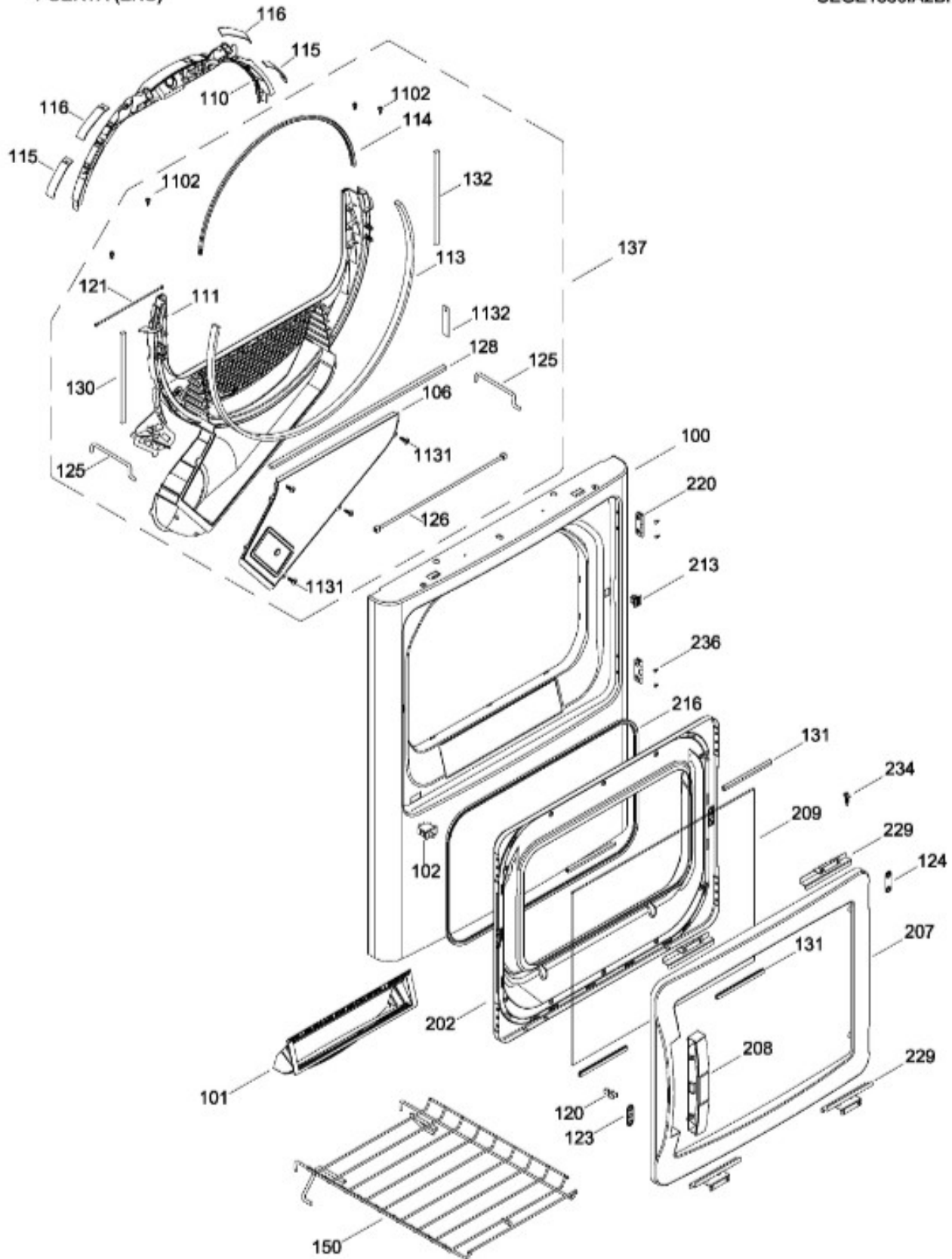

Distribuidor Autorizado

SurteRápido.com

Venta de Refacciones  
Electrodomesticas

# SECADORA SEGE1530IA2BR1

GABINETE

SEGE1530IA2BR1

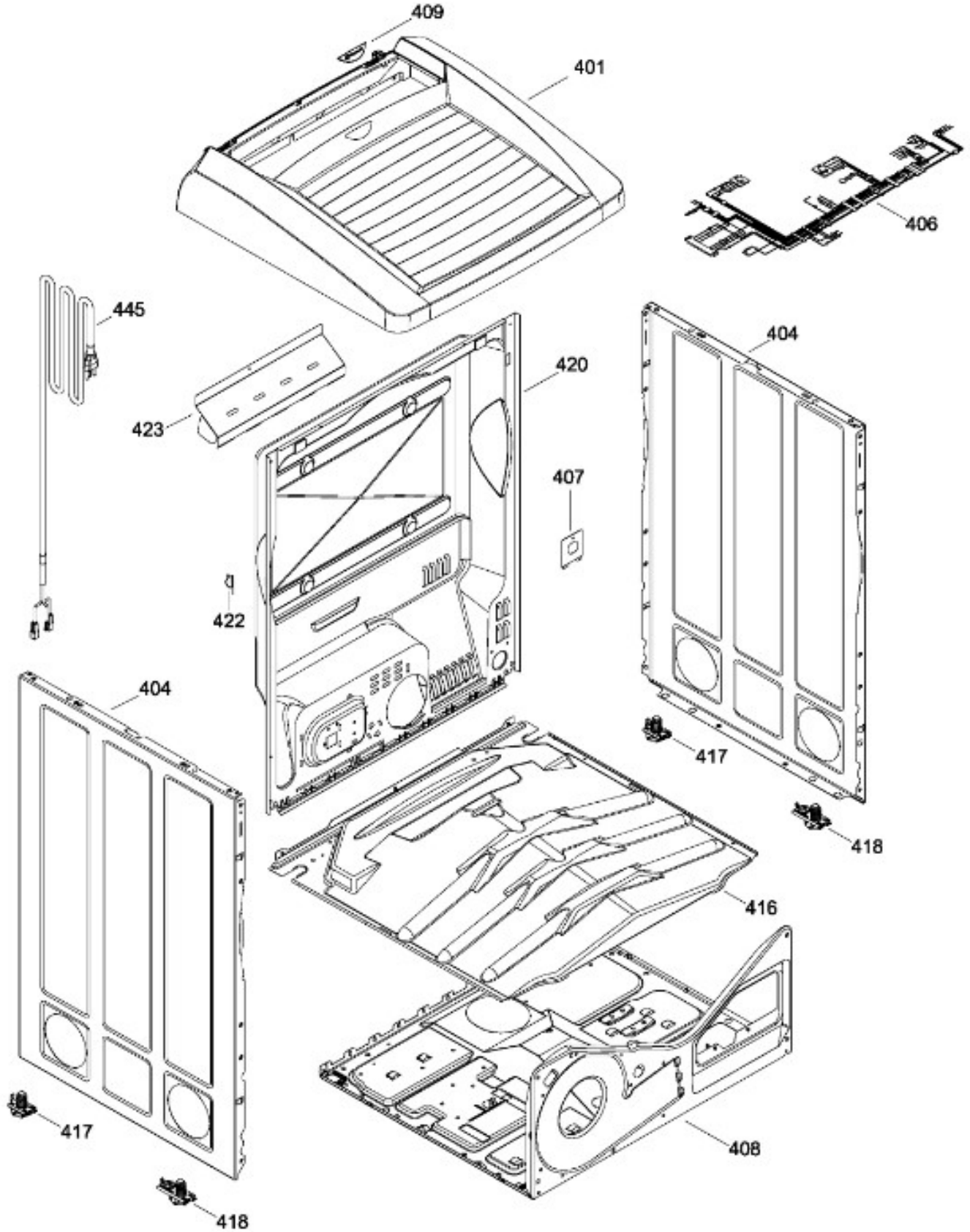

Distribuidor Autorizado

SurteRápido.com

Venta de Refacciones  
Electrodomesticas

# SECADORA SEGE1530IA2BR1

SISTEMA DE TRANSMISION / BLOWER & DRIVE ASSEMBLY

SEGE1530IA2BR1

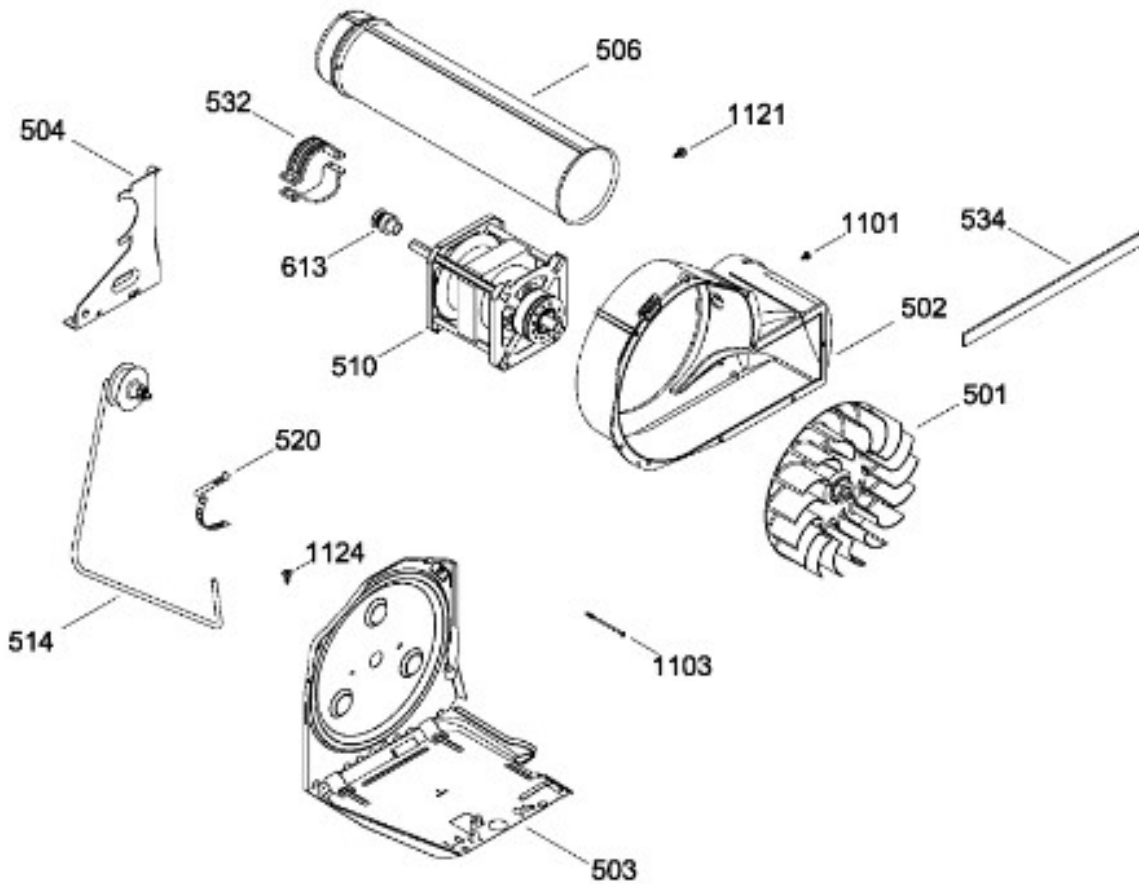

Distribuidor Autorizado

SurteRápido.com

Venta de Refacciones  
Electrodomesticas

# SECADORA SEGE1530IA2BR1

TAMBOR

SEGE1530IA2BR1

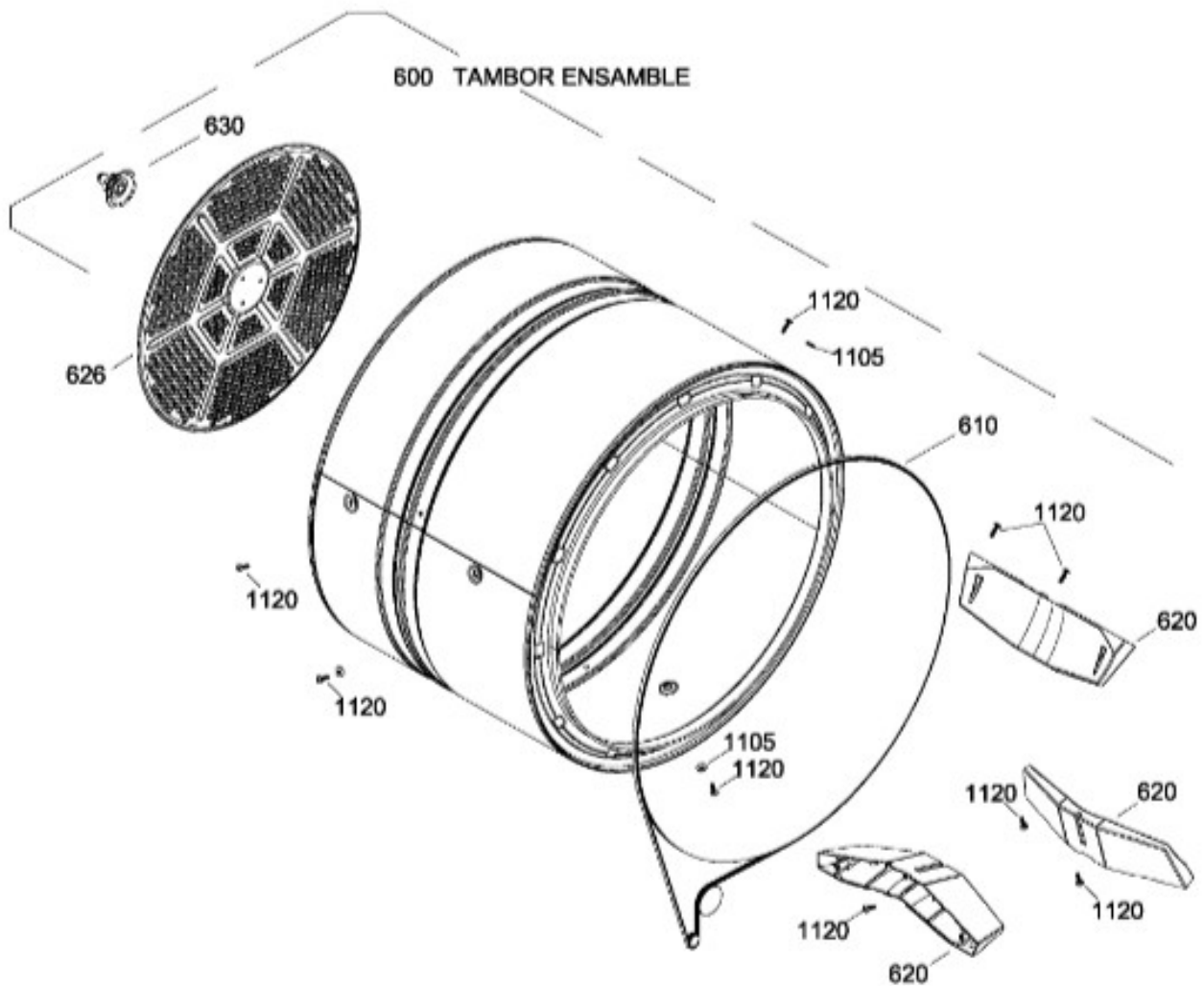
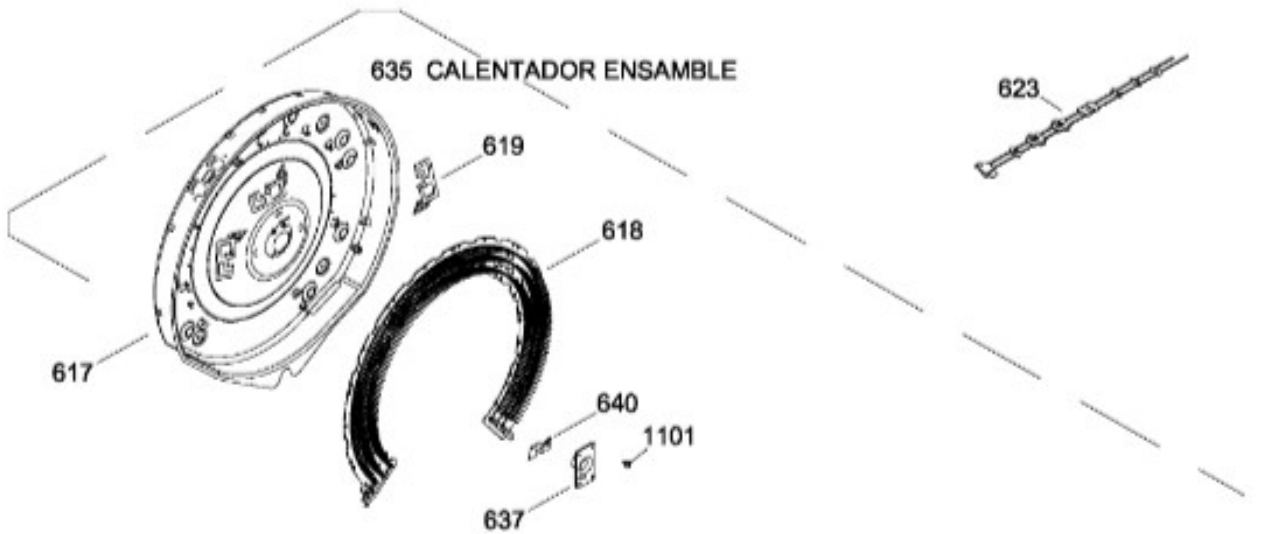

Distribuidor Autorizado

**SurteRápido.com**

Venta de Refacciones  
Electrodomesticas

# SECADORA SEGE1530IA2BR1

Guía	Refacción	Descripción
1	WW02L00059	COPETE
3	WW02F00151	OVERLAY
10	212D1233P020	RELOJ
16	WW02L00083	INTERRUPTOR DE INICIO
18	WW02L00086	INTERRUPTOR ROTATORIO
21	WW02F00090	RESISTENCIA ENS.
26	WW02A00048	JUMPER
28	WW02A00047	CIRCUITO IMPRESO
31	WW02F00092	TARJETA PC
36	WW01L00485	PERILLA ROTATORIA
39	WW02L00205	ENS. PERILLA CONTROL
39	WW01L00486	ENS. PERILLA CONTROL
100	WW02L00049	PANEL FRONTAL
101	WW02L00150	FILTRO
102	WW02L00025	INTERRUPTOR PUERTA
106	WW02L00061	CUBIERTA DUCTO
110	WW02F00010	COJINETE SUP.
110	WW01L01430	COJINETE SUP.
111	WW02F00178	TRAMPA CONDUCTO
111	WW02L00103	TRAMPA CONDUCTO
111	WW02F00600	DUCTO
113	WW02L00138	FELPA DUCTO RECOLECTOR
114	WW02L00145	SELLO PUERTA
115	WW02A00033	BEARING_SLIDE
116	WW02L00038	BEARING_SLIDE
120	WW02A00004	STRIKE
121	WW02A00051	ARNES
123	WW02A00056	STRIKE PLATE
124	WW02A00057	STRIKE PLATE
125	WW02F00088	SENSOR ROD
126	WW02A00052	ARNES
128	WW02L00040	GASKET FOAM
130	WW02L00042	SELLO
131	WW02L00102	RETAINER GASKET
132	WW02L00039	SELLO

Distribuidor Autorizado

**SurteRápido.com**

Venta de Refacciones  
Electrodomesticas

# SECADORA SEGE1530IA2BR1

Guía	Refacción	Descripción
132	WW03F00354	SELLO
134	WW02A00035	SOPORTE BLOQUEO
137	WW02F00128	DUCTO TRAMPA ENS CON SENSORES
137	WW02F00599	DUCTO TRAMPA ENS CON SENSORES
150	WW02L00088	SHOE RACK
150	WW02L00190	SHOE RACK
202	WW02L00052	PUERTA INTERIOR
202	WW02L00052	PUERTA INTERIOR
202	WW02L00052	PUERTA INTERIOR(BLANCA)
207	WW02F00032	ANILLO EXT.
208	WW02L00055	JALADERA
209	189D5237P002	VIDRIO TEMPLADO
213	WW02L00037	LATCH ASM.
216	WW02L00062	SELLO VENTANA
220	WW02L00029	BISAGRA
220	WW02L00028	BISAGRA
229	WW02L00101	SOPORTE VIDRIO
229	WW02L00101	SOPORTE VIDRIO
229	WW02L00101	SOPORTE VIDRIO
234	WW02A00036	LIBERADOR TENS.IONES
236	WW02A00065	BOTON BELLEZA
401	189D5116P004	CUBIERTA SUPERIOR(BCO)
401	WW02L00067	ENS. CUBIERTA SUP. PLASTICA
404	WW02L00149	PANEL LATERAL
404	WW02L00149	PANEL LATERAL
404	WW02L00149	PANEL LATERAL
406	189D7139G010	ARNES ENSAMBLE ELECTRICO
407	WW02L00141	CUBIERTA
408	WW02F00076	BASTIDOR BASE
409	WW02L00111	LOGO GE
416	WW02A00045	DEFLECTOR
416	WW02A00045	DEFLECTOR
416	WW02A00045	DELFECTOR DE CALOR
417	WW02A00059	ENS. SOPORTE POST.
418	WW02L00108	ENS. SOPORTE FRONT.

Distribuidor Autorizado

**SurteRápido.com**

Venta de Refacciones  
Electrodomesticas

## SECADORA SEGE1530IA2BR1

Guía	Refacción	Descripción
420	WW02L00146	PANEL POST.
422	WW02F00022	CORD SET RETAINER
423	WW02L00107	ESCUDO CALOR POST.
445	WW02F00124	CORDON TOMACORRIENTE
501	WW02A00011	SOPLADOR PUERTA
501	WW01F01162	SOPLADOR PUERTA
502	WW02A00012	CARCAZA ASPAS
502	WW02L00013	CARCAZA ASPAS
502	WW02L00433	CAJA DEL VENTILADOR
503	WW01F01125	BASE MOTOR
503	WW01L01163	BASE MOTOR
503	WW01L01163	BASE MOTOR
503	WW02L00642	BASE MOTOR
504	WW02F00027	SOPORTE MOTOR
506	572D559P006	CONDUCTO DE ESCAPE
510	WW02F00062	MOTOR
514	WW02A00008	ENS. BRAZO AUXILIAR
514	WW03F00350	ENS. BRAZO AUXILIAR
520	WW02F00031	CLIP MOTOR
532	WW02F00003	CORREA MOTOR
532	WW02A00232	CORREA MOTOR
534	WW02A00026	EMPAQUE ESCAPE SOPLADOR
534	WW02F00785	EMPAQUE ESCAPE SOPLADOR
600	WW02F00057	ENS. TAMBOR
610	WW02F00028	BANDA SECADORA
610	WW02F00854	BANDA SECADORA
613	WW01F01118	POLEA DE TRANSMISION
617	WW03L00152	CUBIERTA CALENTADOR
618	WW01F01164	CALENTADOR ENS
619	WW01A00442	SOPORTE DE PROTECCION
620	WW02L00143	BAFFLE
623	WW02F00049	ARNES
626	WW02F00030	DIFUSOR
630	WW02A00019	SOPORTE Y FLECHA ENSAMBLE
635	189D7110G007	CALENTADOR ENSAMBLE



Distribuidor Autorizado

**SurteRápido.com**

Venta de Refacciones  
Electrodomesticas

## SECADORA SEGE1530IA2BR1

Guía	Refacción	Descripción
637	WW02A00005	RETENEDOR RODAMIENTO
640	WW02F00026	GROUND STRAP ASM.
640	WW01A00443	GROUND STRAP ASM.
640	WW02F00833	GROUND STRAP ASSEMBLY
1101	WW02A00030	TORNILLO
1101	WW02A00211	TORNILLO
1102	WW02A00029	TORNILLO
1102	WW02A00211	TORNILLO
1103	WW02A00032	TORNILLO
1105	WW02A00002	ARANDELA
1120	WW02A00031	TORNILLO
1121	WW01A00001	TORNILLO
1124	WW02A00070	TORNILLO
1131	WW02A00028	TORNILLO
1132	WW02L00033	ESPACIADOR ESPUMADO