

SISTEMA CONTROLES

SEL1545PXPB0

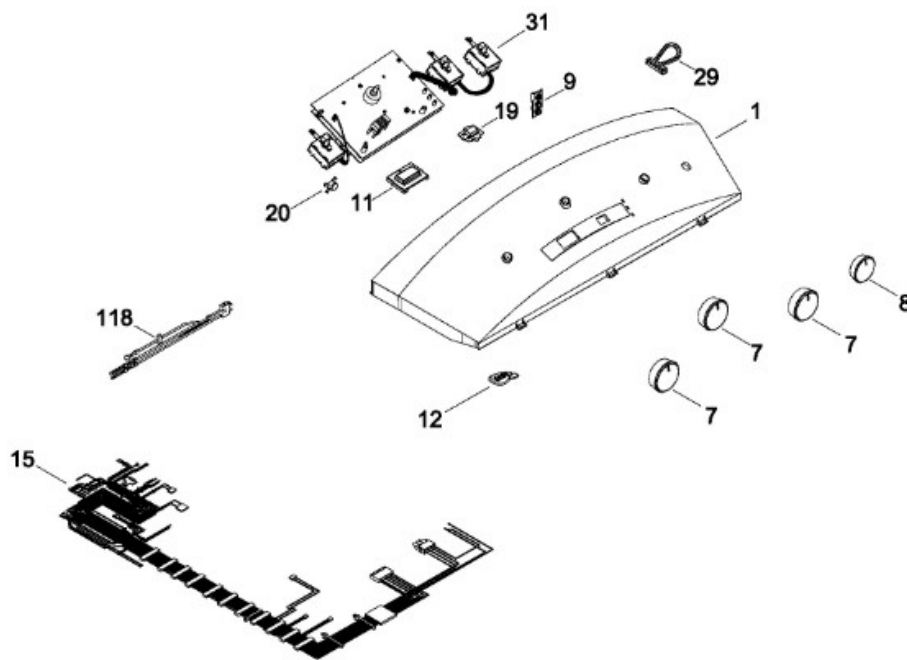

PUERTA (ENS)

SEL1545PXPB0

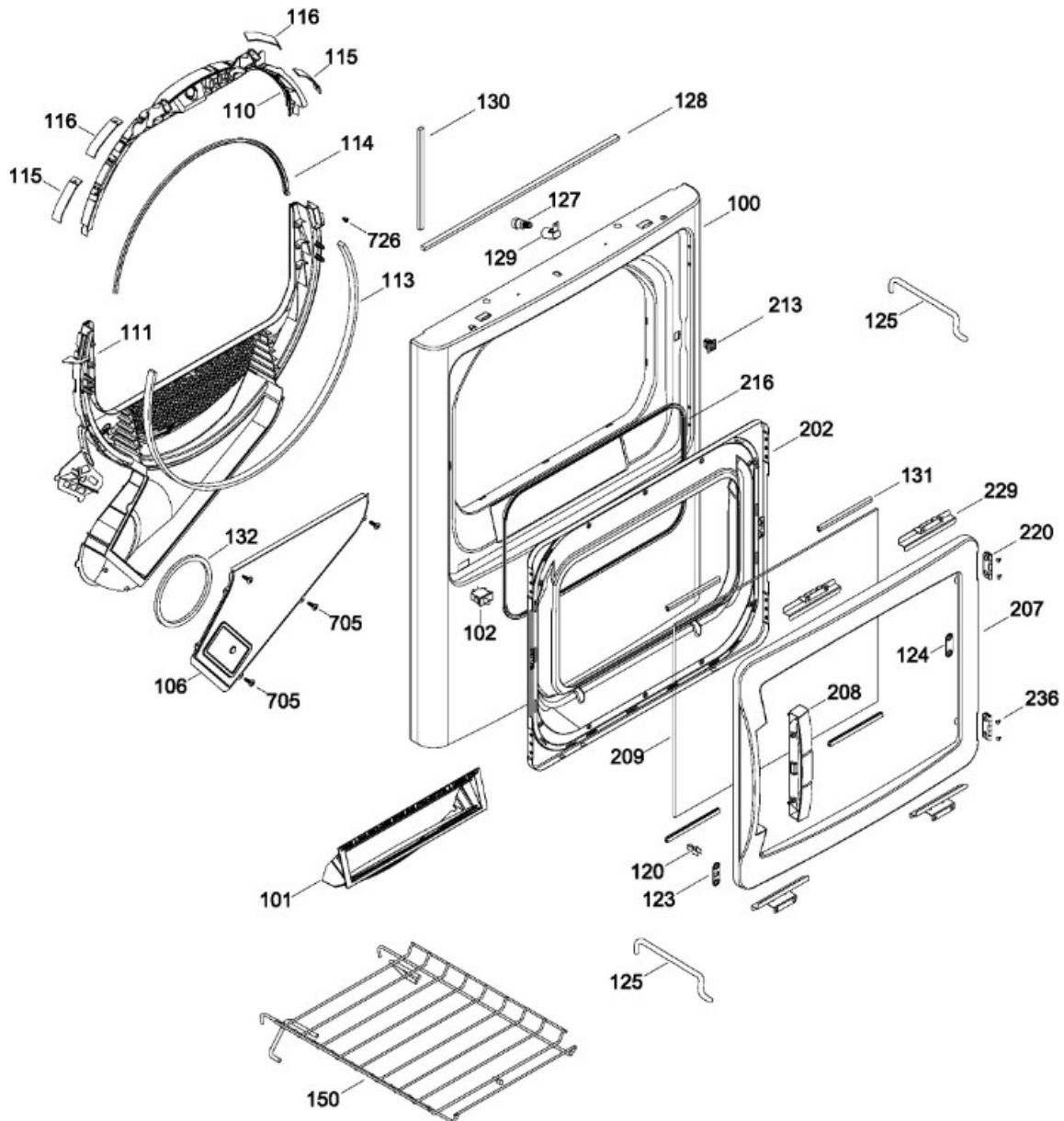

GABINETE

SEL1545PXPB0

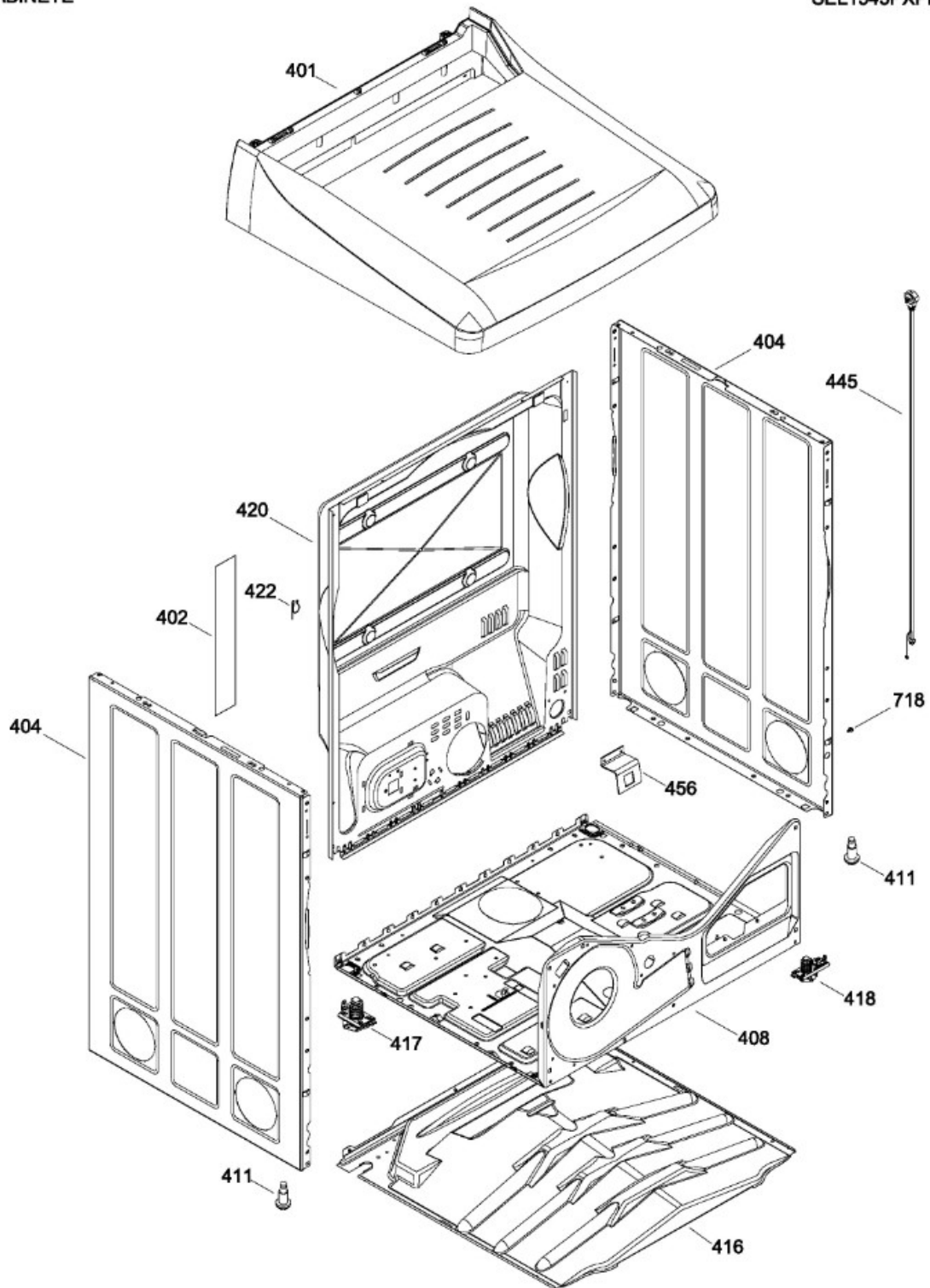

SISTEMA DE TRANSMISION / BLOWER & DRIVE ASSEMBLY

SEL1545PXPB0

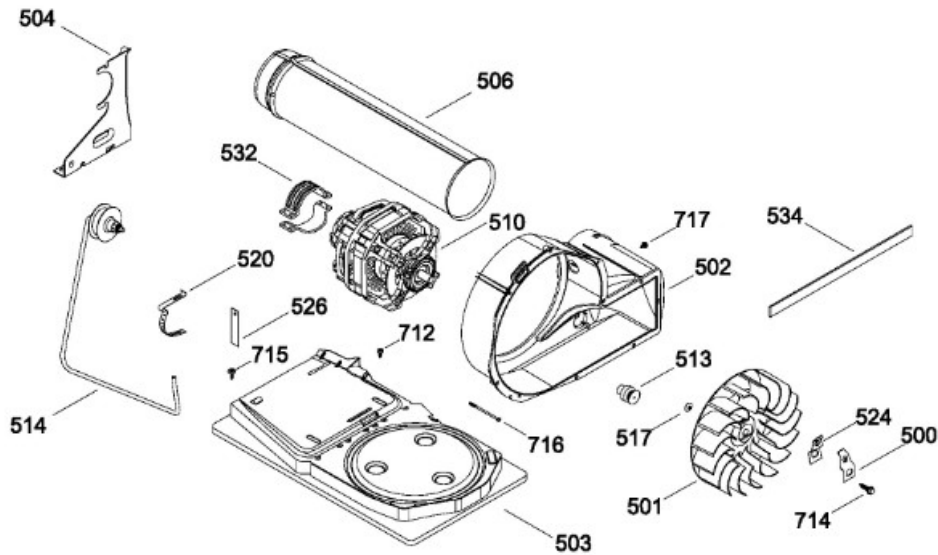

QUEMADOR / BURNER

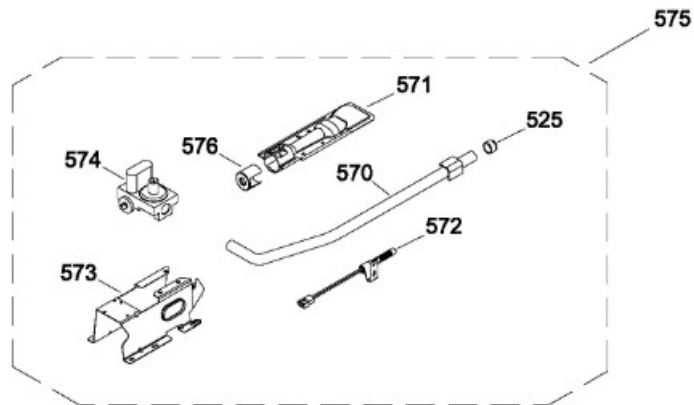

TAMBOR

SEL1545PXPB0

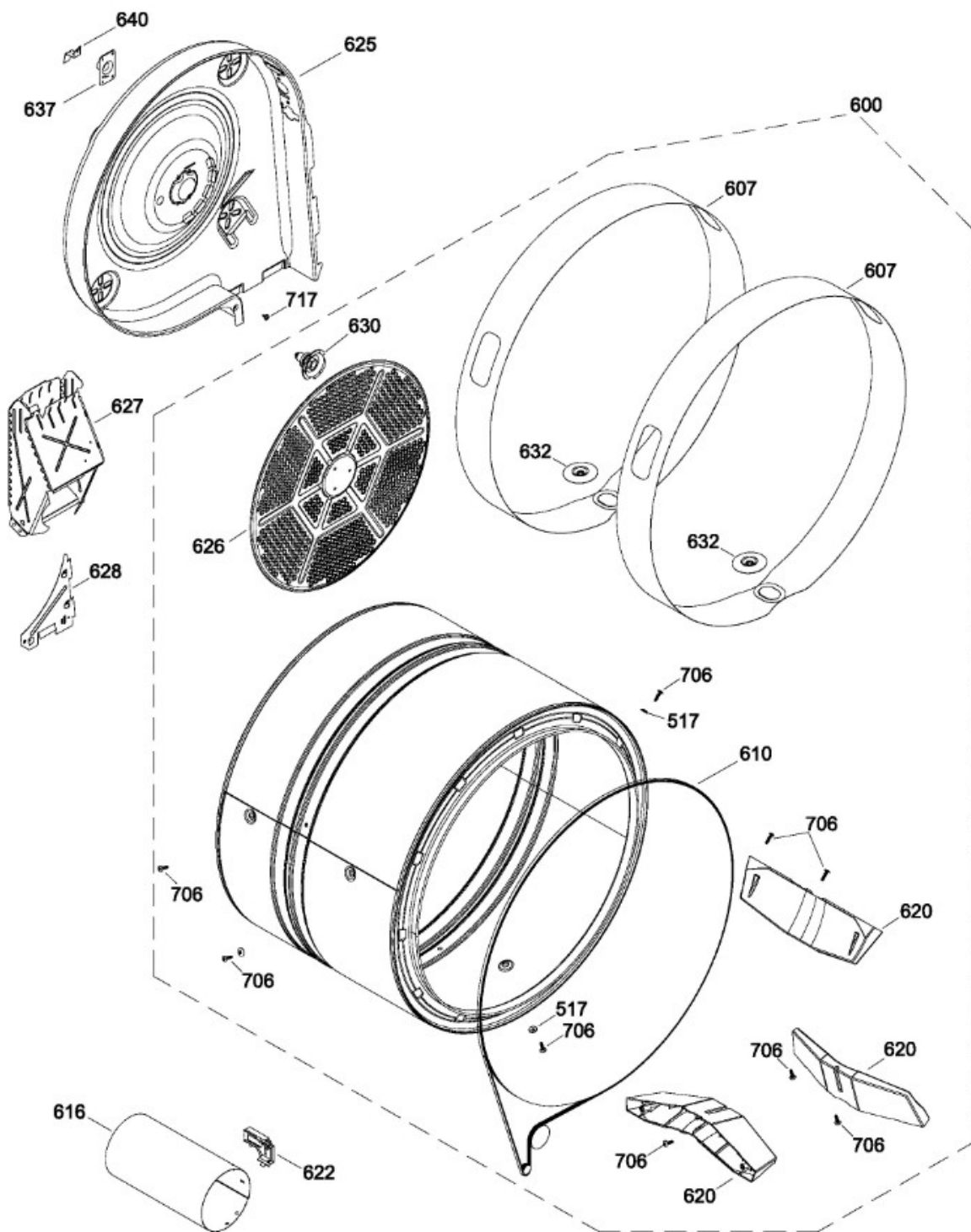

Guía	Refacción	Descripción
1	189D7005G002F	COPETE Y GRAFICOS ENS(GRIS)
7	WW02L00115	PERILLA ROTATORIA ENS
8	WW02L00118	PERILLA CONTROL ENS
9	WW02A00063	GUIA LUZ
11	WW02F00087	CUBIERTA DISPLAY
12	WW01L00419	LOGO EASY
15	WW02F00043	ENS. ARNES
19	WW02L00136	BOTON INICIO
20	WW02L00137	BUJE PARA PEILLA
29	WW02A00042	JUMPER GAS
31	WW02F00034	ENS. TARJETA CIRCUITO IMPRESO
100	WW02L00049	PANEL FRONTAL
101	WW02L00080	ENS. FILTRO MALLA
101	WW02F00616	ENS. FILTRO MALLA
102	WW02L00025	INTERRUPTOR PUERTA
106	WW02L00061	CUBIERTA DUCTO
110	WW02F00010	COJINETE SUP.
110	WW01L01430	COJINETE SUP.
111	WW02F00178	TRAMPA CONDUCTO
111	WW02L00103	TRAMPA CONDUCTO
111	WW02F00600	DUCTO
113	WW02L00139	FIELTRO
113	WW02L00138	FIELTRO
114	WW02L00145	SELLO PUERTA
115	WW02A00033	BEARING_SLIDE
116	WW02L00038	BEARING_SLIDE
118	WW02F00094	ARNES SENS.OR
120	WW02A00004	STRIKE
123	WW02A00056	STRIKE PLATE
124	WW02A00057	STRIKE PLATE
125	WW02F00088	SENSOR ROD
127	WW02A00067	LAMP
127	WW03F00458	LAMP
127	WW03F00458	LAMPARA
127	WW03F00458	LAMPARA
128	WW02L00041	SELLO
129	WW02L00104	ENS. CLAVIJA

Guía	Refacción	Descripción
129	WW01F01584	ENS. CLAVIJA
130	WW02L00042	SELLO
131	WW02L00102	RETAINER GASKET
132	WW02L00039	SELLO
132	WW03F00354	SELLO
150	WW02L00088	SHOE RACK
150	WW02L00190	SHOE RACK
202	WW02L00052	PUERTA INTERIOR
202	WW02L00052	PUERTA INTERIOR
202	WW02L00052	PUERTA INTERIOR(BLANCA)
207	WW02F00032	ANILLO EXT.
208	WW02L00056	JALADERA
208	WW02L00055	JALADERA
209	WW02L00058	PANEL VIDRIO
213	WW02L00037	LATCH ASM.
216	WW02L00062	SELLO VENTANA
220	WW02L00029	BISAGRA
220	WW02L00028	BISAGRA
229	WW02L00101	SOPORTE VIDRIO
229	WW02L00101	SOPORTE VIDRIO
229	WW02L00101	SOPORTE VIDRIO
236	WW02A00065	BOTON BELLEZA
401	WW02A00043	CUBIERTA SECADORA
401	WW02A00043	CUBIERTA SECADORA
401	WW02A00043	CUBIERTA PLASTICA
402	WW02L00147	DAMPENING PLATE
404	WW02L00206	LATERAL ESTUFA
408	WW02F00076	BASTIDOR BASE
411	WW02L00142	PATA ESTABILIZADORA ENS.
416	WW02A00045	DEFLECTOR
416	WW02A00045	DEFLECTOR
416	WW02A00045	DEFLECTOR DE CALOR
417	WW02A00059	ENS. SOPORTE POST.
418	WW02L00108	ENS. SOPORTE FRONT.
420	WW02L00146	PANEL POST.
422	WW02F00022	CORD SET RETAINER
445	WW02F00091	CABLE TOMACORRIENTE

Guía	Refacción	Descripción
456	WW02A00037	BRIDE
500	WW02A00040	ABRAZADERA VENTILADOR
501	WW02A00073	VENTILADOR REDONDO
502	WW02F00109	BLOWER HOUSING
502	WW03L00150	BLOWER HOUSING
503	WW02F00098	PLATO MOTOR
504	WW02F00027	SOPORTE MOTOR
506	572D559P006	CONDUCTO DE ESCAPE
510	WW02F00186	ENS. MOTOR
510	WW02A00191	ENS. MOTOR
514	WW02A00008	ENS. BRAZO AUXILIAR
514	WW03F00350	ENS. BRAZO AUXILIAR
517	WW02A00002	ARANDELA
520	WW02F00031	CLIP MOTOR
524	WW02A00041	ABRAZADERA VENTILADOR
525	WW02A00003	TAPA
526	WW02L00033	ESPACIADOR ESPUMADO
532	WW02F00003	CORREA MOTOR
532	WW02A00232	CORREA MOTOR
534	WW02A00026	EMPAQUE ESCAPE SOPLADOR
534	WW02F00785	EMPAQUE ESCAPE SOPLADOR
570	WW02A00058	PIPE & LUG ASM.
570	WW03F00137	PIPE & LUG ASM.
571	WW02A00020	QUEMADORES
572	WW02F00002	ALLUME-GAZ
572	WW02F00740	ALLUME-GAZ
572	WW01F01432	ENCENDEDOR INCANDESCENTE
573	WW02F00077	GAS VALVE BRACKET
573	WW03A00125	GAS VALVE BRACKET
574	WW02F00095	VALVUAL DE GAS ENS.
575	WW02F00080	VALVULA Y QUEMADOR ENS
576	WW02L00140	AIRADOR
600	WW02F00057	ENS. TAMBOR
607	WW02L00098	BANDA TAMBOR
610	WW02F00028	BANDA SECADORA
610	WW02F00854	BANDA SECADORA
616	WW03F00345	TUBO DE COMBUSTION



Guía	Refacción	Descripción
620	WW02L00143	BAFFLE
622	WW02F00001	DETECTOR TERMOSTATO
625	WW02L00014	DIFUSOR GAS
625	WW03F00095	DIFUSOR GAS
626	WW02F00030	DIFUSOR
627	WW02F00097	DUCTO DE TRANSICION
628	WW02F00029	DIFUSSER PLATE
630	WW02A00019	SOPORTE Y FLECHA ENSAMBLE
632	WW02A00072	RONDANDA BANDA
637	WW02A00005	RETENEDOR RODAMIENTO
640	WW02F00026	GROUND STRAP ASM.
640	WW01A00443	GROUND STRAP ASM.
640	WW02F00833	GROUND STRAP ASSEMBLY
705	WW02A00028	TORNILLO
706	WW02A00031	TORNILLO
712	WW02A00029	TORNILLO
712	WW02A00211	TORNILLO
714	WW02A00071	TORNILLO
715	WW02A00070	TORNILLO
716	WW02A00032	TORNILLO
717	WW02A00030	TORNILLO
717	WW02A00211	TORNILLO
718	WW01A00001	TORNILLO
726	WW02A00027	SCREW