

Distribuidor Autorizado

SurteRápido.com

Venta de Refacciones
Electrodomesticas

SECADORA SGL1445JMSBB0

SISTEMA CONTROLES

SGL1445JMSBB0

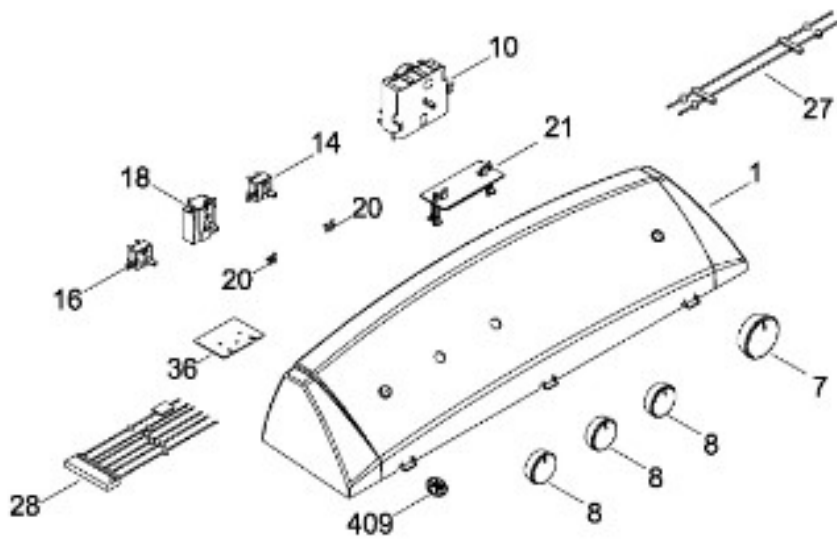

Distribuidor Autorizado

SurteRápido.com

Venta de Refacciones
Electrodomesticas

SECADORA SGL1445JMSBB0

PUERTA (ENS)

SGL1445JMSBB0

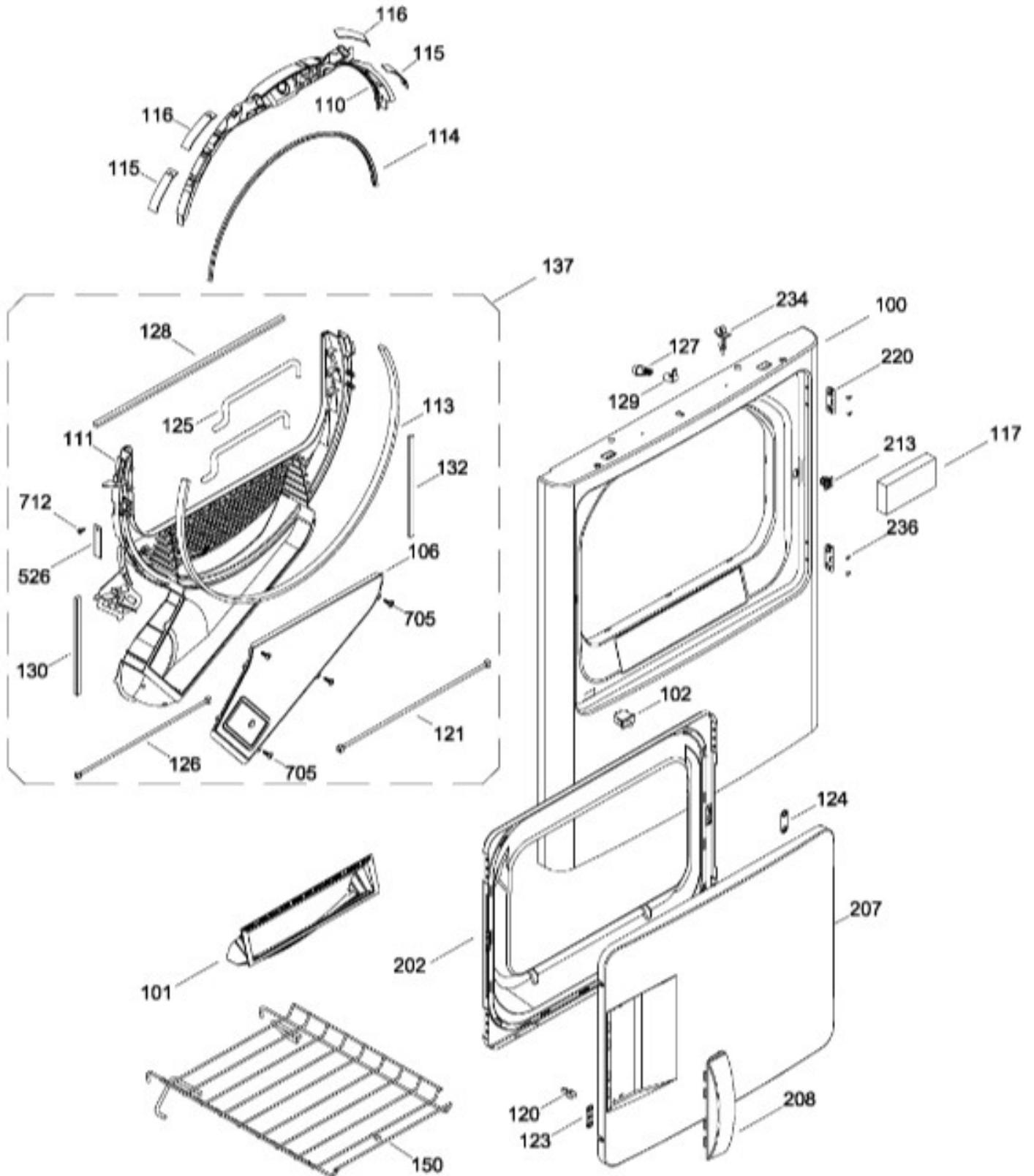

Distribuidor Autorizado

SurteRápido.com

Venta de Refacciones
Electrodomesticas

SECADORA SGL1445JMSBB0

GABINETE

SGL1445JMSBB0

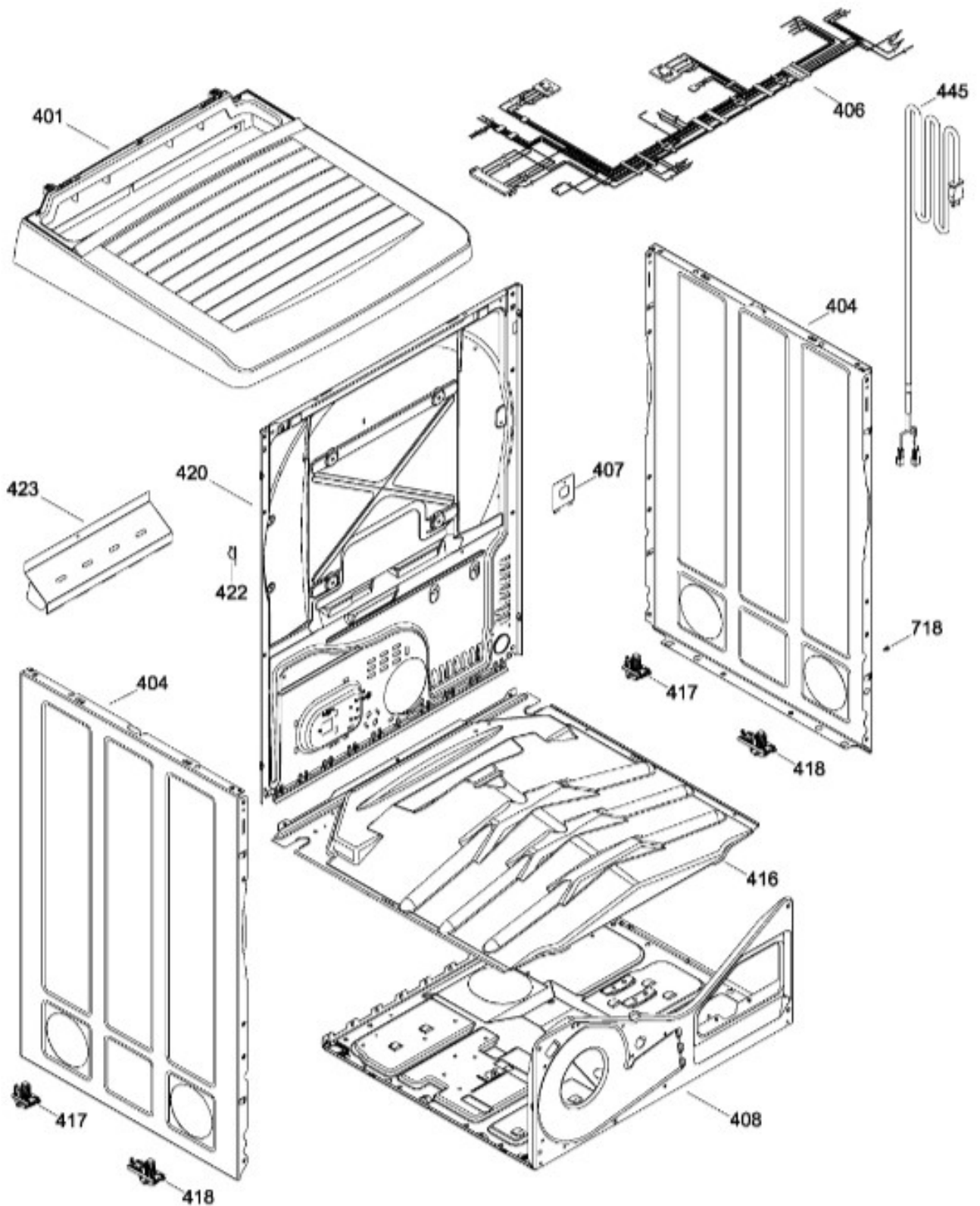

Distribuidor Autorizado

SurteRápido.com

Venta de Refacciones
Electrodomesticas

SECADORA SGL1445JMSBB0

SISTEMA DE TRANSMISION / BLOWER & DRIVE ASSEMBLY

SGL1445JMSBB0

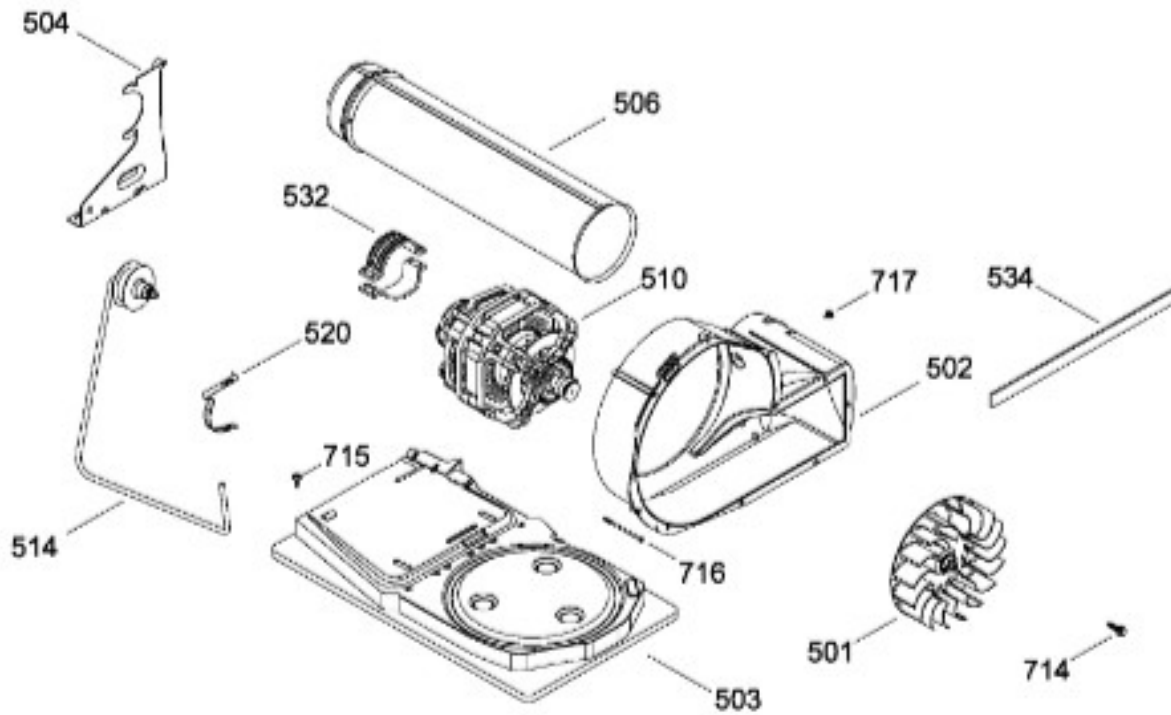

Distribuidor Autorizado

SurteRápido.com

Venta de Refacciones
Electrodomesticas

SECADORA SGL1445JMSBB0

Guía	Refacción	Descripción
1	WW02L00077	ENS. COPETE GRAFICOS
7	WW02L00117	ENS. PERILLA CONTROL
8	WW02L00113	PERILLA ROTATORIA
10	212D1233P020	RELOJ
14	WW02L00081	INTERRUPTOR ROTATORIO
16	WW02L00083	INTERRUPTOR DE INICIO
18	WW02L00086	INTERRUPTOR ROTATORIO
20	WW02L00137	BUJE PARA PEILLA
21	WW02F00090	RESISTENCIA ENS.
27	WW02F00218	ARNES PANEL CONTROL
28	WW02F00219	ARNES PCB
36	WW02F00092	TARJETA PC
100	WW02L00049	PANEL FRONTAL
101	WW02L00080	ENS. FILTRO MALLA
101	WW02F00616	ENS. FILTRO MALLA
102	WW02L00025	INTERRUPTOR PUERTA
106	WW02L00061	CUBIERTA DUCTO
110	WW02F00010	COJINETE SUP.
110	WW01L01430	COJINETE SUP.
111	WW02F00178	TRAMPA CONDUCTO
111	WW02L00103	TRAMPA CONDUCTO
111	WW02F00600	DUCTO
113	WW02L00139	FIELTRO
113	WW02L00138	FIELTRO
114	WW02L00145	SELLO PUERTA
115	WW02A00033	BEARING_SLIDE
116	WW02L00038	BEARING_SLIDE
117	WW02A00025	ESPACIADOR DE PUERTA SOLIDA
120	WW02A00004	STRIKE
121	WW02A00051	ARNES
123	WW02A00056	STRIKE PLATE
124	WW02A00057	STRIKE PLATE
125	WW02F00088	SENSOR ROD
126	WW02A00052	ARNES
127	WW02A00067	LAMP

Distribuidor Autorizado

SurteRápido.com

Venta de Refacciones
Electrodomesticas

SECADORA SGL1445JMSBB0

Guía	Refacción	Descripción
127	WW03F00458	LAMP
127	WW03F00458	LAMPARA
128	WW02L00041	SELLO
129	WW02L00104	ENS. CLAVIJA
129	WW01F01584	ENS. CLAVIJA
130	WW02L00042	SELLO
132	WW02L00039	SELLO
132	WW03F00354	SELLO
137	WW02F00128	DUCTO TRAMPA ENS CON SENSORES
137	WW02F00599	DUCTO TRAMPA ENS CON SENSORES
150	WW02L00088	SHOE RACK
150	WW02L00190	SHOE RACK
202	WW02L00053	INNER DOOR
207	WW02L00051	PUERTA EXTERIOR
207	WW02L00051	PUERTA EXTERIOR
207	WW02L00051	PUERTA EXTERIOR
208	WW02L00016	JALADERA PUERTA(BCO)
213	WW02L00037	LATCH ASM.
220	WW02L00029	BISAGRA
220	WW02L00028	BISAGRA
234	WW02A00036	LIBERADOR TENS.IONES
236	WW02A00065	BOTON BELLEZA
401	WW02L00073	CUBIERTA
404	WW02L00149	PANEL LATERAL
404	WW02L00149	PANEL LATERAL
404	WW02L00149	PANEL LATERAL
406	WW02F00220	ARNES ENSAMBLE ELECT
407	WW02L00141	CUBIERTA
408	WW02F00076	BASTIDOR BASE
409	WW01L00421	LOGO GE
416	WW02A00045	DEFLECTOR
416	WW02A00045	DEFLECTOR
416	WW02A00045	DEFLECTOR DE CALOR
417	WW02A00059	ENS. SOPORTE POST.
418	WW02L00108	ENS. SOPORTE FRONT.

Distribuidor Autorizado

SurteRápido.com

Venta de Refacciones
Electrodomesticas

SECADORA SGL1445JMSBB0

Guía	Refacción	Descripción
420	WW02L00144	PANEL POST.
422	WW02F00022	CORD SET RETAINER
423	WW02L00107	ESCUDO CALOR POST.
445	WW02F00082	CORDON TOMACORRIENTE
501	WW02A00011	SOPLADOR PUERTA
501	WW01F01162	SOPLADOR PUERTA
502	WW02A00012	CARCAZA ASPAS
502	WW02L00013	CARCAZA ASPAS
502	WW02L00433	CAJA DEL VENTILADOR
503	WW02F00098	PLATO MOTOR
504	WW02F00027	SOPORTE MOTOR
506	572D559P006	CONDUCTO DE ESCAPE
510	WW02F00062	MOTOR
514	WW02A00008	ENS. BRAZO AUXILIAR
514	WW03F00350	ENS. BRAZO AUXILIAR
517	WW02A00002	ARANDELA
520	WW02F00031	CLIP MOTOR
526	WW02L00033	ESPACIADOR ESPUMADO
532	WW02F00003	CORREA MOTOR
532	WW02A00232	CORREA MOTOR
534	WW02A00026	EMPAQUE ESCAPE SOPLADOR
534	WW02F00785	EMPAQUE ESCAPE SOPLADOR
600	WW02F00056	ENS. TAMBOR
610	WW02F00028	BANDA SECADORA
610	WW02F00854	BANDA SECADORA
620	WW02L00143	BAFFLE
623	WW02F00050	ARNES
626	WW02F00030	DIFUSOR
630	WW02A00019	SOPORTE Y FLECHA ENSAMBLE
635	WW02A00050	ENS. CALENTADOR
635	WW02A00050	ENS. CALENTADOR
635	WW02A00050	CALENTADOR ENSAMBLE
635	WW02A00050	ENS. CALENTADOR
637	WW02A00005	RETENEDOR RODAMIENTO
640	WW02F00026	GROUND STRAP ASM.

Distribuidor Autorizado

SurteRápido.com

Venta de Refacciones
Electrodomesticas

SECADORA SGL1445JMSBB0

Guía	Refacción	Descripción
640	WW01A00443	GROUND STRAP ASM.
640	WW02F00833	GROUND STRAP ASSEMBLY
705	WW02A00028	TORNILLO
706	WW02A00031	TORNILLO
712	WW02A00029	TORNILLO
712	WW02A00211	TORNILLO
714	WW02A00071	TORNILLO
715	WW02A00070	TORNILLO
716	WW02A00032	TORNILLO
717	WW02A00030	TORNILLO
717	WW02A00211	TORNILLO
718	WW01A00001	TORNILLO
725	WW02A00069	SCREW