

Distribuidor Autorizado

SurteRápido.com

Venta de Refacciones  
Electrodomesticas

# SECADORA SGL1545ESWS0

SISTEMA CONTROLES

SGL15405ESGG0  
SGL1545ESWS0

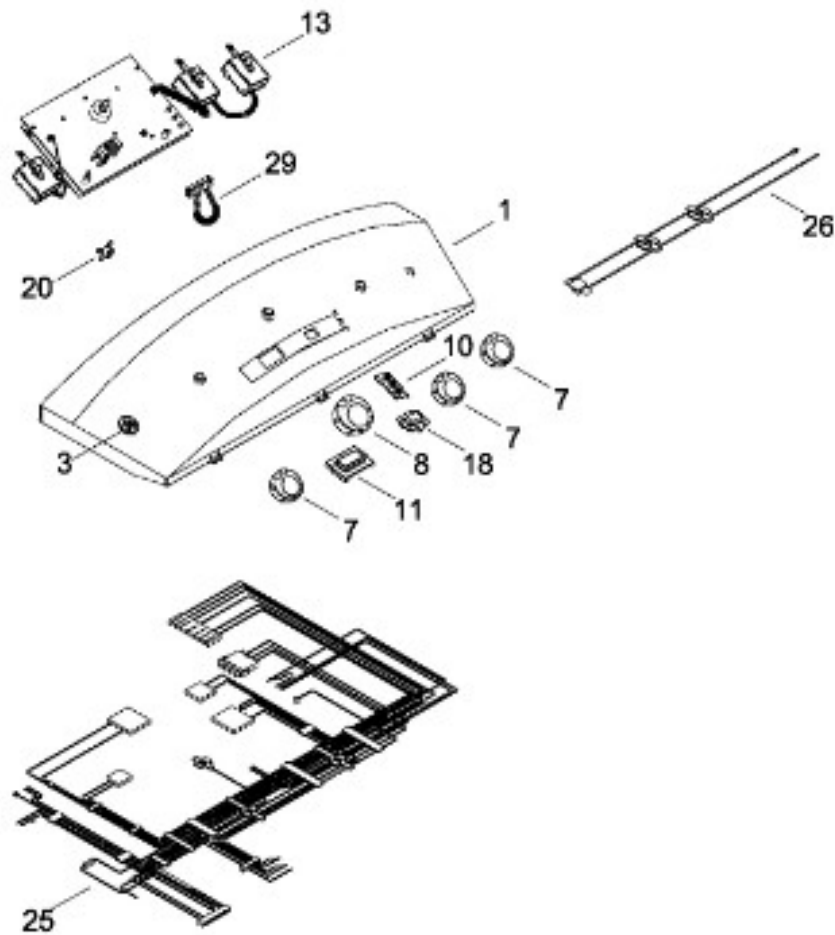

Distribuidor Autorizado

SurteRápido.com

Venta de Refacciones  
Electrodomesticas

# SECADORA SGL1545ESWS0

PUERTA (ENS)

SGL15405ESGG0  
SGL1545ESWS0

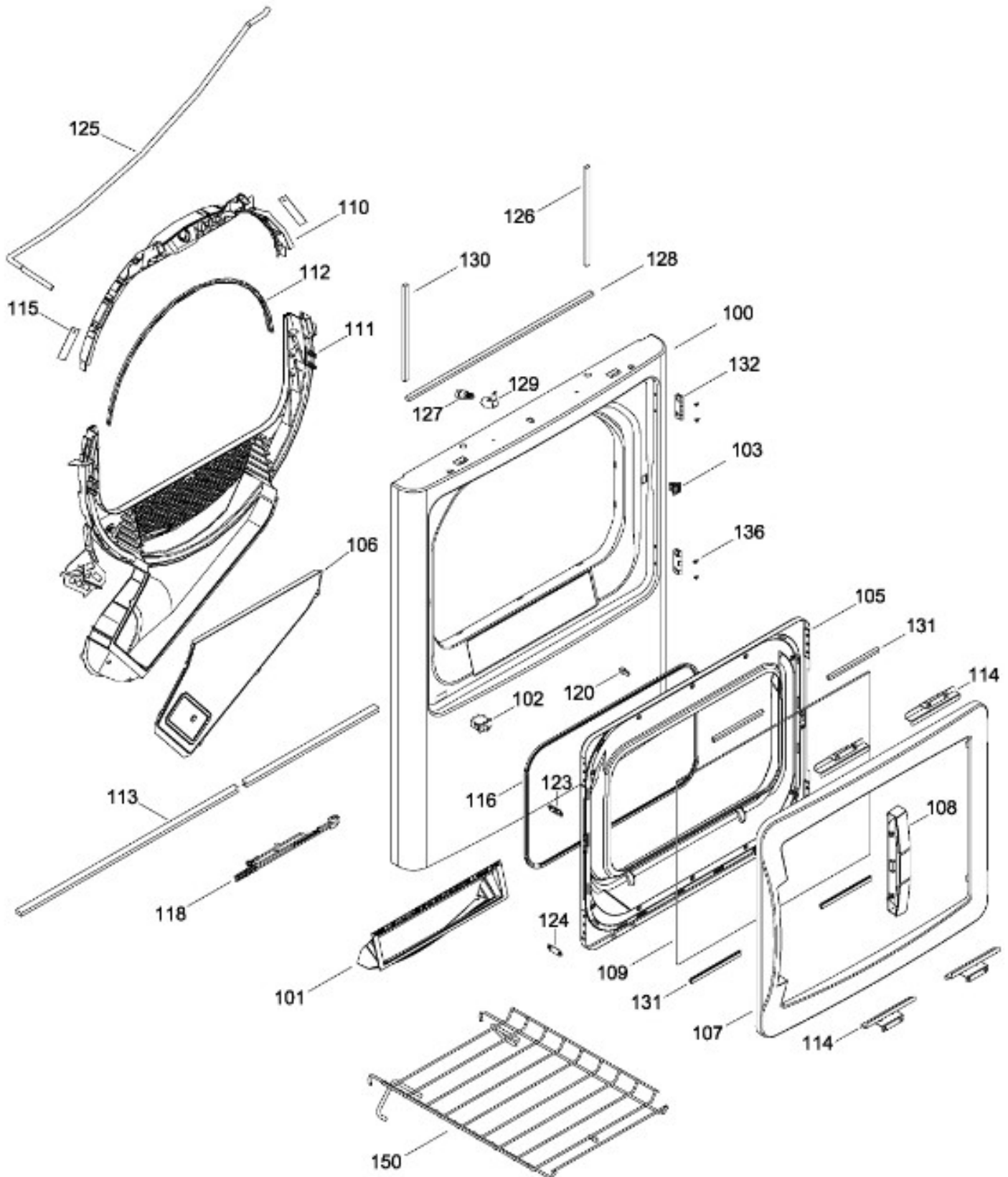

Distribuidor Autorizado

SurteRápido.com

Venta de Refacciones  
Electrodomesticas

# SECADORA SGL1545ESWS0

SISTEMA DE TRANSMISION / BLOWER & DRIVE ASSEMBLY

SGL15405ESGG0  
SGL1545ESWS0

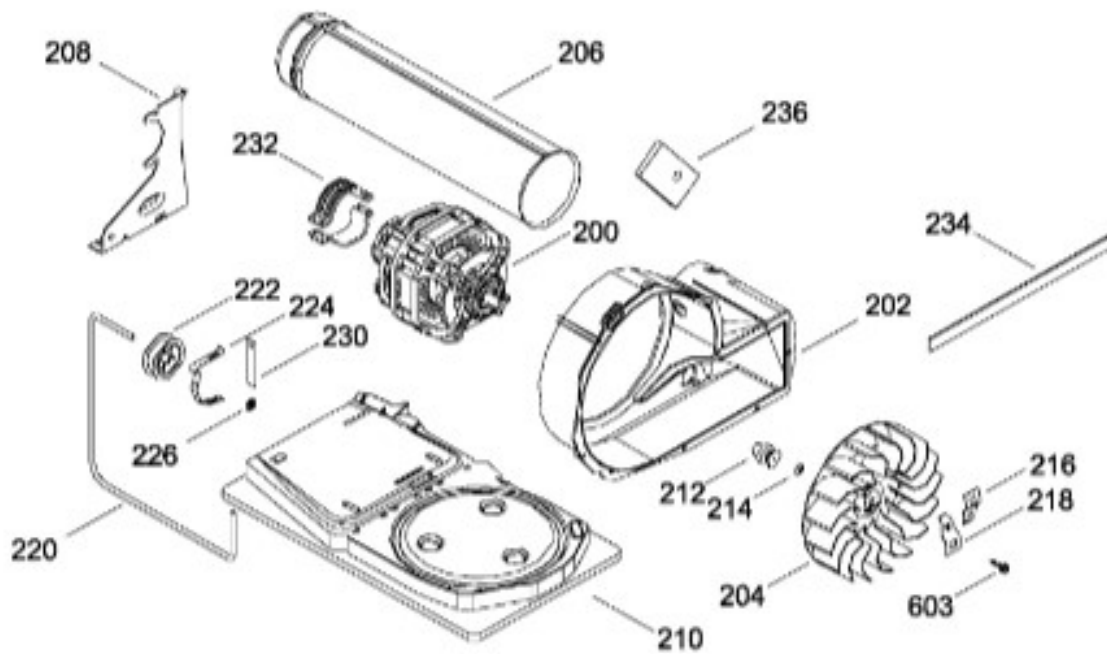

Distribuidor Autorizado

SurteRápido.com

Venta de Refacciones  
Electrodomesticas

# SECADORA SGL1545ESWS0

GABINETE

SGL15405ESGG0  
SGL1545ESWS0

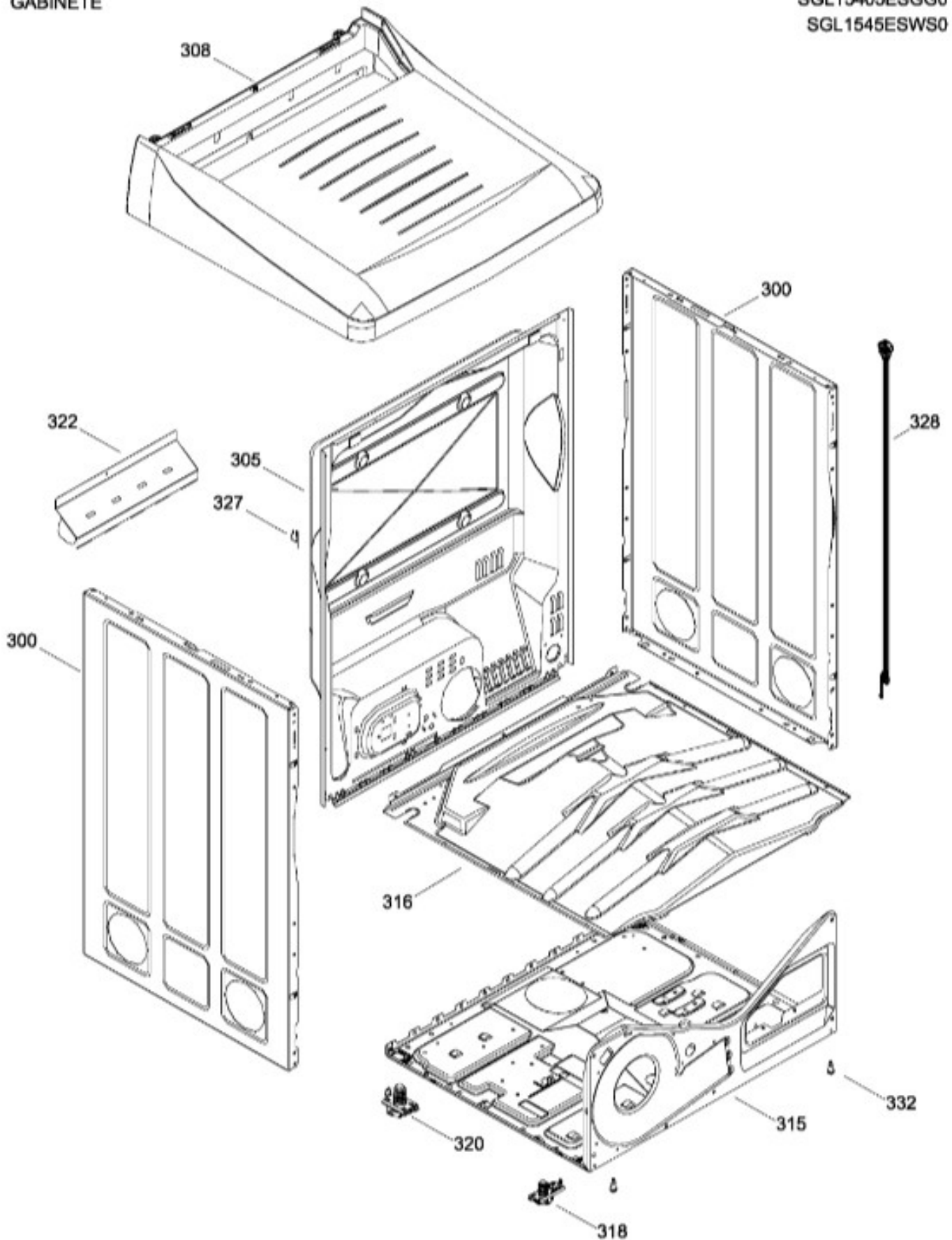

Distribuidor Autorizado

SurteRápido.com

Venta de Refacciones  
Electrodomesticas

# SECADORA SGL1545ESWS0

TAMBOR

SGL15405ESGG0  
SGL1545ESWS0

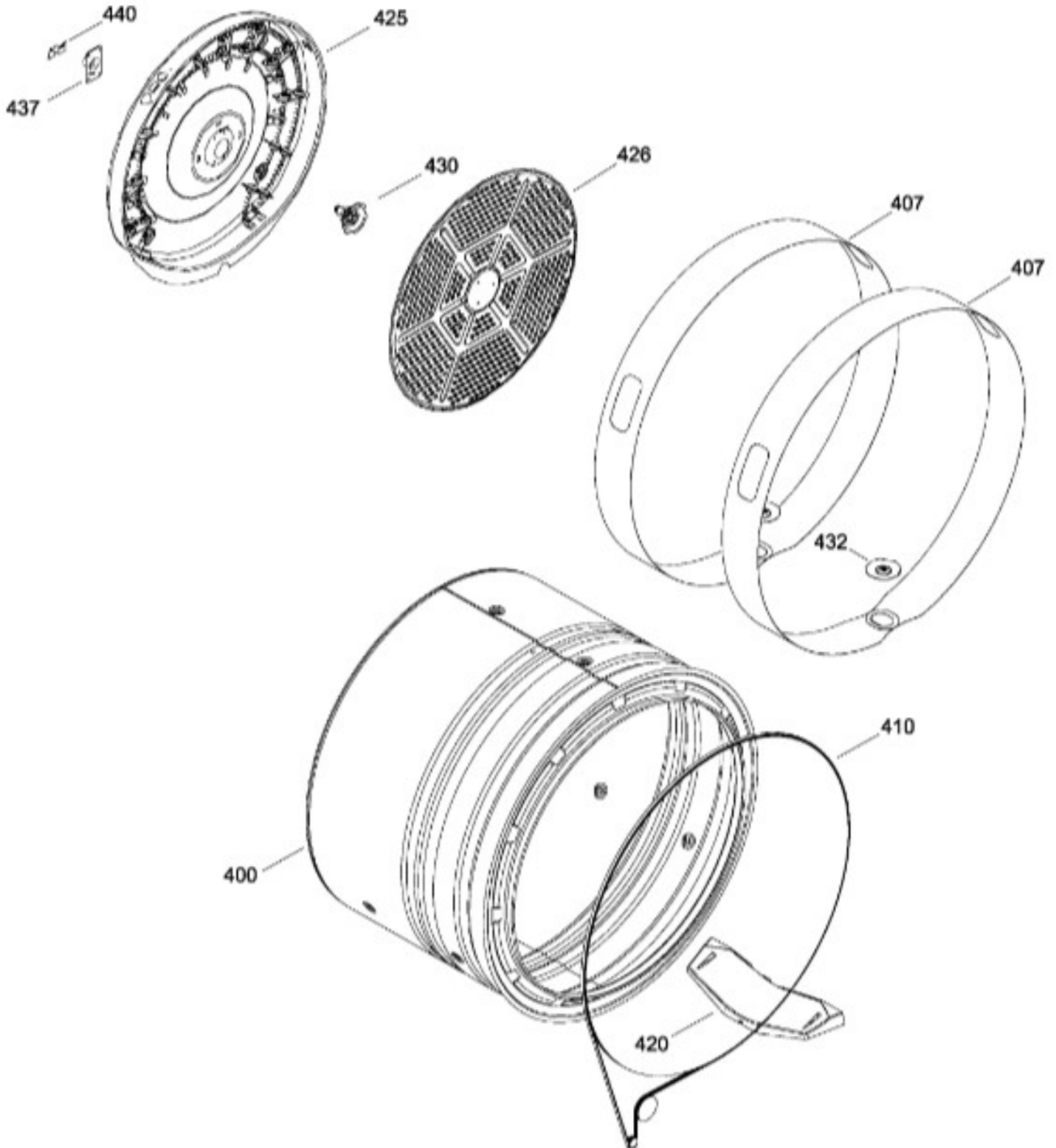

Distribuidor Autorizado

**SurteRápido.com**

Venta de Refacciones  
Electrodomesticas

## SECADORA SGL1545ESWS0

Guía	Refacción	Descripción
1	WW02F00106	DISIPADOR COPETE
1	WW02L00069	DISIPADOR COPETE
3	WW01L00421	LOGO GE
7	WW02L00131	ENS. PERILLA ROTATORIA
8	WW02L00126	ENS. PERILLA CONTROL
10	WW02A00063	GUIA LUZ
11	WW02F00087	CUBIERTA DISPLAY
13	WW02F00034	ENS. TARJETA CIRCUITO IMPRESO
18	WW02L00136	BOTON INICIO
20	WW02L00137	BUJE PARA PEILLA
25	WW02F00134	ENS. ARNES
25	WW02F00451	ENS. ARNES
26	WW02F00136	ARNES
29	WW02A00091	JUMPER ELECTRIC
100	WW02L00049	PANEL FRONTAL
101	WW02L00080	ENS. FILTRO MALLA
101	WW02F00616	ENS. FILTRO MALLA
102	WW02L00025	INTERRUPTOR PUERTA
103	WW02L00037	LATCH ASM.
105	WW02L00052	PUERTA INTERIOR
105	WW02L00052	PUERTA INTERIOR
105	WW02L00052	PUERTA INTERIOR(BLANCA)
106	WW02L00061	CUBIERTA DUCTO
107	WW02F00032	ANILLO EXT.
108	WW02L00056	JALADERA
108	WW02L00055	JALADERA
109	WW02L00058	PANEL VIDRIO
110	WW02F00010	COJINETE SUP.
110	WW01L01430	COJINETE SUP.
111	WW02F00178	TRAMPA CONDUCTO
111	WW02L00103	TRAMPA CONDUCTO
111	WW02F00600	DUCTO
112	WW02L00145	SELLO PUERTA
113	WW02L00139	FIELTRO
113	WW02L00138	FIELTRO

Distribuidor Autorizado

**SurteRápido.com**

Venta de Refacciones  
Electrodomesticas

## SECADORA SGL1545ESWS0

Guía	Refacción	Descripción
114	WW02L00101	SOPORTE VIDRIO
114	WW02L00101	SOPORTE VIDRIO
114	WW02L00101	SOPORTE VIDRIO
115	WW02A00033	BEARING_SLIDE
116	WW02L00062	SELLO VENTANA
118	WW02F00094	ARNES SENS.OR
120	WW02A00004	STRIKE
123	WW02A00056	STRIKE PLATE
124	WW02A00057	STRIKE PLATE
125	WW02F00088	SENSOR ROD
126	WW02L00039	SELLO
126	WW03F00354	SELLO
127	WW02A00067	LAMP
127	WW03F00458	LAMP
127	WW03F00458	LAMPARA
128	WW02L00041	SELLO
129	WW02L00104	ENS. CLAVIJA
129	WW01F01584	ENS. CLAVIJA
130	WW02L00042	SELLO
131	WW02L00102	RETAINER GASKET
132	WW02L00029	BISAGRA
132	WW02L00028	BISAGRA
136	WW02A00065	BOTON BELLEZA
150	WW02L00088	SHOE RACK
150	WW02L00190	SHOE RACK
200	WW02F00186	ENS. MOTOR
200	WW02A00191	ENS. MOTOR
202	WW02F00109	BLOWER HOUSING
202	WW03L00150	BLOWER HOUSING
204	WW02A00073	VENTILADOR REDONDO
206	572D559P006	CONDUCTO DE ESCAPE
208	WW02F00027	SOPORTE MOTOR
210	WW02F00098	PLATO MOTOR
214	WW02A00002	ARANDELA
216	WW02A00038	VENTILADOR

Distribuidor Autorizado

**SurteRápido.com**

Venta de Refacciones  
Electrodomesticas

## SECADORA SGL1545ESWS0

Guía	Refacción	Descripción
216	WW02A00040	VENTILADOR
218	WW02A00039	VENTILADOR
218	WW02A00041	VENTILADOR
220	WW02A00060	BRAZO TENS.OR
220	WW03L00340	BRAZO TENS.OR
222	WW02L00151	POLEA
222	WW02F00871	POLEA
224	WW02F00031	CLIP MOTOR
226	WW02A00034	TAPA TUERCA
230	WW02L00033	ESPACIADOR ESPUMADO
232	WW02F00003	CORREA MOTOR
232	WW02A00232	CORREA MOTOR
234	WW02A00026	EMPAQUE ESCAPE SOPLADOR
234	WW02F00785	EMPAQUE ESCAPE SOPLADOR
236	WW02L00038	BEARING_SLIDE
300	WW02L00206	LATERAL ESTUFA
305	WW02L00146	PANEL POST.
308	WW02A00043	CUBIERTA SECADORA
308	WW02A00043	CUBIERTA SECADORA
308	WW02A00043	CUBIERTA PLASTICA
315	WW02F00076	BASTIDOR BASE
316	WW02A00045	DEFLECTOR
316	WW02A00045	DEFLECTOR
316	WW02A00045	DEFLECTOR DE CALOR
318	WW02L00108	ENS. SOPORTE FRONT.
320	WW02A00059	ENS. SOPORTE POST.
322	WW02L00107	ESCUDO CALOR POST.
327	WW02F00022	CORD SET RETAINER
328	WW02F00016	CORDON TOMACORRIENTE
407	WW02L00098	BANDA TAMBOR
410	WW02F00028	BANDA SECADORA
410	WW02F00854	BANDA SECADORA
420	WW02L00143	BAFFLE
425	WW02A00049	ENS. CALENTADOR
425	WW02A00049	ENS. CALENTADOR



Distribuidor Autorizado

**SurteRápido.com**

Venta de Refacciones  
Electrodomesticas

## SECADORA SGL1545ESWS0

Guía	Refacción	Descripción
426	WW02F00030	DIFUSOR
430	WW02A00019	SOPORTE Y FLECHA ENSAMBLE
432	WW02A00072	RONDANDA BANDA
437	WW02A00005	RETENEDOR RODAMIENTO
440	WW02F00026	GROUND STRAP ASM.
440	WW01A00443	GROUND STRAP ASM.
440	WW02F00833	GROUND STRAP ASSEMBLY
603	WW02A00071	TORNILLO