

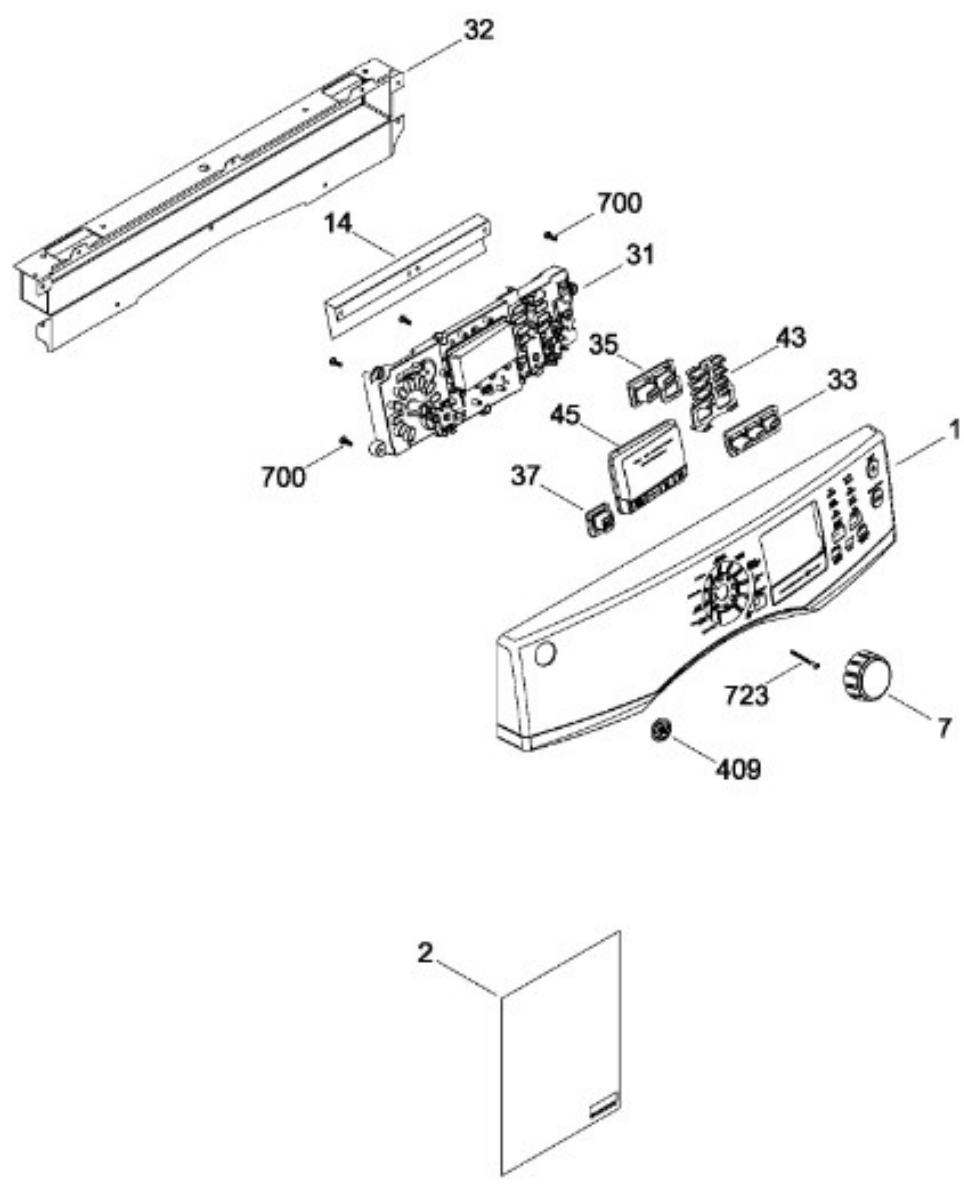

SECADORA SGW819SDGCW01

SISTEMA CONTROLES / CONTROL SYSTEM

SGW819SDGCG01
SGW819SDGCW01



BENITO JUÁREZ #1500 GPE ZITON, CD. GUADALUPE NUEVO LEÓN TEL: 8183377999 Y 49
HORARIOS: LUNES A VIERNES 8:30 A 6:00 PM Y SÁBADOS DE 8:30 A 2:00 PM
WEB: www.denek.com



SECADORA SGW819SDGCW01

PANEL FRONTAL (ENS) / FRONT PANEL (ASM)

SGW819SDGCG01
SGW819SDGCW01

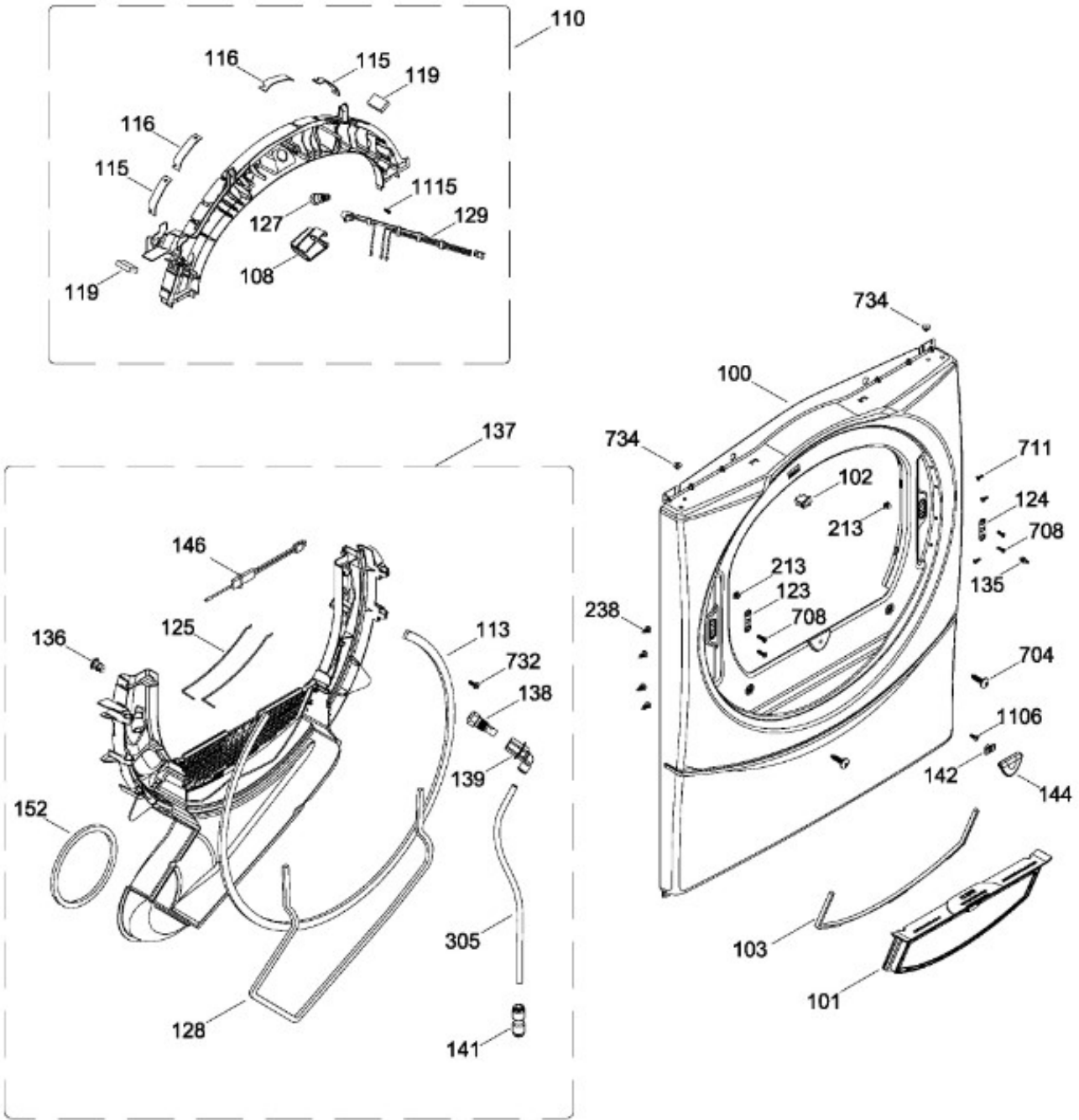

BENITO JUÁREZ #1500 GPE ZITON, CD. GUADALUPE NUEVO LEÓN TEL: 8183377999 Y 49
HORARIOS: LUNES A VIERNES 8:30 A 6:00 PM Y SÁBADOS DE 8:30 A 2:00 PM
WEB: www.denek.com



SECADORA SGW819SDGCW01

PUERTA (ENS) / DOOR (ASM)

SGW819SDGCG01
SGW819SDGCW01

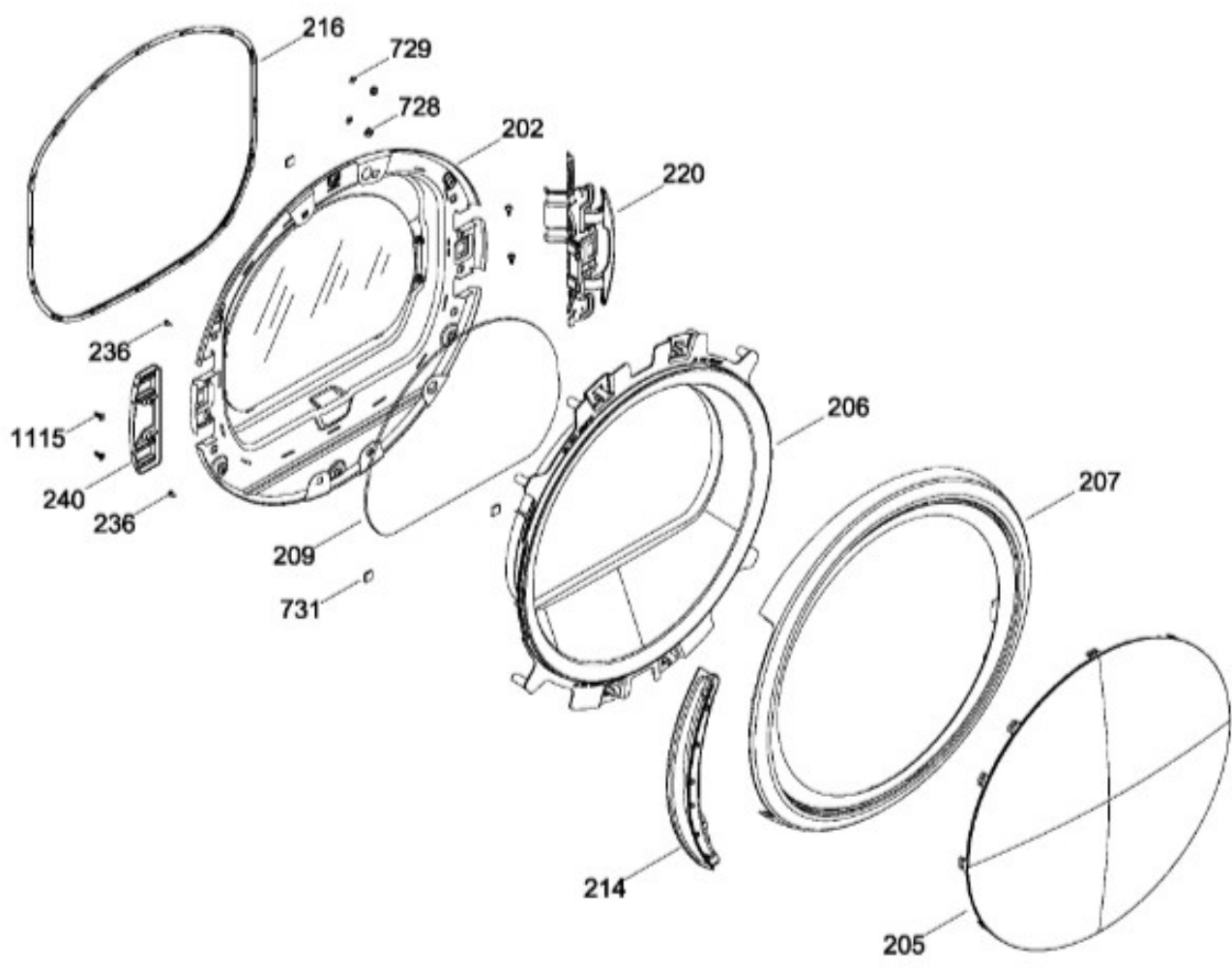

BENITO JUÁREZ #1500 GPE ZITON, CD. GUADALUPE NUEVO LEÓN TEL: 8183377999 Y 49
 HORARIOS: LUNES A VIERNES 8:30 A 6:00 PM Y SÁBADOS DE 8:30 A 2:00 PM
 WEB: www.denek.com



SECADORA SGW819SDGCW01

GABINETE / STRUCTURE

SGW819SDGCG01
SGW819SDGCW01

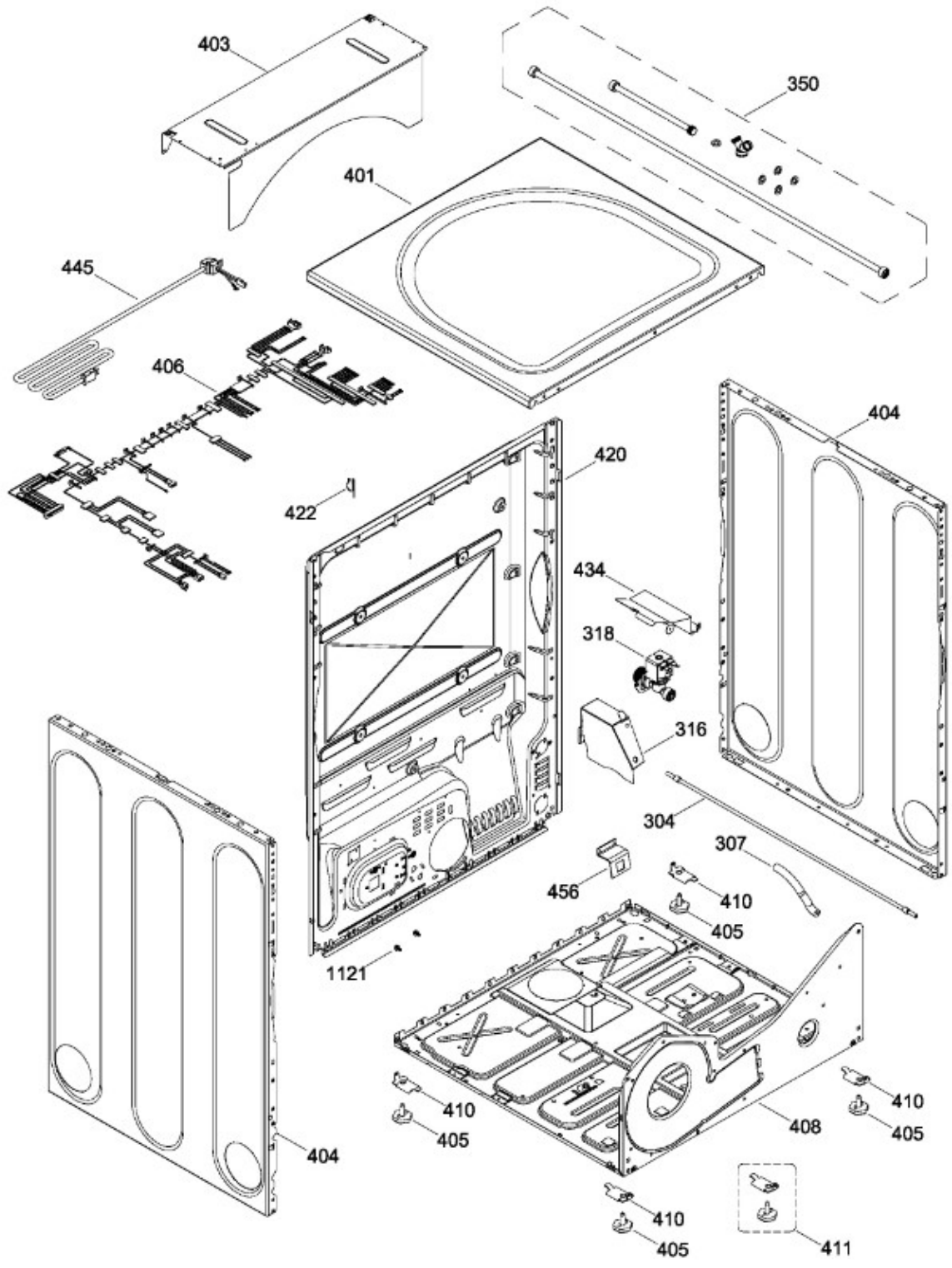

BENITO JUÁREZ #1500 GPE ZITON, CD. GUADALUPE NUEVO LEÓN TEL: 8183377999 Y 49
HORARIOS: LUNES A VIERNES 8:30 A 6:00 PM Y SÁBADOS DE 8:30 A 2:00 PM
WEB: www.denek.com



SECADORA SGW819SDGCW01

SISTEMA DE TRANSMISION (ENS) / BLOWER & DRIVE (ASM)

SGW819SDGCG01
SGW819SDGCW01

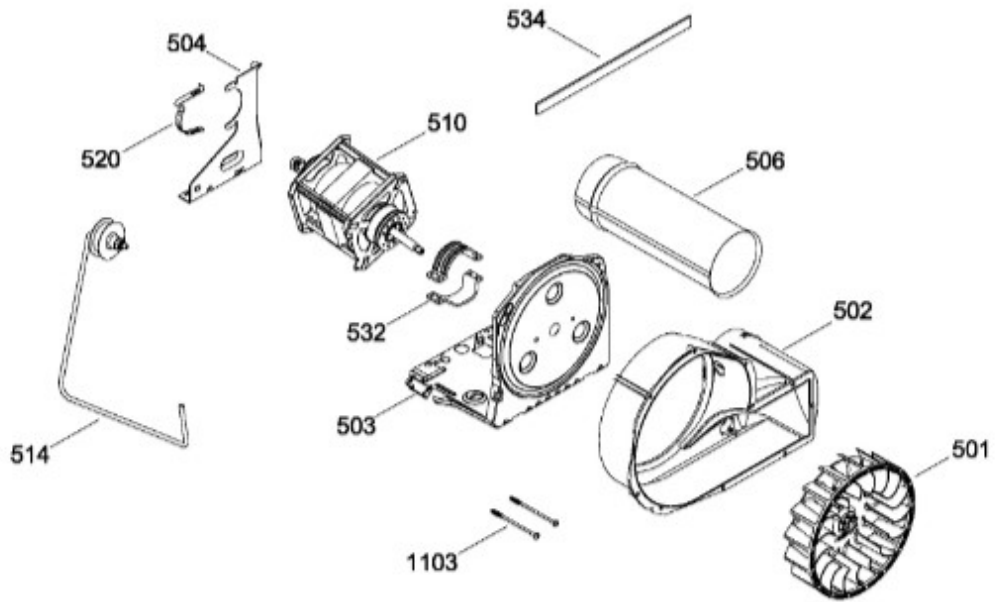

QUEMADOR / BURNER

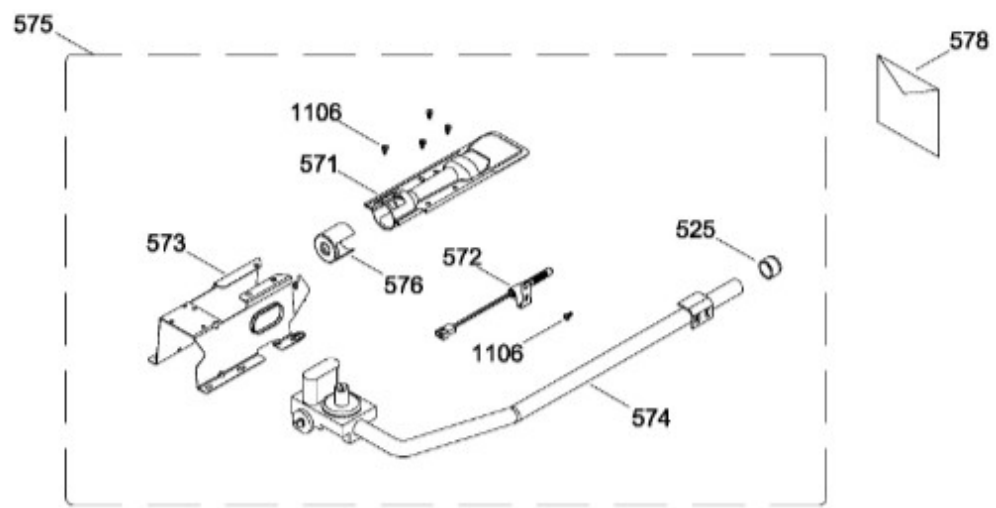



SECADORA SGW819SDGCW01

TAMBOR (ENS) / DRUM (ASM)

SGW819SDGCG01
SGW819SDGCW01

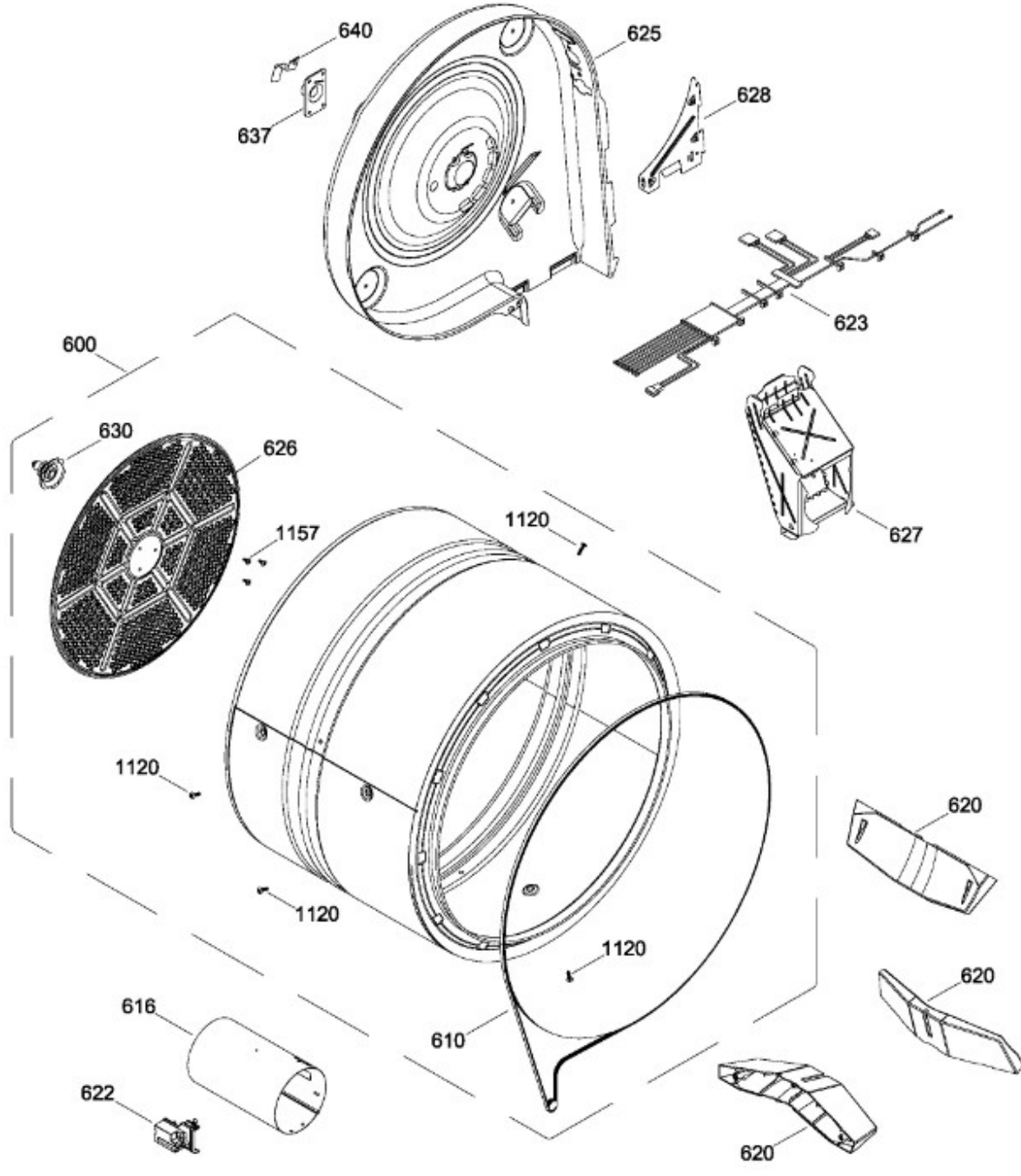

BENITO JUÁREZ #1500 GPE ZITON, CD. GUADALUPE NUEVO LEÓN TEL: 8183377999 Y 49
HORARIOS: LUNES A VIERNES 8:30 A 6:00 PM Y SÁBADOS DE 8:30 A 2:00 PM
WEB: www.denek.com

| Guía | Refacción | Descripción |
|------|------------|----------------------------|
| 1 | WW03F00434 | ENSAMBLE PANEL DE CONTROL |
| 2 | WW02A00180 | MANUAL DE USO Y CUIDADOS |
| 2 | WW02A00180 | MANUAL DE USO Y CUIDADOS |
| 7 | WW03L00343 | PERILLA |
| 14 | WW03F00492 | BARRERA TERMICA |
| 31 | WW03L00316 | ENSAMBLE CHASIS Y TARJETA |
| 31 | WW02F00787 | ENSAMBLE CHASIS Y TARJETA |
| 31 | WW02F00810 | CHASIS Y TARJETA ENSAMBLE |
| 32 | WW02L00411 | PROTECTOR FRONTAL |
| 33 | WW03F00489 | ENS BOTON EDRY/VOL/LOCK |
| 35 | WW03F00488 | ENS BOTON TEMP/LEVEL |
| 37 | WW03F00490 | ENS BOTON ADD TIME |
| 43 | WW03A00213 | GUIA DE LUZ SUPERIOR |
| 45 | WW03F00491 | ENS PANTALLA Y BOTONES |
| 100 | WW03L00371 | PANEL FRONTAL |
| 101 | WW03L00186 | MARCO Y FILTRO ENS |
| 101 | WW02F00614 | MARCO Y FILTRO ENS |
| 102 | WW02L00025 | INTERRUPTOR PUERTA |
| 103 | WW03L00187 | SELLO FILTRO |
| 108 | WW02L00172 | DOOR SWITCH COVER |
| 110 | WW02L00413 | COJINETE SUPERIOR ENSAMBLE |
| 110 | WW02L00520 | COJINETE SUPERIOR ENSAMBLE |
| 113 | WW01L01329 | FELPA COLECTOR DE AIRE |
| 113 | WW02F00783 | FELPA COLECTOR DE AIRE |
| 115 | WW03A00015 | COJINETE DESLIZABLE |
| 116 | WW03A00016 | COJINETE DESLIZABLE |
| 116 | WW02A00250 | COJINETE DESLIZABLE |
| 119 | WW02F00131 | FIELTRO |
| 119 | WW02F00784 | FIELTRO |
| 123 | WW02A00056 | STRIKE PLATE |
| 124 | WW02A00057 | STRIKE PLATE |
| 125 | WW02F00088 | SENSOR ROD |
| 127 | WW02A00067 | LAMP |
| 127 | WW03F00458 | LAMP |
| 127 | WW03F00458 | LAMPARA |

| Guía | Refacción | Descripción |
|------|------------|---------------------------|
| 128 | WW03A00117 | SELLO |
| 129 | WW03F00469 | HARNAIS DE FIL |
| 135 | WW03F00307 | SEGURO |
| 136 | WW03L00221 | TAPON CIEGO(GRIS) |
| 137 | WW02F00372 | DUCTO TRAMPA ENSAMBLE |
| 137 | WW02F00603 | DUCTO TRAMPA ENSAMBLE |
| 138 | WW02A00092 | BOQUILLA |
| 139 | WW02F00121 | CODO |
| 141 | WW01F01458 | CONECTOR DE SERVICIO |
| 142 | WW02A00093 | NUT-STRIP DOOR GUIDE |
| 144 | WW02L00167 | DOOR GUIDE |
| 146 | WW02F00135 | HARNESS SENSORS |
| 152 | WW03L00190 | SELLO DUCTO TRAMPA |
| 152 | WW03F00354 | SELLO DUCTO TRAMPA |
| 202 | WW03L00375 | PUERTA SUBENSAMBLE |
| 202 | NLA | PUERTA SUBENSAMBLE |
| 205 | WW03L00320 | VENTANA EXTERIOR PUERTA |
| 205 | WW02L00570 | VENTANA EXTERIOR PUERTA |
| 206 | WW02L00338 | MASCARA PUERTA |
| 207 | WW03F00432 | ANILLO PUERTA EXTERIOR |
| 209 | WW02L00168 | DOOR INNER WINDOW |
| 213 | WW02L00037 | LATCH ASM. |
| 214 | WW03L00319 | JALADERA |
| 216 | WW02L00414 | SELLO PUERTA |
| 220 | WW03L00374 | BISAGRA ENSAMBLE |
| 236 | WW02A00065 | BOTON BELLEZA |
| 238 | WW02A00082 | BEAUTY BOTTON |
| 240 | WW02L00372 | COVER HINGE |
| 304 | WW03F00317 | TUBO |
| 305 | WW03F00132 | TUBO FRONTAL |
| 307 | WW03F00133 | AISLANTE |
| 316 | WW03L00202 | PROTECTOR VALVULA DE AGUA |
| 318 | WW02F00182 | VALVULA DE AGUA |
| 350 | WW02A00088 | KIT MANGUERAS EXTERNAS |
| 401 | WW03L00229 | CUBIERTA SUPERIOR(BCO) |

| Guía | Refacción | Descripción |
|------|------------|-------------------------------|
| 403 | WW02L00197 | REAR PLATE |
| 403 | WW02F00720 | REAR PLATE |
| 404 | WW03L00205 | LATERAL(BCO) |
| 404 | WW03L00205 | LATERAL(BCO) |
| 404 | WW02L00644 | LATERAL(BCO) |
| 405 | WW02L00191 | PATTE DE NIVELLEMENT |
| 406 | WW03F00475 | ARNES GAS ENSAMBLE |
| 408 | WW03L00230 | BASE CHASIS |
| 409 | WW03A00160 | LOGO GE |
| 410 | WW02A00113 | SUPPORT (PATTE DE NIVELLEMENT |
| 411 | WW02F00139 | PATA NIVELADORA ENS |
| 420 | WW02L00196 | PANEL POSTERIOR |
| 422 | WW02F00022 | CORD SET RETAINER |
| 434 | WW03L00110 | CUBIERTA TERMOSTATO |
| 445 | WW02F00091 | CABLE TOMACORRIENTE |
| 456 | WW02A00037 | BRIDE |
| 501 | WW01F01162 | VENTILADOR REDONDO |
| 502 | WW03F00311 | CAJA VENTILADOR |
| 503 | WW01L01163 | BASE MOTOR |
| 503 | WW01L01163 | BASE MOTOR |
| 503 | WW01L01163 | BASE MOTOR |
| 503 | WW02L00642 | BASE MOTOR |
| 504 | WW02F00027 | SOPORTE MOTOR |
| 506 | WW02F00129 | DUCTO DE ESCAPE |
| 506 | WW02F00129 | DUCTO DE ESCAPE |
| 506 | WW02F00721 | EXHAUST DUCT |
| 510 | WW02F00015 | MOTOR POLEA ENS. |
| 510 | WW03A00209 | MOTOR POLEA ENS. |
| 514 | WW02A00008 | ENS. BRAZO AUXILIAR |
| 514 | WW03F00350 | ENS. BRAZO AUXILIAR |
| 520 | WW02F00031 | CLIP MOTOR |
| 525 | WW02A00003 | TAPA |
| 532 | WW02F00003 | CORREA MOTOR |
| 532 | WW02A00232 | CORREA MOTOR |
| 534 | WW02A00026 | EMPAQUE ESCAPE SOPLADOR |

| Guía | Refacción | Descripción |
|------|------------|-------------------------------|
| 534 | WW02F00785 | EMPAQUE ESCAPE SOPLADOR |
| 571 | WW02A00020 | QUEMADORES |
| 572 | WW02F00002 | ALLUME-GAZ |
| 572 | WW02F00740 | ALLUME-GAZ |
| 573 | WW03A00125 | SOPORTE VALVULA DE GAS |
| 574 | WW02A00155 | ENS VALVULA Y TUBERIA GAS NAT |
| 575 | WW03F00493 | ENSAMBLE VALVULA Y QUEMADOR |
| 576 | WW02L00140 | AIRADOR |
| 578 | WW01F01529 | VALVULA Y TUBO PARA GAS LP |
| 600 | WW03F00320 | TAMBOR ENSAMBLE |
| 610 | WW02F00028 | BANDA SECADORA |
| 610 | WW02F00854 | BANDA SECADORA |
| 616 | WW03F00296 | CAMARA DE COMBUSTION |
| 616 | WW03F00296 | CAMARA DE COMBUSTION |
| 616 | WW02F00722 | TUBO DE COMBUSTION |
| 620 | WW03L00372 | ALETA |
| 622 | WW02F00001 | DETECTOR TERMOSTATO |
| 623 | WW03F00478 | ARNES GAS |
| 625 | WW03F00095 | DIFUSOR DE GAS |
| 626 | WW02F00221 | DIFUSOR |
| 626 | WW02F00827 | DIFUSOR |
| 627 | WW02F00127 | DUCTO TRANSICION |
| 627 | WW02F00127 | DUCTO TRANSICION |
| 627 | WW03F00539 | DUCTO TRANSICION |
| 628 | WW03F00097 | PLACA DIFUSOR |
| 630 | WW02A00019 | SOPORTEYFLECHAENSAMBLE |
| 637 | WW02A00005 | RETENEDOR RODAMIENTO |
| 640 | WW01A00443 | GROUND STRAP ASSEMBLY |
| 640 | WW02F00833 | GROUND STRAP ASSEMBLY |
| 700 | WW02A00102 | SCREW CHASSIS TO FRONT HSG. |
| 704 | WW02A00099 | SCREW # 10 |
| 708 | WW02A00098 | SCREW |
| 708 | WW01A00539 | SCREW |
| 711 | WW02A00101 | TORNILLO |
| 723 | WW03A00145 | TORNILLO HI/LO 8-18 |

| Guía | Refacción | Descripción |
|------|------------|--------------------------|
| 728 | WW02A00114 | TUERCAS |
| 729 | WW03A00146 | ARANDELAS |
| 731 | WW02A00120 | CALZA |
| 732 | WW03A00092 | TORNILLO 6-16 B B1Q1 3/4 |
| 734 | WW03A00156 | TORNILLO 8-18 AB PNQ2 |
| 1103 | WW02A00032 | TORNILLO |
| 1106 | WW02A00027 | SCREW |
| 1115 | WW01A00450 | TORNILLO 8-18 AB 1/2 |
| 1120 | WW02A00031 | TORNILLO |
| 1121 | WW01A00001 | TORNILLO |
| 1157 | WW01A00456 | TORNILLO #10 |