



EXPLOSIONADO DE PARTES

— LAVADORA UNA TINA —

MODELO | SLP1953EG

LAVADORA SLP1953EG

Marca	Supermatic
Capacidad	20 Kgs.
Color	Gris
Tina / Faldon	

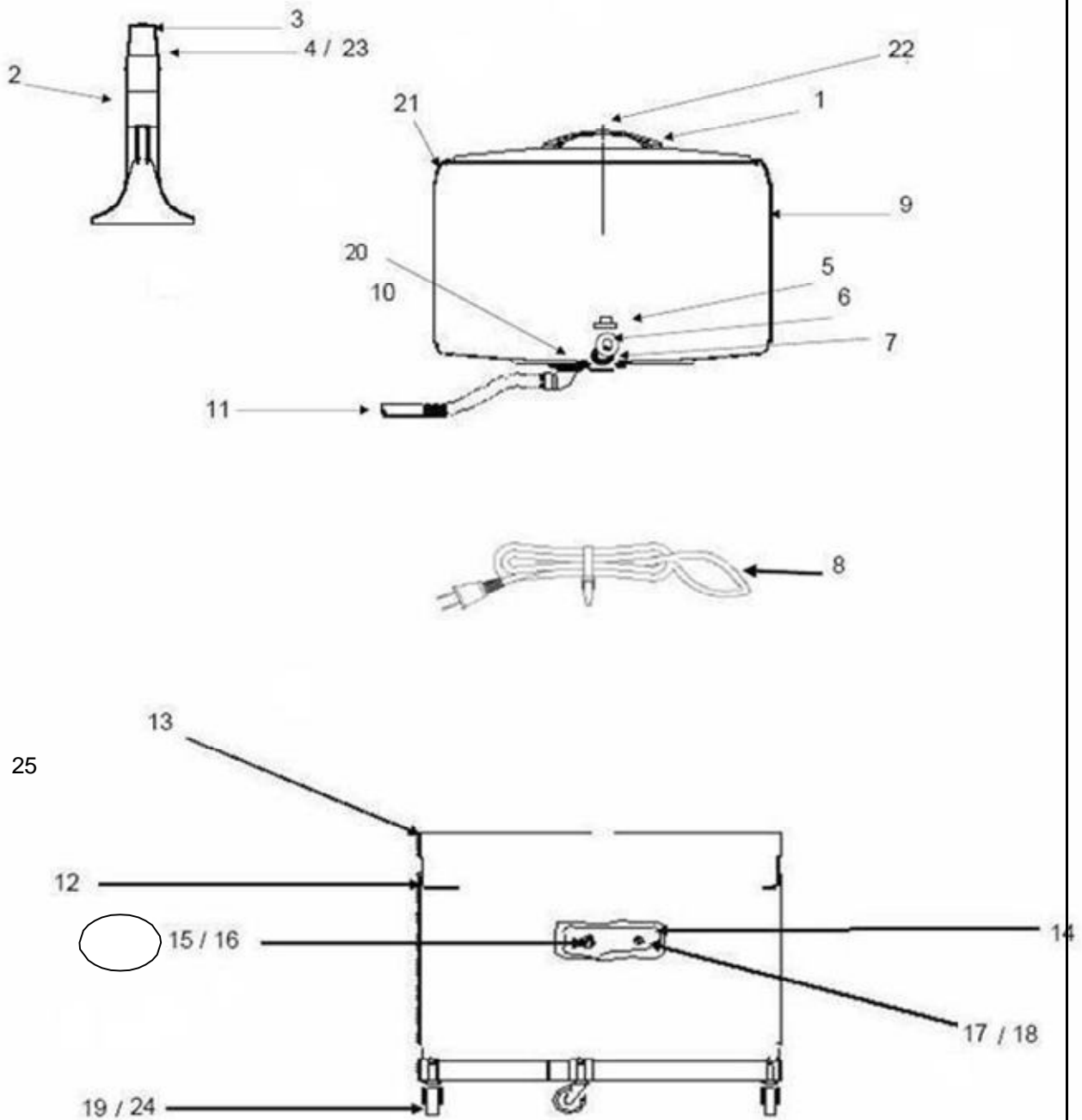



LAVADORA SLP1953EG

Marca		Supermatic	
Capacidad		20 Kgs.	
Color		Gris	
Tina / Faldon			
R e f	Descripción	C a n t	Numero de Parte
1	CONJUNTO TAPA TINA	1	-
2	CONJUNTO CUERPO AGITADOR	1	8567936
3	TAPON AGITADOR	1	8567975
4	TORNILLO AGITADOR	1	W10307187
5	TUERCA POSTE	1	92311108
6	ARANDELA PLANA(7/16)	1	8057844
7	ARANDELA PLANA HULE 17/8	1	VS611
8	CABLE TOMACORRIENTE	1	W11112407
9	CONJUNTO TINAS	1	W10155137
10	CASQUILLO MANGUERA	1	8568190
11	CONJUNTO MANG.DE DESAGUE	1	W10337008
12	HOLDER SUJETADOR CONJ MANG.	*	8568190
13	CONJUNTO FALDON	1	W10871789
14	SELLO FALDON TINA	1	W11339520
15	PANEL DE CONTROL	1	W10871791
16	TORNILLO 6-20 X 5/16 PN CR/TIMER	*	8317813
17	PERILLA TIMER 15 MIN	1	W11416045
18	SWITCH SELECTOR	1	3954129
19	PERILLA SWITCH	1	W11416046
20	CONJUNTO CASQUILLO RODAJA 2"	1	8567759
21	PROTECTOR TINA	1	8567931
22	EMPAQUE TAPA VOLCAN	1	8567942
23	JALADERA TAPA VOLCAN	1	8567856
24	TACO BASE MACHO	1	8317473
25	C-RING FOR CASTER/VOLCAN	1	8567729
26	TIMER CTRL	1	W10572886

LAVADORA SLP1953EG

Marca	Supermatic
Capacidad	20 Kgs.
Color	Gris

Sistema Interno

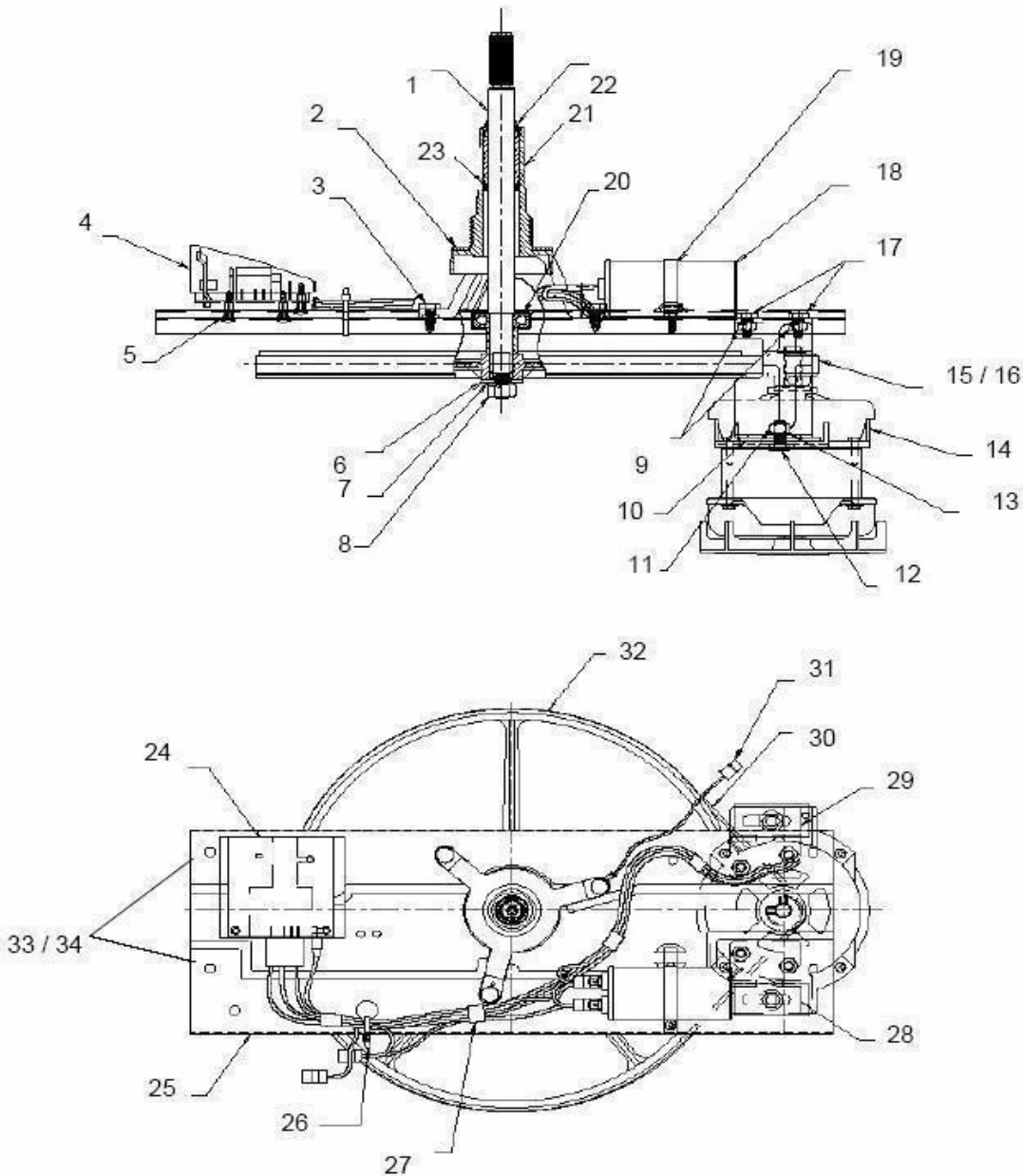

NOTA: Este es un dibujo generico y puede no reflejar la forma exacta de la pieza que usted posea fisicamente, pero el número de parte que aparece en el listado pertenece a la pieza correcta para el modelo en consulta.



LAVADORA SLP1953EG

Marca		Supermatic	
Capacidad		20 Kgs.	
Color		Gris	
Sistema Interno			
R e f	Descripción	C a n t	Numero de Parte
1	ENSAMBLE FLECHA AGITADOR	1	W10884824
2	ARANDELA PLANA HULE 17/8	1	VS611
3	PIJA21 H 1/4 14X 3/4	1	8317812
4	TARJETA DE CONTROL	1	W10572886
5	SUPPORT FOR BOARD	1	-
6	ARANDELA PLANA 7/16	1	8057844
7	ARANDELA DE PRESION (7/16)	1	8057819
8	TUERCA HEX FLECHA AGIT.	1	8057808
9	TUERCA 31 H 1/4 20	1	8057808
10	ESPACIADOR SOPORTE MOTOR	1	8057828
11	TUERCA 31 H 5/16 18	1	90984
12	TOR HEXAGONAL 5/16-18X3	1	8057843
13	ARANDELA PLANA 7/16	1	8057844
14	MOTOR HAIER	1	W10731739
15	POLEA MOTOR MAQ.	1	-
16	OPRESOR ALLEN 1/4-20X5/16	1	50007303
17	TORNILLO11 H 1/4 20X5	1	8546894
18	CAPACITOR M 50UF	1	W11218432
19	ABRAZADERA P/CAPACITOR	1	W10727085
20	BALERO RADIAL	1	W10712405
21	ENSAMBLE POSTE AGITADOR	1	W10307187
22	RETEN SUPERIOR	1	WP91939
23	RETEN INFERIOR 3/16X1"	1	WP356427
24	PROTECTOR TARJETA DE CONTROL	1	*****
25	BASE TRANSMISION	1	8057747
26	CINTILLA P/ARNES	1	3429563
27	ARNES 1 VELOCIDAD	1	W10755149
28	SOPORTE MOTOR IZQUIERDO	1	8057749
29	SOPORTE MOTOR DERECHO	1	8057750
30	BANDA MULTY-V	1	W11130864
31	WIRE GROUND	1	*****
32	POLEA AGITADOR	1	W10898060
33	PIJA21 H 1/4 14X 1/2	1	8317812
34	ARANDELA 45 H 1/4"	1	8057819