

PUERTA (ENS) / DOOR (ASM)

SMA14103EGG0

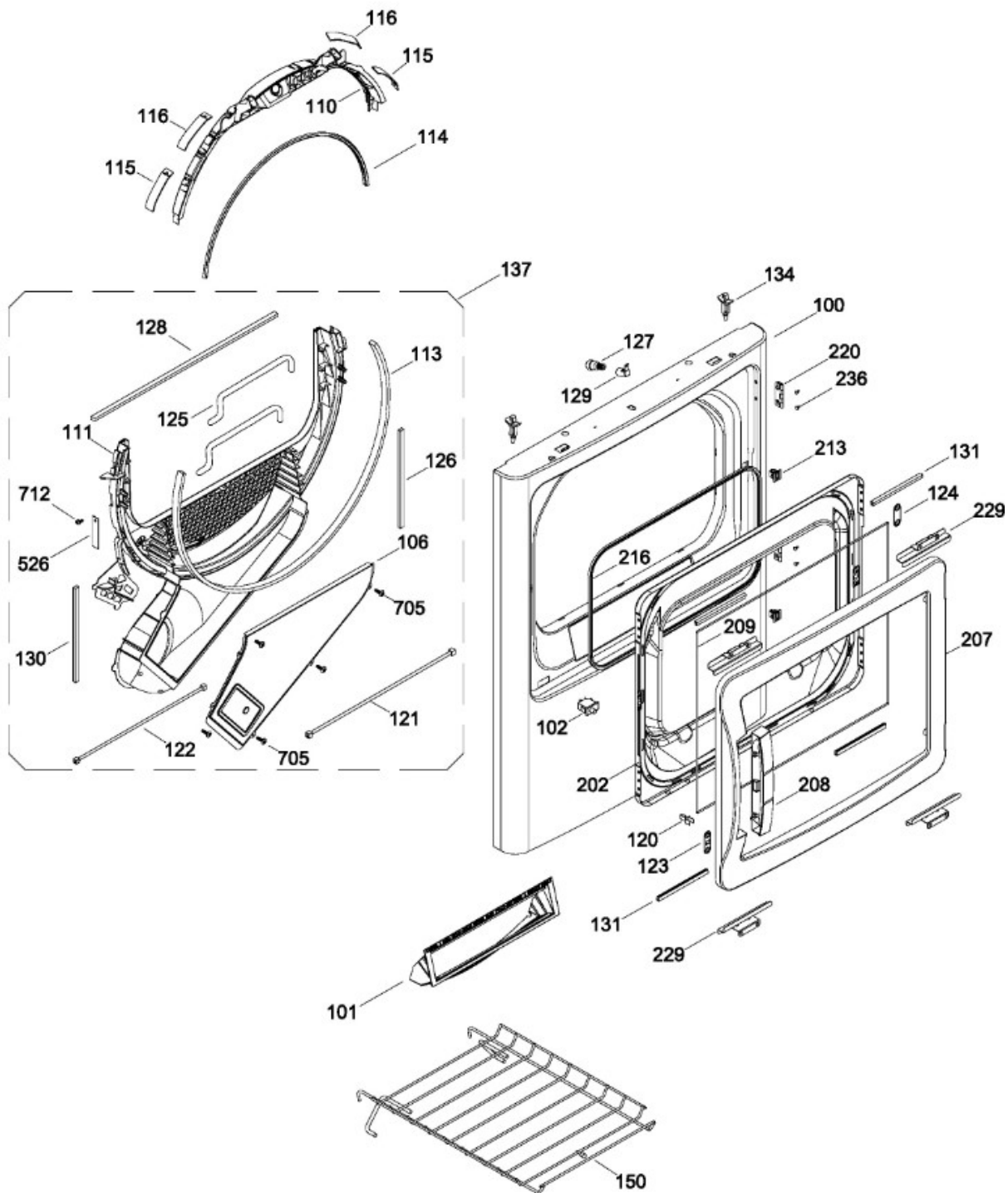

GABINETE / STRUCTURE

SMA14103EGG0

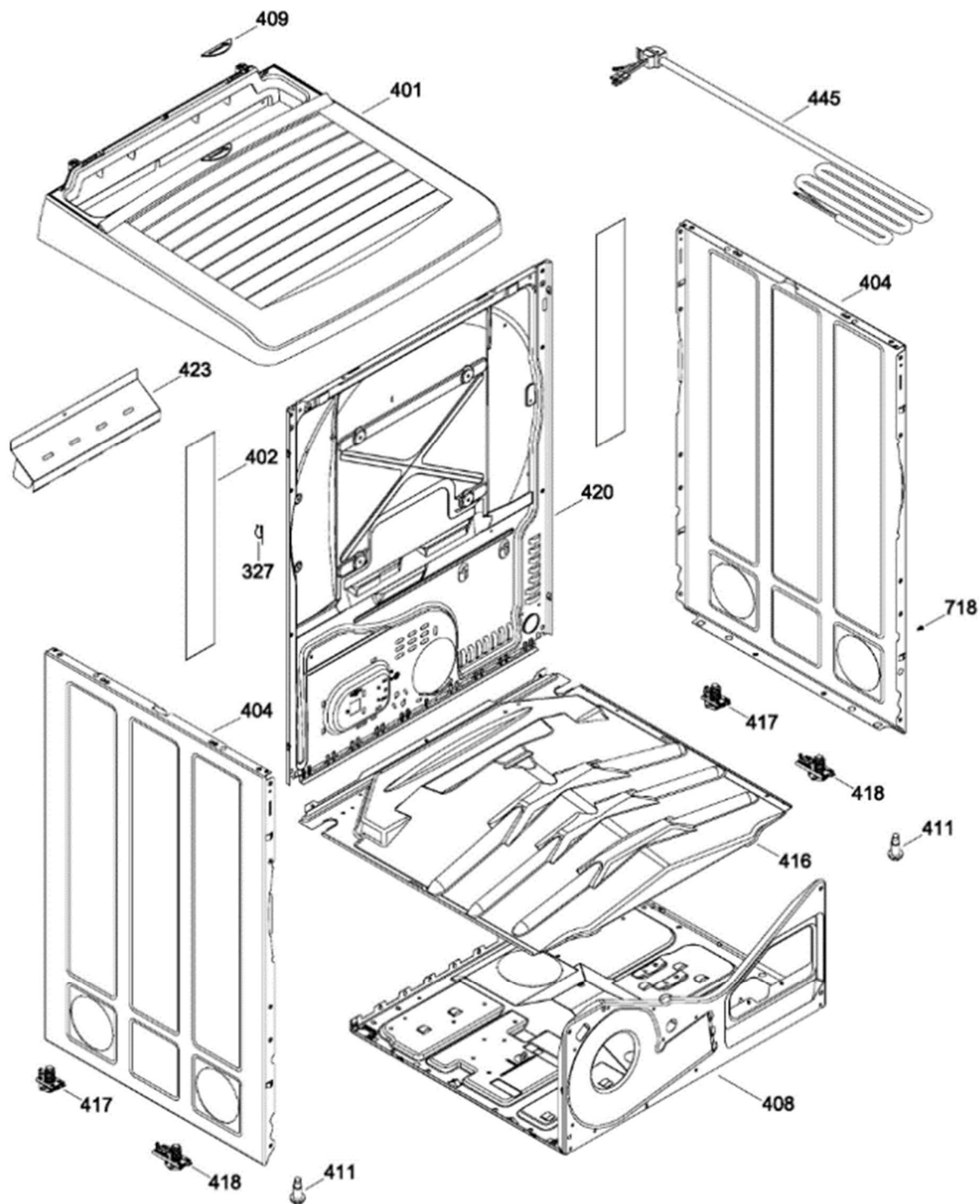

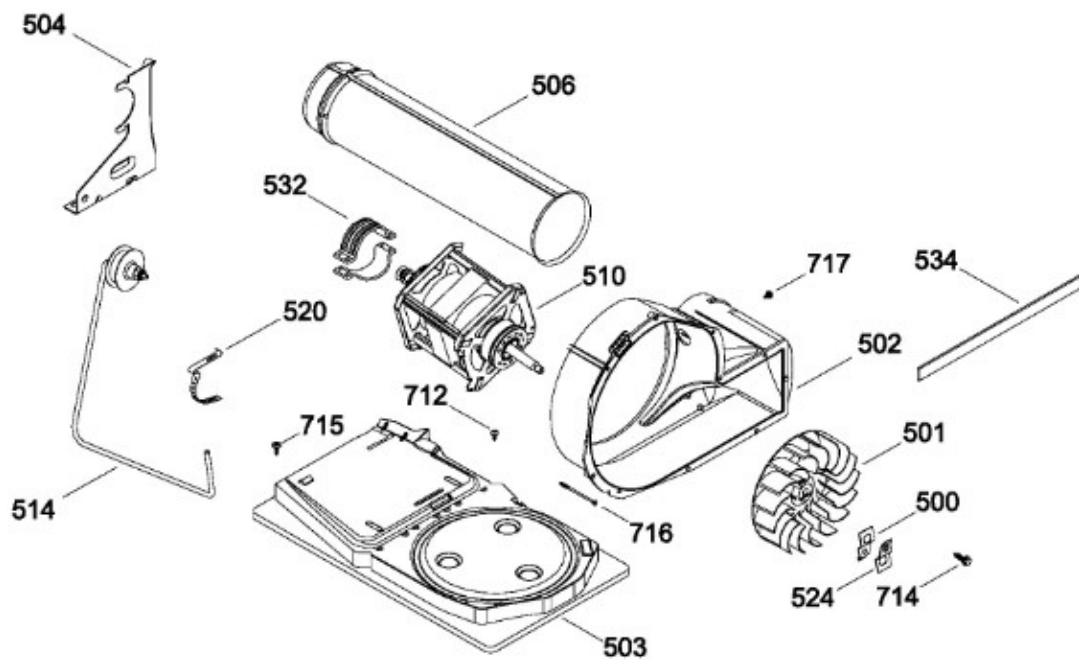

TAMBOR (ENS) / DRUM (ASM)

SMA14103EGG0

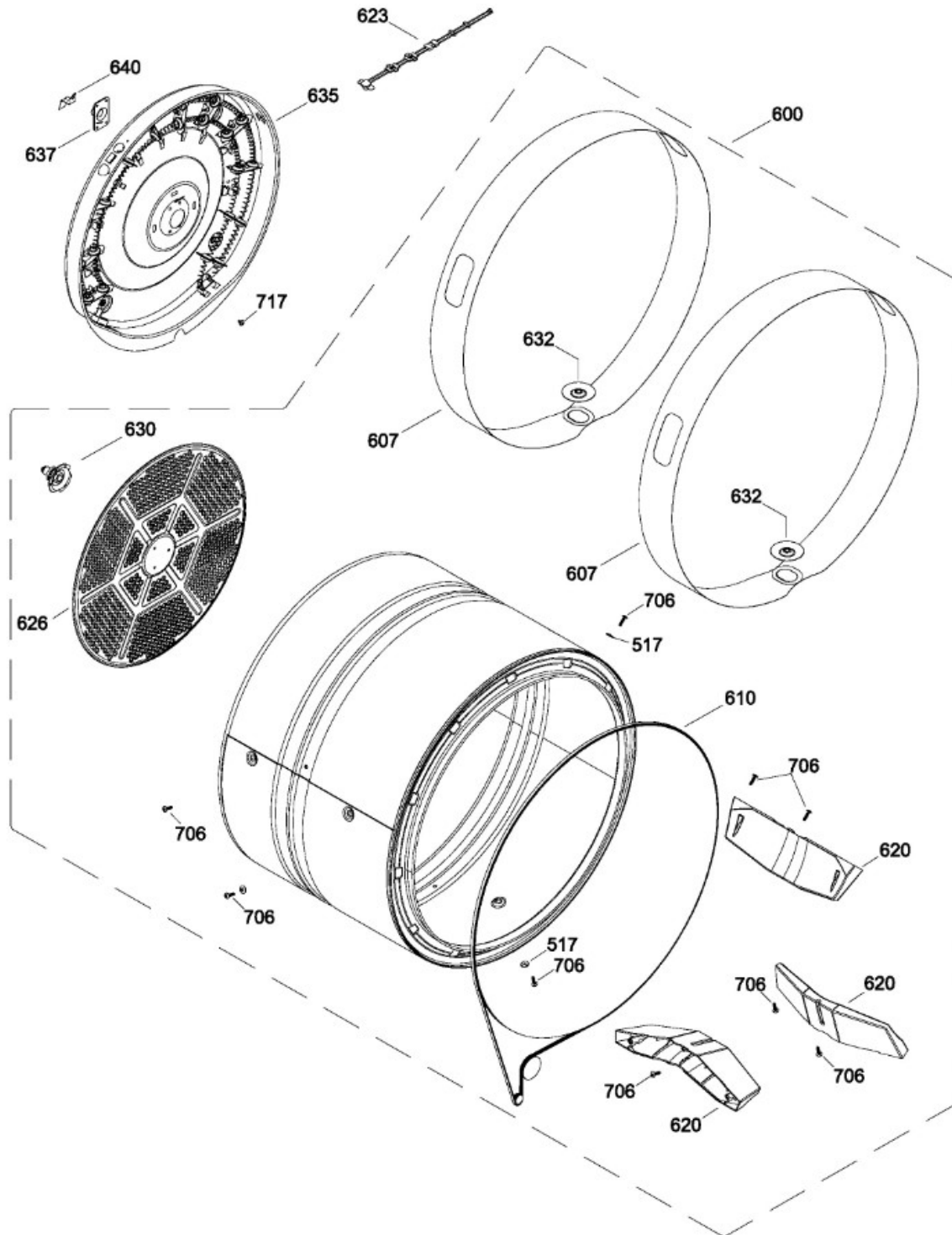

Guía	Refacción	Descripción
1	WW02L00060	COPETE
3	WW02F00038	OVERLAY
7	WW02L00124	ENS. PERILLA CONTROL
8	WW02L00122	ENS. PERILLA ROTATORIA
10	WW02F00067	RELOJ
10	WW02F00286	RELOJ
15	WW02F00040	ENS. ARNES
16	WW02L00083	INTERRUPTOR DE INICIO
18	WW02L00086	INTERRUPTOR ROTATORIO
27	WW02F00054	ARNES PANEL CONTROL
28	WW02A00046	CIRCUITO IMPRESO
36	WW02F00092	TARJETA PC
100	WW03L00098	PANEL FRONTAL PUERTA(GRAFITO)
100	WW03L00098	PANEL FRONTAL PUERTA(GRAFITO)
101	WW02L00080	ENS. FILTRO MALLA
101	WW02F00616	ENS. FILTRO MALLA
102	WW02L00025	INTERRUPTOR PUERTA
106	WW02L00061	CUBIERTA DUCTO
110	WW02F00010	COJINETE SUP.
110	WW01L01430	COJINETE SUP.
111	WW02F00178	TRAMPA CONDUCTO
111	WW02L00103	TRAMPA CONDUCTO
111	WW02F00600	DUCTO
113	WW02L00139	FIELTRO
113	WW02L00138	FIELTRO
114	WW02L00145	SELLO PUERTA
115	WW02A00033	BEARING_SLIDE
116	WW02L00038	BEARING_SLIDE
120	WW02A00004	STRIKE
121	WW02A00051	ARNES
122	WW02A00052	ARNES
123	WW02A00056	STRIKE PLATE
124	WW02A00057	STRIKE PLATE
125	WW02F00088	SENSOR ROD
126	WW02L00039	SELLO
126	WW03F00354	SELLO
127	WW02A00067	LAMP
127	WW03F00458	LAMP

Guía	Refacción	Descripción
127	WW03F00458	LAMPARA
128	WW02L00041	SELLO
129	WW02L00104	ENS. CLAVIJA
129	WW01F01584	ENS. CLAVIJA
130	WW02L00042	SELLO
131	WW02L00102	RETAINER GASKET
134	WW02A00035	SOPORTE BLOQUEO
137	WW02F00128	DUCTO TRAMPA ENS CON SENSORES
137	WW02F00599	DUCTO TRAMPA ENS CON SENSORES
150	WW02L00088	SHOE RACK
150	WW02L00190	SHOE RACK
202	WW02L00054	INNER DOOR
202	WW02L00054	INNER DOOR
202	WW02L00054	PUERTA INTERIOR
207	WW02F00033	ANILLO EXT.
207	WW01L01492	ANILLO EXT.
208	WW02L00057	JALADERA
208	WW01L01494	JALADERA
209	WW02L00058	PANEL VIDRIO
213	WW02L00037	LATCH ASM.
216	WW02L00062	SELLO VENTANA
220	WW02L00029	BISAGRA
220	WW02L00028	BISAGRA
229	WW02L00101	SOPORTE VIDRIO
229	WW02L00101	SOPORTE VIDRIO
229	WW02L00101	SOPORTE VIDRIO
236	WW02A00066	BOTON BELLEZA
327	WW02F00022	CORD SET RETAINER
401	WW02L00066	ENS. CUBIERTA SUP. PLASTICA
402	WW02L00147	DAMPENING PLATE
404	212D1615P005	PANEL LATERAL(GRAFITO)
408	WW02F00076	BASTIDOR BASE
409	WW01L00369	LOGO ID SYSTEM
411	WW02L00142	PATA ESTABILIZADORA ENS.
416	WW02A00045	DEFLECTOR
416	WW02A00045	DEFLECTOR
416	WW02A00045	DEFLECTOR DE CALOR
417	WW02A00059	ENS. SOPORTE POST.

Guía	Refacción	Descripción
418	WW02L00108	ENS. SOPORTE FRONT.
420	WW02L00146	PANEL POST.
423	WW02L00107	ESCUDO CALOR POST.
445	WW02F00016	CORDON TOMACORRIENTE
500	WW02A00040	ABRAZADERA VENTILADOR
501	WW02A00073	VENTILADOR REDONDO
502	WW02A00012	CARCAZA ASPAS
502	WW02L00013	CARCAZA ASPAS
502	WW02L00433	CAJA DEL VENTILADOR
503	WW02F00098	PLATO MOTOR
504	WW02F00027	SOPORTE MOTOR
506	572D559P006	CONDUCTO DE ESCAPE
510	WW02F00083	MOTOR POLEA VENTILADOR
510	WW01F00630	MOTOR POLEA VENTILADOR
510	WW03A00209	MOTOR POLEA VENTILADOR
514	WW02A00008	ENS. BRAZO AUXILIAR
514	WW03F00350	ENS. BRAZO AUXILIAR
517	WW02A00002	ARANDELA
520	WW02F00031	CLIP MOTOR
524	WW02A00041	ABRAZADERA VENTILADOR
526	WW02L00033	ESPACIADOR ESPUMADO
532	WW02F00003	CORREA MOTOR
532	WW02A00232	CORREA MOTOR
534	WW02A00026	EMPAQUE ESCAPE SOPLADOR
534	WW02F00785	EMPAQUE ESCAPE SOPLADOR
600	WW02F00057	ENS. TAMBOR
607	WW02L00098	BANDA TAMBOR
610	WW02F00028	BANDA SECADORA
610	WW02F00854	BANDA SECADORA
620	WW02L00143	BAFFLE
623	WW02F00048	ARNES
626	WW02F00030	DIFUSOR
630	WW02A00019	SOPORTE Y FLECHA ENSAMBLE
632	WW02A00072	RONDANDA BANDA
635	WW02A00049	ENS. CALENTADOR
635	WW02A00049	ENS. CALENTADOR
637	WW02A00005	RETENEDOR RODAMIENTO
640	WW02F00026	GROUND STRAP ASM.



Guía	Refacción	Descripción
640	WW01A00443	GROUND STRAP ASM.
640	WW02F00833	GROUND STRAP ASSEMBLY
705	WW02A00028	TORNILLO
706	WW02A00031	TORNILLO
712	WW02A00029	TORNILLO
712	WW02A00211	TORNILLO
714	WW02A00071	TORNILLO
715	WW02A00070	TORNILLO
716	WW02A00032	TORNILLO
717	WW02A00030	TORNILLO
717	WW02A00211	TORNILLO
718	WW01A00001	TORNILLO