

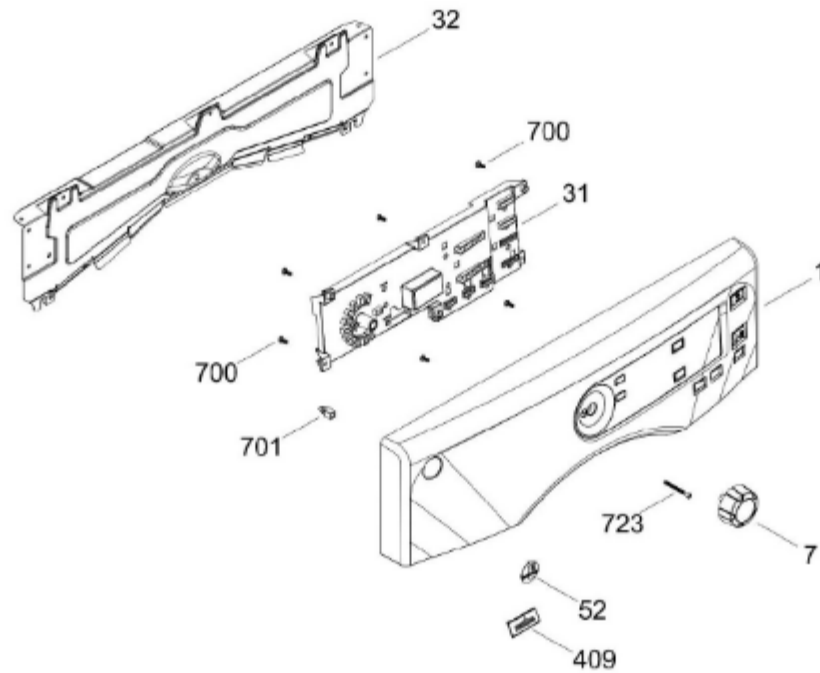

SECADORA SMW715NDGWW00

SISTEMA CONTROLES / CONTROL SYSTEM

SMW715NDGWW00



BENITO JUÁREZ #1500 GPE ZITON, CD. GUADALUPE NUEVO LEÓN TEL: 8183377999 Y 49
HORARIOS: LUNES A VIERNES 8:30 A 6:00 PM Y SÁBADOS DE 8:30 A 2:00 PM
WEB: www.denek.com



SECADORA SMW715NDGW00

PANEL FRONTAL (ENS) / FRONT PANEL (ASM)

SMW715NDGW00

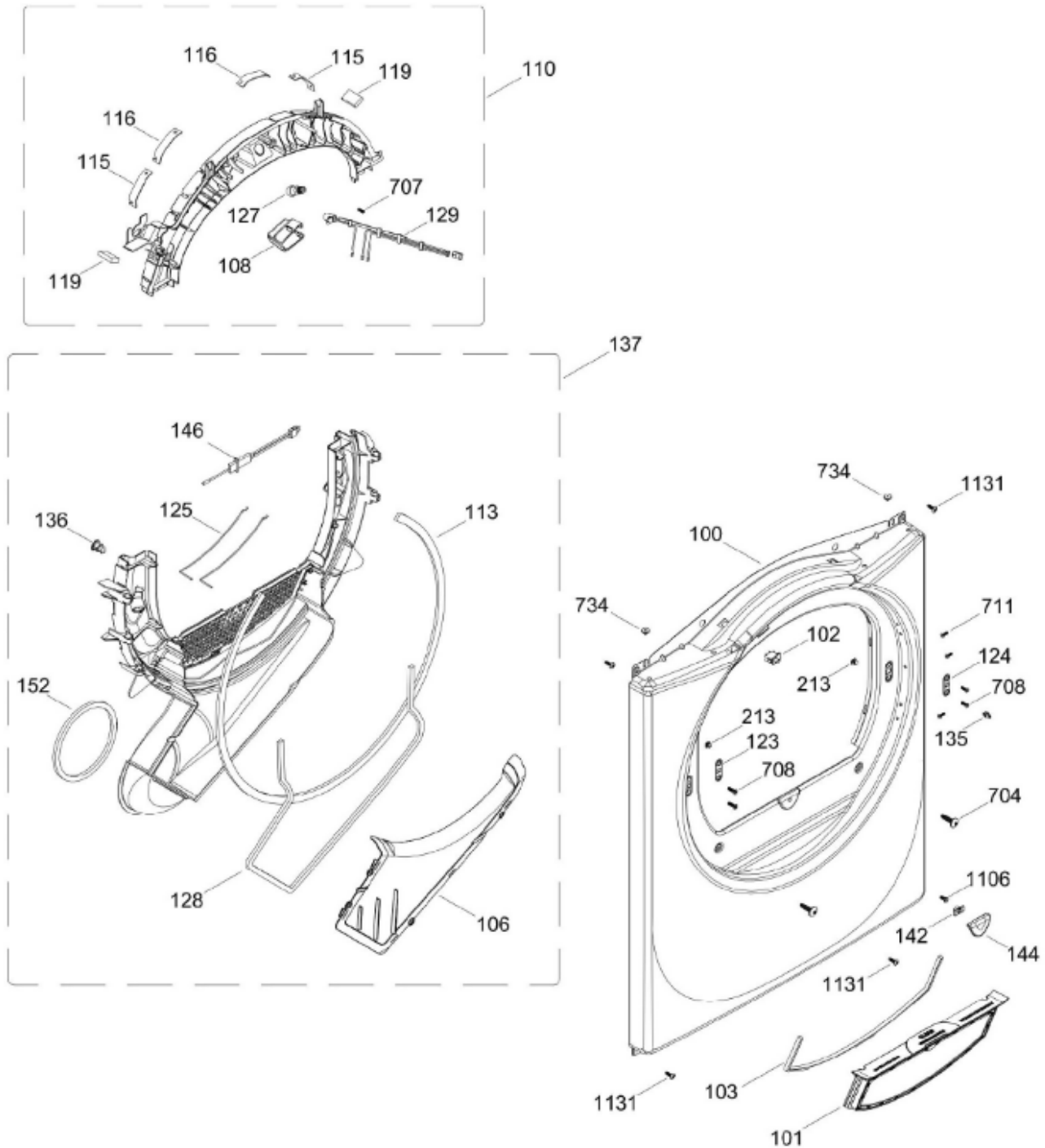

BENITO JUÁREZ #1500 GPE ZITON, CD. GUADALUPE NUEVO LEÓN TEL: 8183377999 Y 49
HORARIOS: LUNES A VIERNES 8:30 A 6:00 PM Y SÁBADOS DE 8:30 A 2:00 PM
WEB: www.denek.com



SECADORA SMW715NDGWW00

PUERTA (ENS) / DOOR (ASM)

SMW715NDGWW00

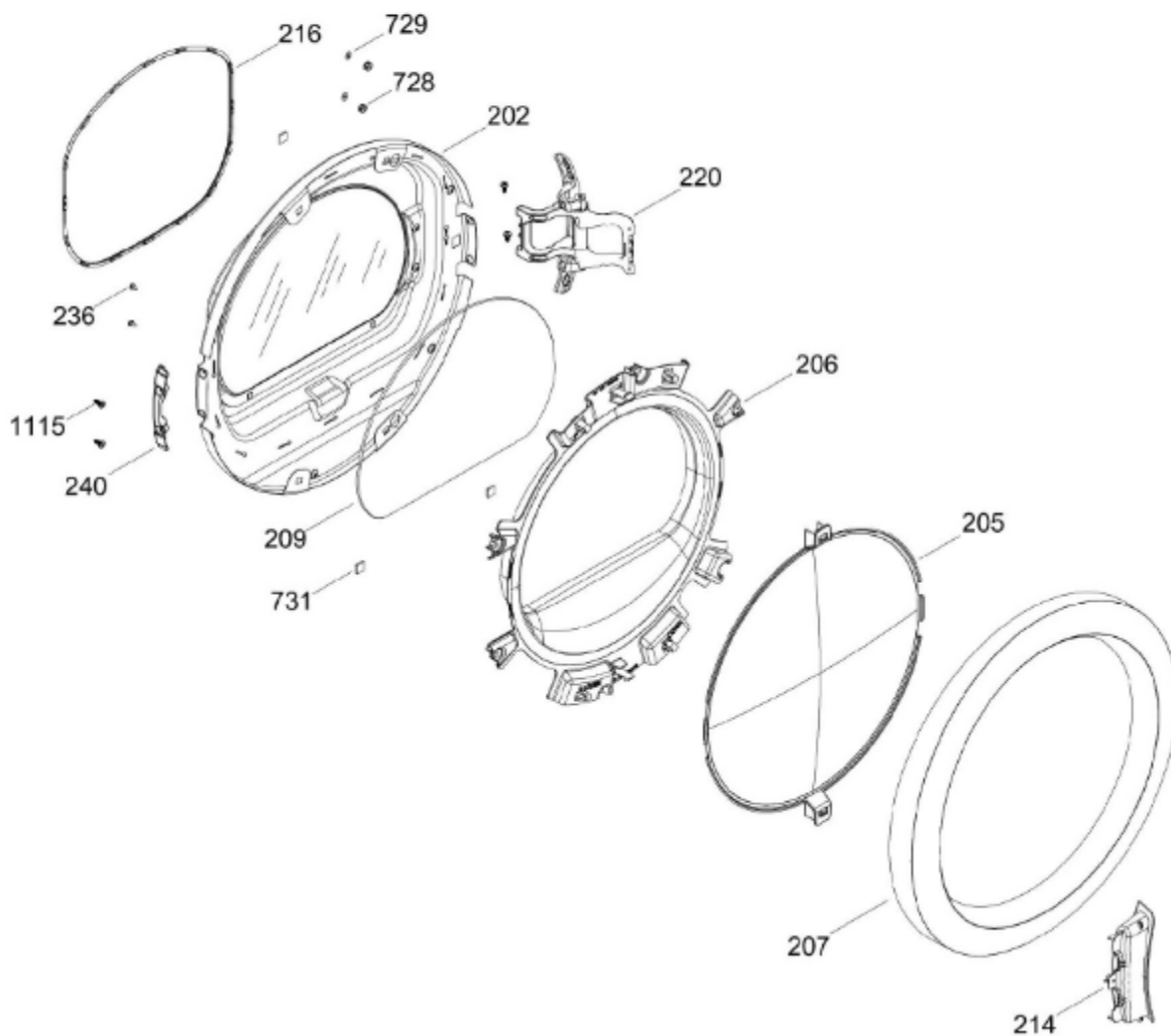

BENITO JUÁREZ #1500 GPE ZITON, CD. GUADALUPE NUEVO LEÓN TEL: 8183377999 Y 49
HORARIOS: LUNES A VIERNES 8:30 A 6:00 PM Y SÁBADOS DE 8:30 A 2:00 PM
WEB: www.denek.com



SECADORA SMW715NDGWW00

GABINETE / STRUCTURE

SMW715NDGWW00

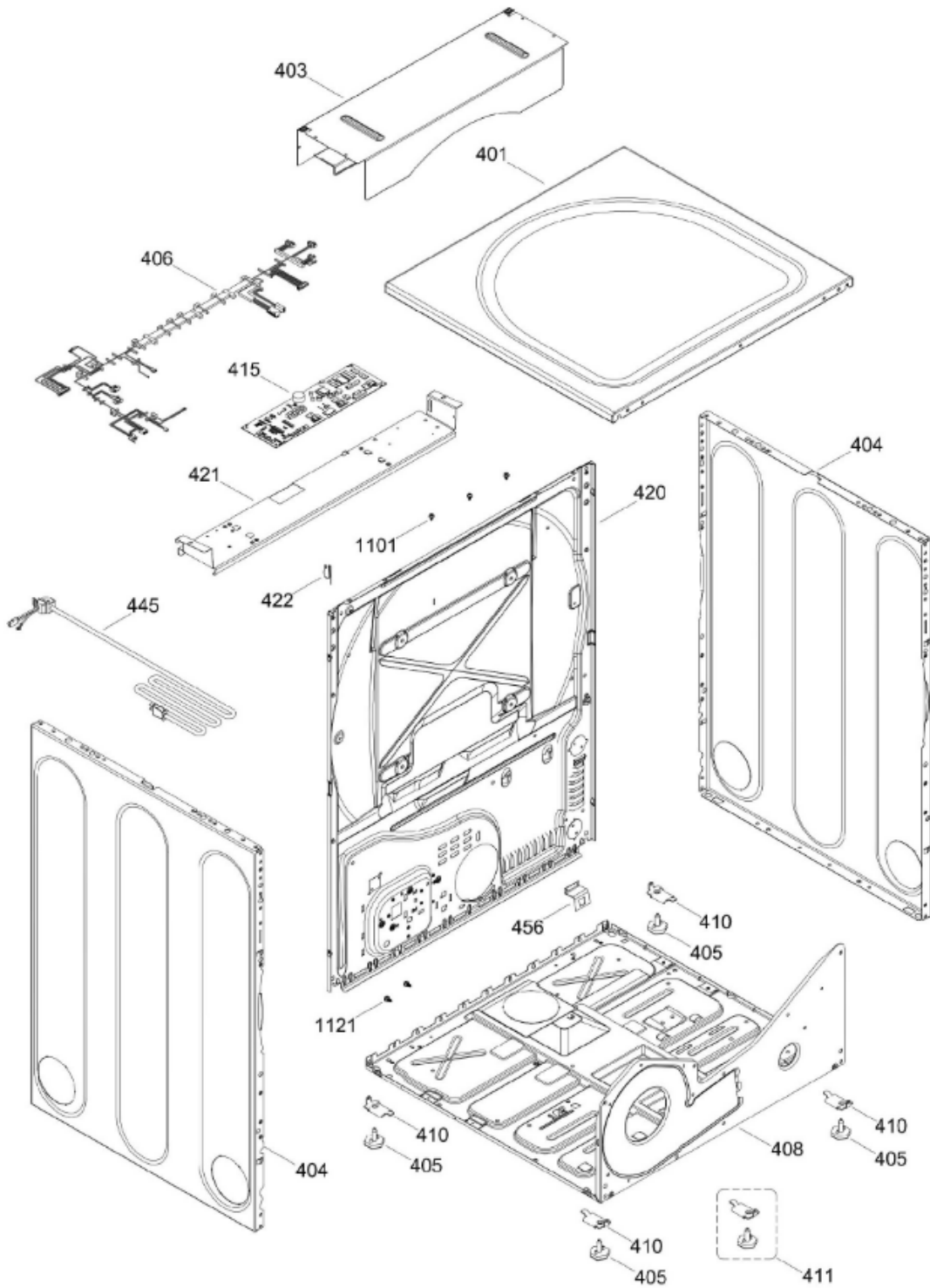

BENITO JUÁREZ #1500 GPE ZITON, CD. GUADALUPE NUEVO LEÓN TEL: 8183377999 Y 49
HORARIOS: LUNES A VIERNES 8:30 A 6:00 PM Y SÁBADOS DE 8:30 A 2:00 PM
WEB: www.denek.com



SECADORA SMW715NDGWW00

SISTEMA DE TRANSMISION (ENS) / BLOWER & DRIVE (ASM)

SMW715NDGWW00

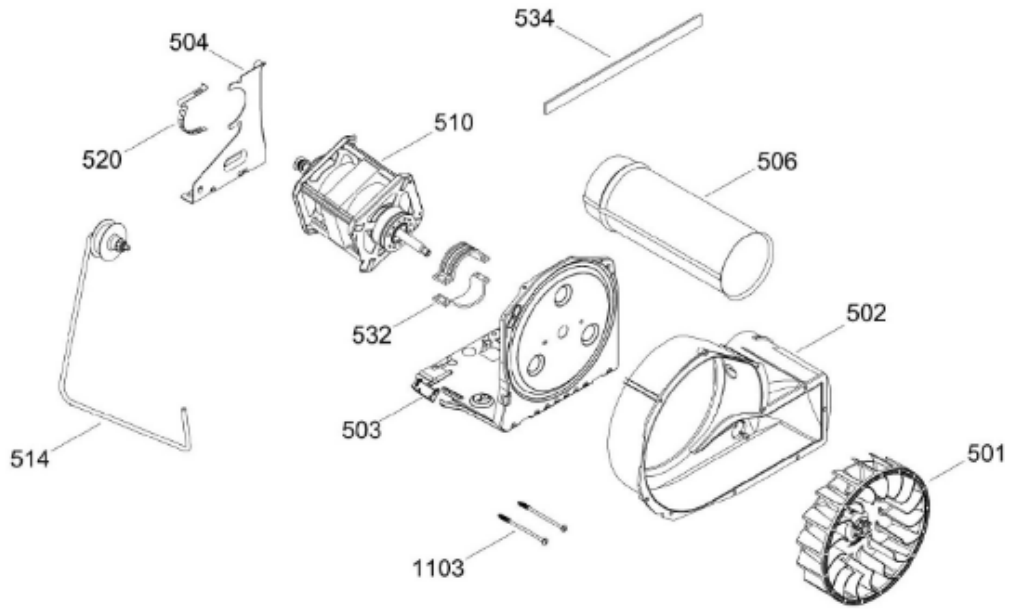

QUEMADOR / BURNER

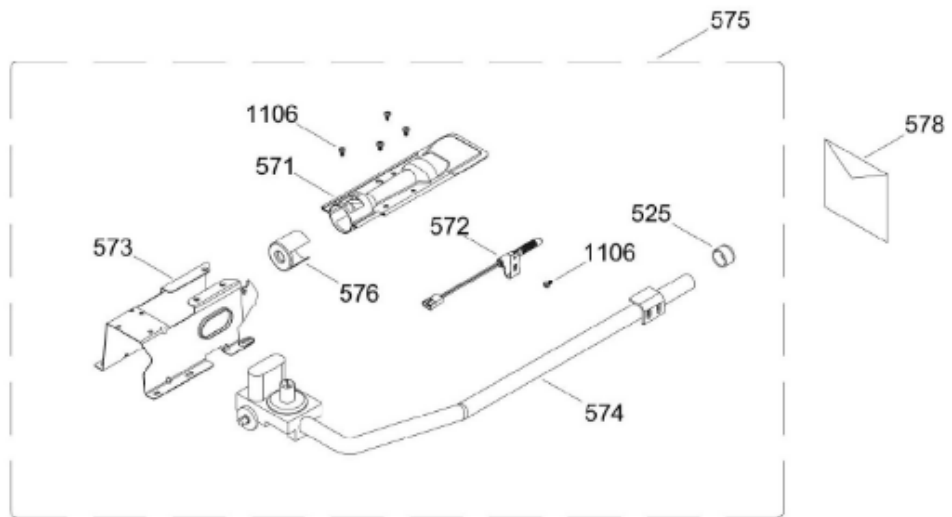

BENITO JUÁREZ #1500 GPE ZITON, CD. GUADALUPE NUEVO LEÓN TEL: 8183377999 Y 49
HORARIOS: LUNES A VIERNES 8:30 A 6:00 PM Y SÁBADOS DE 8:30 A 2:00 PM
WEB: www.denek.com



SECADORA SMW715NDGWW00

TAMBOR (ENS) / DRUM (ASM)

SMW715NDGWW00

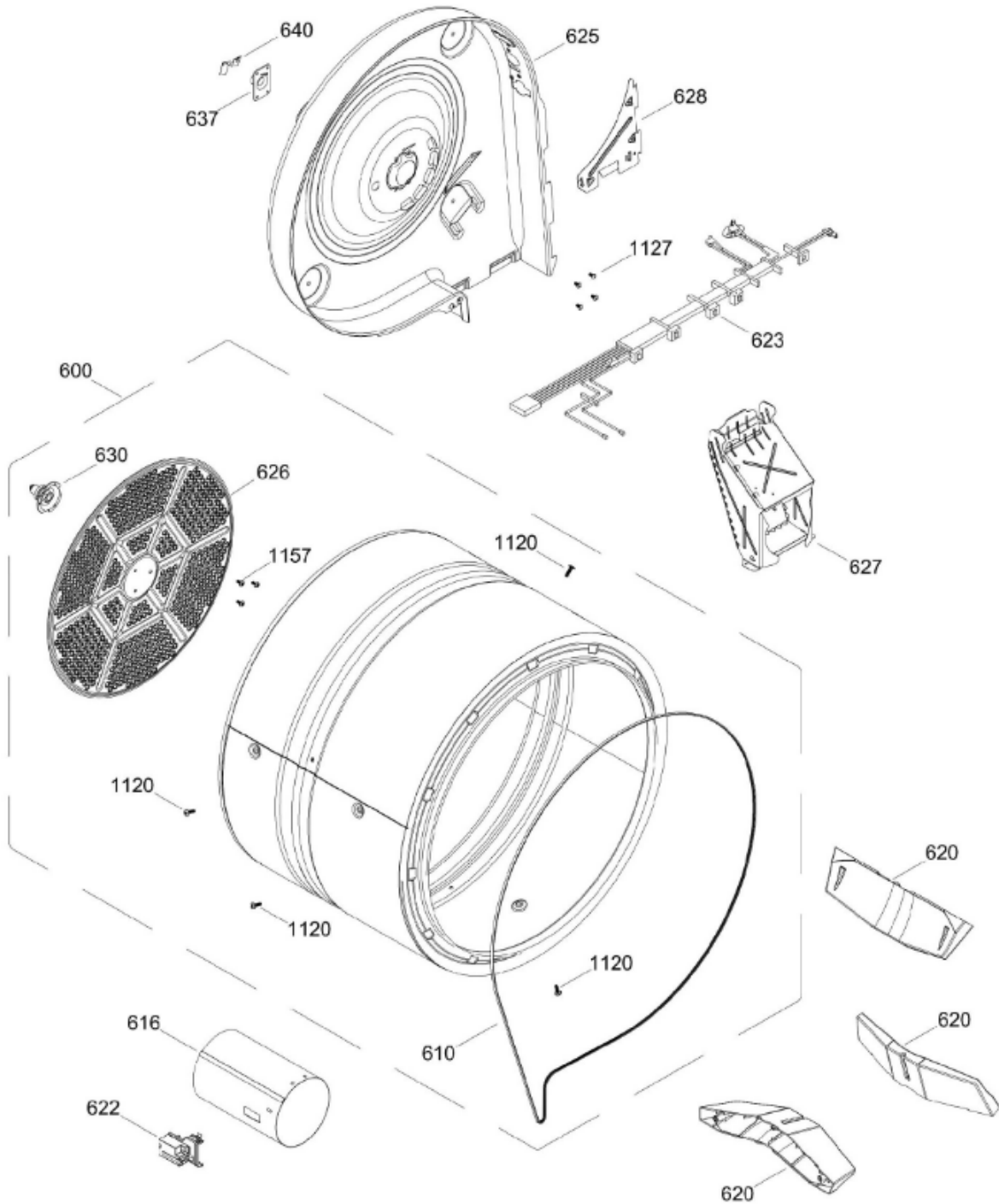

BENITO JUÁREZ #1500 GPE ZITON, CD. GUADALUPE NUEVO LEÓN TEL: 8183377999 Y 49
HORARIOS: LUNES A VIERNES 8:30 A 6:00 PM Y SÁBADOS DE 8:30 A 2:00 PM
WEB: www.denek.com



SECADORA SMW715NDGWW00

Guía	Refacción	Descripción
1	WW03L00243	PANEL DE CONTROL ENS(BCO)
1	WW02L00645	PANEL DE CONTROL ENS(BCO)
7	WW03L00344	PERILLA
31	WW03F00330	TARJETA Y CHASIS ENSAMBLE
32	WW03L00218	PROTECTOR FRONTAL
52	WW03A00153	LOGO E TECHNOLOGY
100	WW03L00219	PANEL FRONTAL BLANCO
101	WW03L00186	MARCO Y FILTRO ENS
101	WW02F00614	MARCO Y FILTRO ENS
102	WW02L00025	INTERRUPTOR PUERTA
103	WW03L00187	SELLO FILTRO
106	WW02F00613	CUBIERTA COLECTOR DE AIRE
108	WW02L00172	DOOR SWITCH COVER
109	WW02A00086	COJINETE SUP.
110	WW02L00412	TOP BEARING ENSAMBLE
110	WW02L00519	TOP BEARING ENSAMBLE
113	WW01L01329	FELPA COLECTOR DE AIRE
113	WW02F00783	FELPA COLECTOR DE AIRE
115	WW03A00015	COJINETE DESLIZABLE
116	WW03A00016	COJINETE DESLIZABLE
116	WW02A00250	COJINETE DESLIZABLE
119	WW02F00131	FIELTRO
119	WW02F00784	FIELTRO
123	WW02A00056	STRIKE PLATE
124	WW02A00057	STRIKE PLATE
125	WW02F00088	SENSOR ROD
127	WW02A00067	LAMP
127	WW03F00458	LAMP
127	WW03F00458	LAMPARA
128	WW03A00117	SELLO
129	WW03F00469	HARNAIS DE FIL
135	WW03F00307	SEGURO
136	WW03L00221	TAPON CIEGO(GRIS)
137	WW03F00308	DUCTO TRAMPA ENS
137	WW02F00610	DUCTO TRAMPA ENS

BENITO JUÁREZ #1500 GPE ZITON, CD. GUADALUPE NUEVO LEÓN TEL: 8183377999 Y 49
HORARIOS: LUNES A VIERNES 8:30 A 6:00 PM Y SÁBADOS DE 8:30 A 2:00 PM
WEB: www.denek.com



SECADORA SMW715NDGWW00

Guía	Refacción	Descripción
142	WW02A00093	NUT-STRIP DOOR GUIDE
144	WW02L00167	DOOR GUIDE
146	WW02F00135	HARNESS SENSORS
152	WW03L00190	SELLO DUCTO TRAMPA
152	WW03F00354	SELLO DUCTO TRAMPA
202	WW03L00222	PUERTA SUB ENSAMBLE
205	WW03L00223	VENTANA EXTERIOR
206	WW03F00309	MASCARA PUERTA
207	WW03A00163	ANILLO EXTERIOR PUERTA
209	WW02L00168	DOOR INNER WINDOW
213	WW02L00037	LATCH ASM.
214	WW03L00225	INSERTO JALADERA
216	WW02L00414	SELLO PUERTA
220	WW03L00227	BISAGRA ENS
236	WW02A00065	BOTON BELLEZA
240	WW03L00228	CUBIERTA BISAGRA
401	WW03L00229	CUBIERTA SUPERIOR(BCO)
403	WW03A00155	PLACA POSTERIOR
404	WW03L00205	LATERAL(BCO)
404	WW03L00205	LATERAL(BCO)
404	WW02L00644	LATERAL(BCO)
405	WW02L00191	PATTE DE NIVELLEMENT
406	WW02F00508	ENSAMBLE ARNES GAS
408	WW03L00230	BASE CHASIS
409	WW03A00080	LOGO MABE
410	WW02A00113	SUPPORT (PATTE DE NIVELLEMENT
411	WW02F00139	PATA NIVELADORA ENS
415	WW02F00261	TARJETA PRINCIPAL ENS
415	WW02F00789	TARJETA PRINCIPAL ENS
420	WW01L01170	PANEL POSTERIOR
420	WW03L00383	PANEL POSTERIOR
421	WW02F00140	MAIN POWER BOARD SUPPORT
422	WW02F00022	CORD SET RETAINER
445	WW02F00091	CABLE TOMACORRIENTE
456	WW02A00037	BRIDE

BENITO JUÁREZ #1500 GPE ZITON, CD. GUADALUPE NUEVO LEÓN TEL: 8183377999 Y 49
HORARIOS: LUNES A VIERNES 8:30 A 6:00 PM Y SÁBADOS DE 8:30 A 2:00 PM
WEB: www.denek.com



SECADORA SMW715NDGWW00

Guía	Refacción	Descripción
501	WW01F01162	VENTILADOR REDONDO
502	WW03F00311	CAJA VENTILADOR
503	WW01L01163	BASE MOTOR
503	WW01L01163	BASE MOTOR
503	WW01L01163	BASE MOTOR
503	WW02L00642	BASE MOTOR
504	WW02F00027	SOPORTE MOTOR
506	WW02F00129	DUCTO DE ESCAPE
506	WW02F00129	DUCTO DE ESCAPE
506	WW02F00721	EXHAUST DUCT
510	WW03F00447	MOTOR POLEA ENSAMBLE
514	WW02A00008	ENS. BRAZO AUXILIAR
514	WW03F00350	ENS. BRAZO AUXILIAR
520	WW02F00031	CLIP MOTOR
525	WW02A00003	TAPA
532	WW02F00003	CORREA MOTOR
532	WW02A00232	CORREA MOTOR
534	WW02A00026	EMPAQUE ESCAPE SOPLADOR
534	WW02F00785	EMPAQUE ESCAPE SOPLADOR
571	WW02A00020	QUEMADORES
572	WW02F00002	ALLUME-GAZ
572	WW02F00740	ALLUME-GAZ
573	WW03A00125	SOPORTE VALVULA DE GAS
574	WW02A00155	ENS VALVULA Y TUBERIA GAS NAT
575	WW03F00493	ENSAMBLE VALVULA Y QUEMADOR
576	WW02L00140	AIRADOR
578	WW01F01529	VALVULA Y TUBO PARA GAS LP
600	WW03F00313	TAMBOR ENSAMBLE
610	WW02F00028	BANDA SECADORA
610	WW02F00854	BANDA SECADORA
616	WW02F00260	CAMARA DE COMBUSTION
620	WW02L00143	BAFFLE
622	WW02F00001	DETECTOR TERMOSTATO
623	WW03F00477	ARNES GAS
625	WW03F00095	DIFUSOR DE GAS

BENITO JUÁREZ #1500 GPE ZITON, CD. GUADALUPE NUEVO LEÓN TEL: 8183377999 Y 49
HORARIOS: LUNES A VIERNES 8:30 A 6:00 PM Y SÁBADOS DE 8:30 A 2:00 PM
WEB: www.denek.com



SECADORA SMW715NDGWW00

Guía	Refacción	Descripción
626	WW02F00221	DIFUSOR
626	WW02F00827	DIFUSOR
627	WW02F00127	DUCTO TRANSICION
627	WW02F00127	DUCTO TRANSICION
627	WW03F00539	DUCTO TRANSICION
628	WW03F00097	PLACA DIFUSOR
630	WW02A00019	SOPORTEYFLECHAENSAMBLE
637	WW02A00005	RETENEDOR RODAMIENTO
640	WW01A00443	GROUND STRAP ASSEMBLY
640	WW02F00833	GROUND STRAP ASSEMBLY
700	WW02A00102	SCREW CHASSIS TO FRONT HSG.
704	WW02A00099	SCREW # 10
707	WW02A00097	SCREW
708	WW02A00098	SCREW
708	WW01A00539	SCREW
711	WW02A00101	TORNILLO
723	WW03A00145	TORNILLO HI/LO 8-18
728	WW02A00114	TUERCAS
729	WW03A00146	ARANDELAS
731	WW03A00147	CALZA
734	WW03A00156	TORNILLO 8-18 AB PNQ2
1101	WW02A00030	TORNILLO
1101	WW02A00211	TORNILLO
1103	WW02A00032	TORNILLO
1106	WW02A00027	SCREW
1115	WW01A00450	TORNILLO 8-18 AB 1/2
1120	WW02A00031	TORNILLO
1121	WW01A00001	TORNILLO
1127	WW01A00521	TORNILLO
1127	WW02A00211	TORNILLO
1131	WW02A00028	TORNILLO
1157	WW01A00456	TORNILLO #10