

EXPLOSIONADO DE PARTES

— ENFRIADOR DE AGUA —

MODELO | WK5915BD

Distribuidor Autorizado

SurteRápido.com

Venta de Refacciones
Electrodomesticas

ENFRIADOR WK5915BD

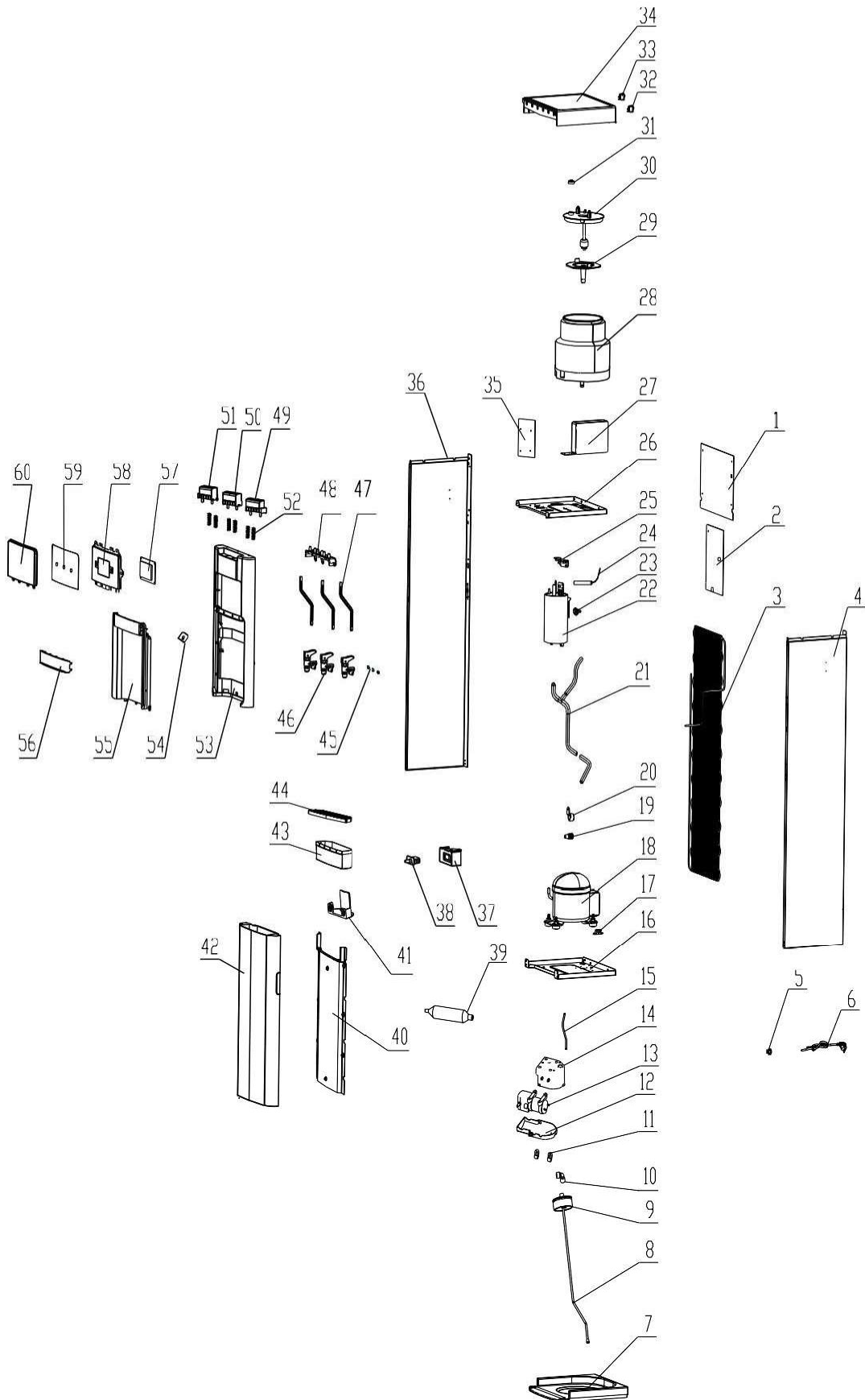

ENFRIADOR WK5915BD

Hus.	DESCRIPCIÓN	No. de Parte
1	Top Back Board	1 21015003300077
2	Under the rear cover	1 21015003400136
3	Condenser	1 21011710300150
4	Right Side Board	1 21011410100872
5	Power cord protector	1 21015002000010
6	Power Cord	1 21011261100044
7	Bottom Board	1 21015014500911
8	SST tube	1 21011412000021
9	Top of Bottle Cover <i>(Solicitar todos los numeros de parte del recuadro para este numero de parte)</i>	1 21015011600175 21015011600165 21011810100154 21011800100165
10	Speediness tie-in	3 21015000800023
11	Silica gel pad	2 21011810200053
12	Pump cover	1 21015015600020
13	Pump	1 21011210700099
14	Pump Box	1 21015015400106
15	PE pipe	1 21011900300003
16	Middle Support Plate	1 21011412400170
17	Power Cord fixer -bottom	1 21015000100010
18	Compressor (Includes Relay Start Device) <i>(Solo Relay Start)</i>	1 21011710100184 1 21011710100177
19	Drainage Subassembly <i>(Solicitar todos los numeros de parte del recuadro para este numero de parte)</i>	1 21015002200010 21015002300013
20	Drainage Cap	1 21015002300014
21	Waterway Hose Assembly	1 21011900100690
22	Hot Tank Unit	1 21011210400718
23	Manual Reset Temperature controller(95°C)	1 21011200800010
24	Electronic Temperature Control	1 21011212000025
25	Thermal Tank Support	1 21015001300069
26	Cold Tank Supporting Plate	1 21011412600083
27	Master Box	1 21011411700019
28	Cold Tank Units	1 21011910200162
29	Diffluent Cover	1 21015011800060
30	Cold Tank lid	1 21015011600140
31	Air-exchange Cap	1 21015011600141
32	Heating switch	1 21011200300050
33	Cold switch	1 21011200300051
34	Top Cover	1 21015030700036
35	PCB board	1 21011211700135

Distribuidor Autorizado



Venta de Refacciones
Electrodomesticas

ENFRIADOR WK5915BD

36	Left Side board	1	21011410200827
37	Door Switch box	1	21015015400107
38	Door Switch	1	21011200400010
39	Drier filter	1	21011700200022
40	Door lining	1	21015016600246
41	Link up with	1	21015001300093
42	Door	1	21015030800048
43	Water collecting box	1	21015010500961
44	Water collecting box net	1	21015010601000
45	Card spring	3	21011413000129
46	Faucet unit	3	21015013600025
47	Connecting Rod	3	21015018400013
48	Faucet holder	1	21015001300079
49	Cold Water button	1	21015030400023
50	Normal Water button	1	21015030400024
51	Hot Water button	1	21015030400022
52	Spring	6	21011413000107
53	Front shell	1	21015061001275
54	Night LED light	1	21011212500579
55	Front Shell edge	1	21015012500241
56	SST panel board	1	21011411100076
57	Display screen	1	21011212800249
58	Screen fixed plate	1	21015012500198
59	Face Stickers	1	21011511000503
60	Display Window	1	21015012700189
**	Float Switch	1	21011212200027
61	Electronic Temperature Control	1	21011212000026