

## EXPLOSIONADO DE PARTES



## REFRIGERADORES NACIONALES TOP MOUNT

MODELO:

WT3050D01

# REFRIGERADOR WT3050D01

Marca	Whirlpool
Capacidad	13 pies
Color	Silver

## Parrillas / Cajones

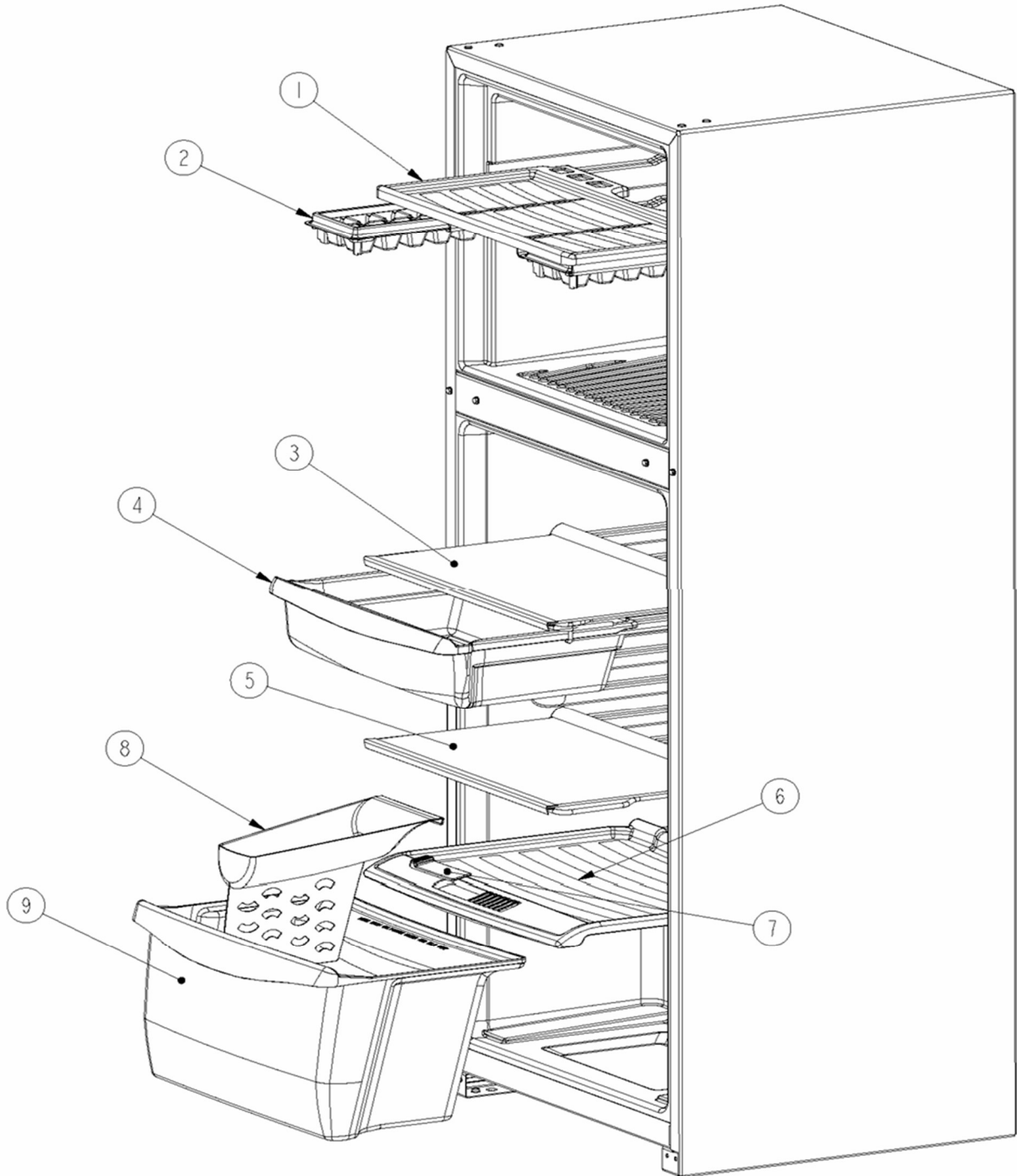

# REFRIGERADOR WT3050D01

<b>Marca</b>		<b>Whirlpool</b>	
<b>Capacidad</b>		<b>13 pies</b>	
<b>Color</b>		<b>Silver</b>	
<b>Parrillas / Cajones</b>			
<b>R e f</b>	<b>Descripción</b>	<b>C a n t</b>	<b>Numero de Parte</b>
1	Parrilla para charola de cubos de hielo (SHELF F.C.PLASTIC CLEAR)	1	2211163
2	Charola para cubos de hielo (ICE TRAY)	**	W10191336
3	Parrilla de Plastico (SHELF FRAME)	1	W10191332
4	Cajón de carnes (cajón multiusos) (MEAT PAN-WHIRLPOOL)	**	2219070
5	Parrilla completa de cristal (SHELF ASSY GLASS RC WHLP)	2	W10191331
6	Cubierta cajón legumbrero plastico (CRISPER & GLASS SUB-ASSY)	1	2222268
7	Control de humedad cajón legumbrero (HUMIDITY CONTROL WHIRLP)	1	2211185
8	Divisor cajón legumbrero (DIVIDER CRISPER PAN WHLP)	**	***
9	Cajón legumbrero (PAN CRISPER WHIRLPOOL)	1	W10166225

# REFRIGERADOR WT3050D01

Marca	Whirlpool
Capacidad	13 pies
Color	Silver

## Sistema de aire / Caja control

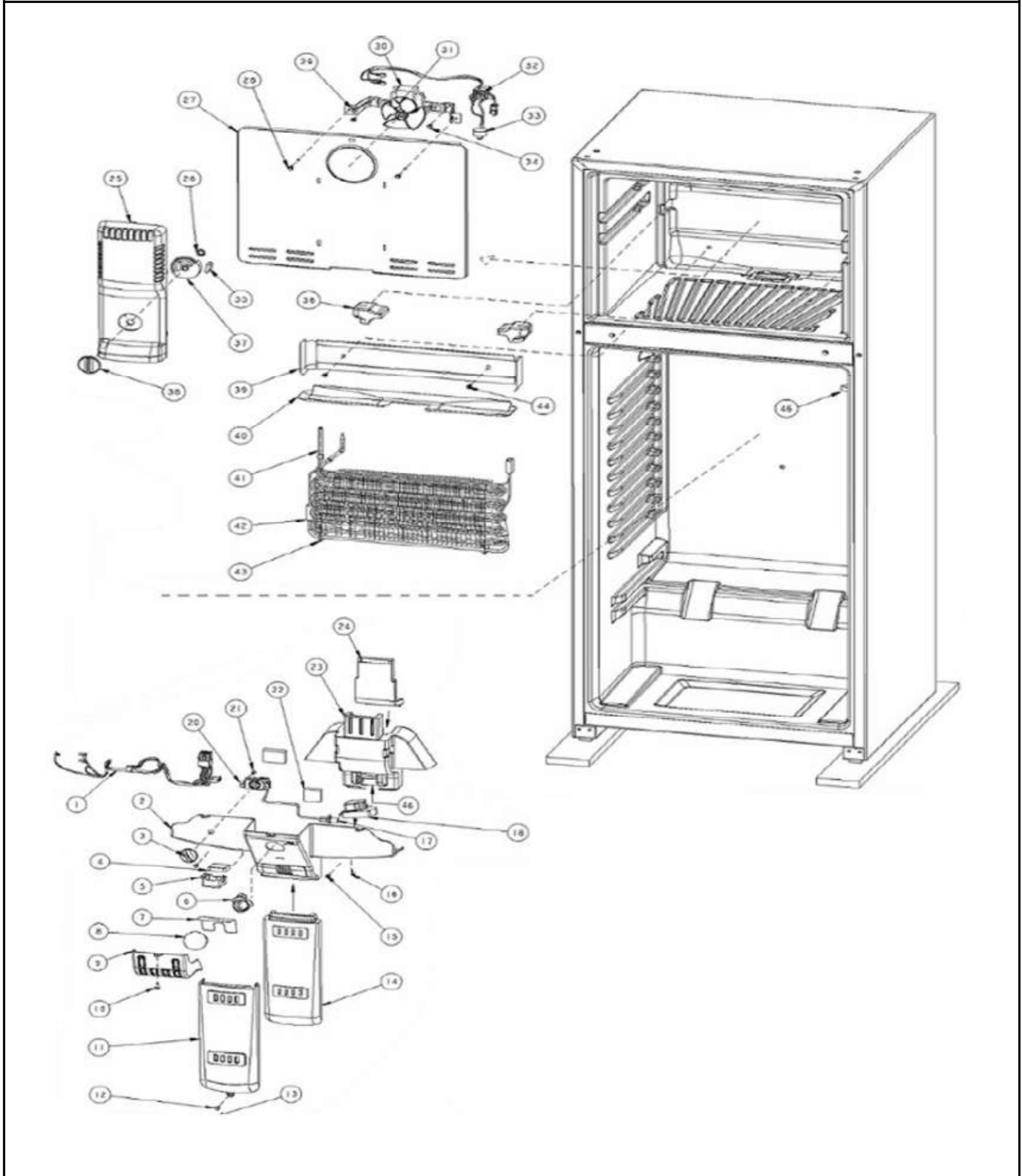

## REFRIGERADOR WT3050D01

Marca		Whirlpool	
Capacidad		13 pies	
Color		Silver	
Sistema de aire / Caja control			
R e f	Descripción	C a n t	Numero de Parte
1	Arnes para caja de control (WIRE ASSY-CONTROL BOX)	1	W10231877
2	Caja de controles (CONTROL BOX SUBASSY WHIRLPOOL)	1	W10191306
3	Perilla termostato (KNOB-THERMOSTAT)	1	2211234
4	Deodorizador	*	***
5	Soporte deodorizador	*	***
6	Socket	*	2263413
7	Protector foco	*	***
8	Foco	1	W10194651
9	Cubierta foco (COVER LIGHT RC)	1	W10134373
10	Tornillo 8-18x0.500 (8-18 X .500 UCHF AB)	**	***
11	Cubierta del cuerpo del difusor de aire (KIT COVER AIR DIFFUSER)	1	***
12	Tornillo 8-18x0.500 (8-18 X .500 UCHF AB)	**	***
13	Tapon central de gabinete (PLUG-HOLE)	1	2211250D
14	Extensión cuerpo del difusor de aire (BODY AIR DIFF. CTRL. BOX)	1	W10191323
15	Tornillo 8-18x0.500 (8-18 X .500 UCHF AB)	**	***
16	Tornillo 6-20x0.500 (6-20 X .500 Ñ8TR CR BT)	**	***
17	Funda para termostato	1	2200831
18	Timer de deshielo (DEFROST TIMER-PARAGON)	1	2188372
20	Termostato (THERMOSTAT & WEIGHT ASSY)	1	W10191321
21	Tornillo 6-20x0.500 #8tr (6-20 X .500 Ñ8TR CR BT)	**	***
23	Cuerpo del difusor de aire frontal (BODY-AIR DIFFUSER,FRONT)	1	W10134374
24	Cuerpo del difusor de aire posterior (BODY-AIR DIFFUSER,REAR)	1	W10238902
25	Torre de aire Whirlpool (TOWER-AIR)	1	W10191318
26	Tuerca de presión del damper (NUT-PUSH,DAMPER)	1	2211239
27	Cubierta evaporador (COVER EVAPORATOR)	1	W10134368
28	Tornillo 8-18x0.500 (8-18 X .500 UCHF AB)	**	***
30	Motor abanico (FAN MOTOR & BRKT ASSY)	1	W10181967
31	Aspas para motor abanico (BLADE-FAN,EVAPORATOR)	1	2169142
32	Arnés para congelador (WIRE ASSY-FRZR.COMPT.-U.L)	1	W10164677
34	Tornillo 8-18x0.600 (8-18 X .600 MHW 30DEG LSE)	**	***
36	Lateral de hielo seco para evap. (WEDGE-EVAP,MTG)	2	2210813
37	Damper del congelador (DAMPER-FRZ CONTROL)	1	2211238
38	Perilla de control congelador (KNOB-FRZ CONTROL)	1	2211237
39	Charola de deshielo (SHIELD-HEAT)	1	W10134367
40	Ducto caja para drenado (PAN-DRAIN ZINTROALUM)	1	2265095
41	Evaporador ensamble (EVAPORATOR ASSY)	1	2211094
42	Resistencia de deshielo (HEATER-DEFROST)	1	2210895
43	Soporte resistencia de deshielo (BRACKET-HEATER DEFROST)	2	2211075
44	Tornillo 8-18x0.600 (8-18 X .600 MHW 30DEG LSE)	**	***
45	Switch del foco	*	***
46	Cucharón de desagüe (DRAIN-CUP)	1	2211236
✓	Adaptador protector socket (Shroud light)	*	***

# REFRIGERADOR WT3050D01

Marca	Whirlpool
Capacidad	13 pies
Color	Silver

## Puertas / Contrapuertas

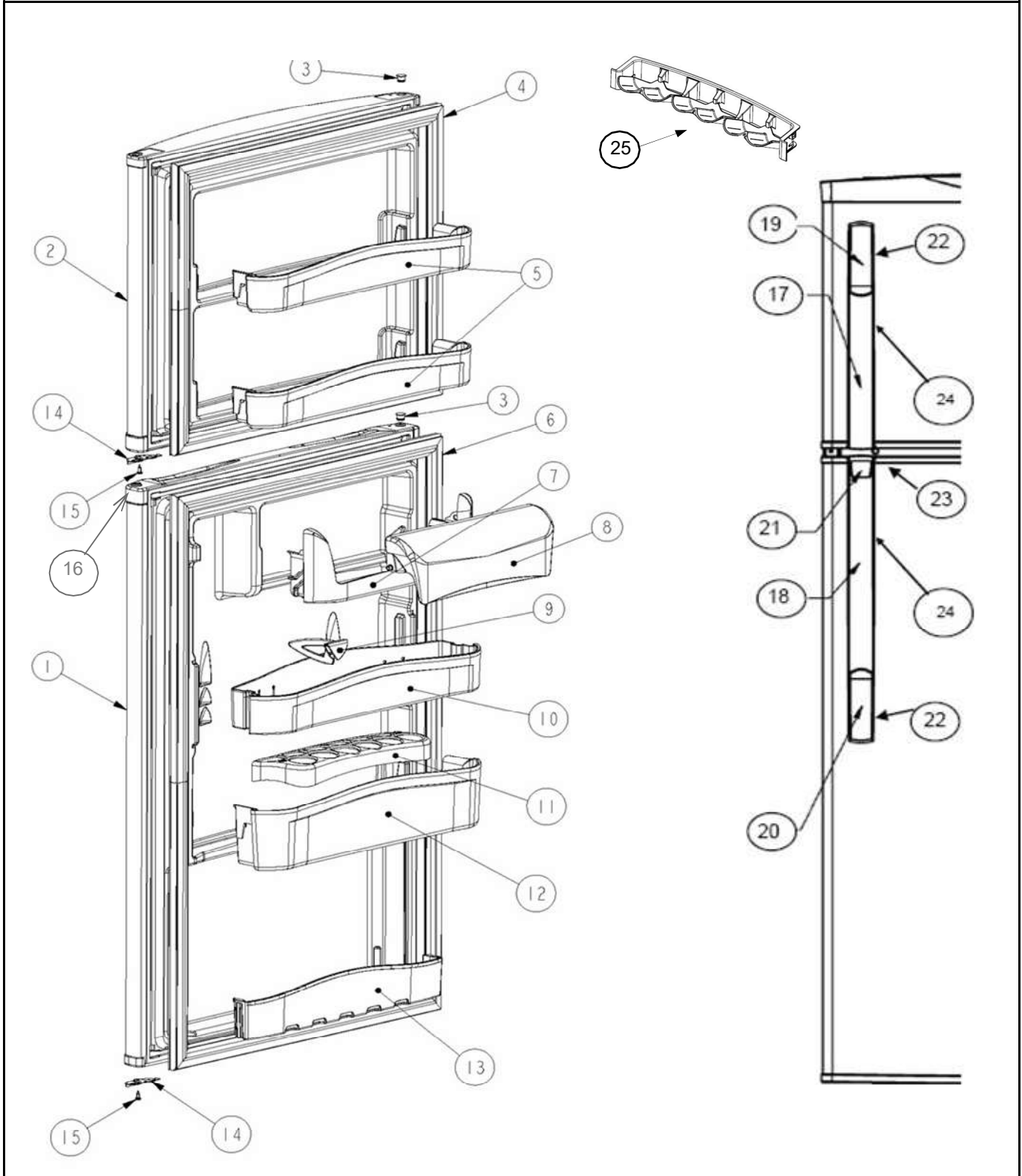

## REFRIGERADOR WT3050D01

Marca		Whirlpool	
Capacidad		13 pies	
Color		Silver	
Puertas			
R e f	Descripción	C a n t	Numero de Parte
1	Puerta ensamble refrigerador (DOOR ASSY,RC 13'WHPL NON)	1	W10197231
2	Puerta ensamble congelador (DOOR ASSY,FC 13'WHIRLPOOL)	1	W10197232
3	Tapón para agujero de bisagra (Puertas) (THIMBLE-DOOR)	2	2210973
4	Empaque magnético congelador (GASKET-DOOR, FC 13'TFA)	1	W10134341
5	Anaquele congelador (TRIVET FC WHIRLPOOL)	2	W10172990
6	Empaque magnético refrigerador (GASKET-DOOR, RC 13'TFA)	1	W10134345
7	Puerta multiusos superior (mantequillera)	*	***
8	Cubierta multiusos superior (mantequillera)	*	***
9	Divisor de barandilla (separador de botellas) (RETAINER BOTTLE)	**	***
10	Anaquele refrigerador superior (ADJUSTABLE BIN RC WHPL)	2	W10173000
11	Charola para huevos (EGG RACK)	**	***
12	Anaquele refrigerador media (TRIVET TALL BOTTLE RC WHP)	1	W10172992
13	Anaquele refrigerador inferior (TRIVET BOTTOM, RC WHP)	**	W10172991
14	Freno puerta (BRACKET DOOR STOP)	1	2211124
15	Tornillo 8-15x0.500 PN CR A	**	***
16	Capsula de giro superior/inferior	4	983604
17	Jaladera congelador (HANDLE FC,GAS AID BISCUIT)	1	W10317814
18	Jaladera refrigerador (HANDLE RC,GAS AID BISCUIT)	1	W10317815
19	Remate jaladera congelador (INSERT CAP HANDLE)	1	W10171727
20	Remate jaladera refrigerador (INSERT CAP HANDLE)	1	W10171727
21	Placa marca jaladera	*	***
22	Tornillo remates (8-18 X .625 TR CR AB LSER)	**	***
23	Tornillo end cap	*	***
24	Cubierta Jaladeras (COVER HANDLE)	1	W10317321
25	Rack para Latas (CAN RACK ASSY)	**	***

# REFRIGERADOR WT3050D01

Marca	Whirlpool
Capacidad	13 pies
Color	Silver

## Gabinete

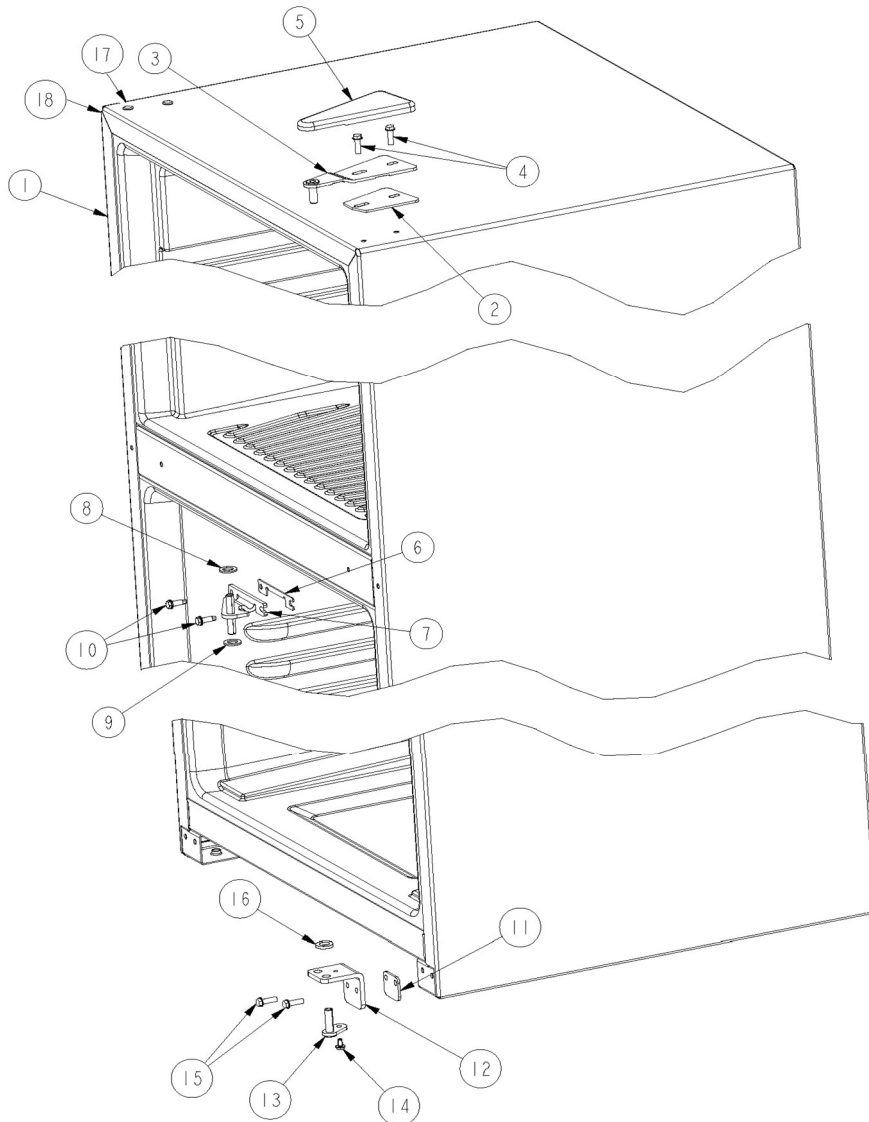



# REFRIGERADOR WT3050D01

Marca		Whirlpool	
Capacidad		13 pies	
Color		Silver	
Gabinete			
R e f	Descripción	C a n t	Numero de Parte
1	Gabinete (CABINET ASSY,13'STD)	*	***
2	Separador de bisagra superior (SHIM-HINGE BUTT)	1	W10225156
3	Bisagra superior (HINGE ASSY-TOP)	1	W10251116
4	Tornillo 12-24x0.685 AHW	**	***
5	Cubierta para bisagra (HINGE COVER)	**	W10224657
6	Separador bisagra central (SHIM-HINGE BUTT-CENTER)	1	2166043
7	Bisagra central (HINGE ASSY-CENTER)	1	2211114
8	Arandela de nylon inferior (.419ID .719OD .062TK FLW)	**	***
9	Arandela de nylon inferior (.419ID .719OD .062TK FLW)	**	***
10	Tronillo 12-24 para bisagra central	**	***
11	Separador bisagra inferior (SHIM - HINGE BOTTOM)	1	2211299
13	Bisagra inferior (HINGE ASSY-BOTTOM(RIGHT))	1	2211161
14	Tornillo 10-32x0.313 HW (10-32 X .313 HW)	**	***
15	Tornillo 12-24x0.685 AHW (12-24 X .700 AHW RLR)	**	***
16	Arandela de nylon 7/16 (.419ID .719OD .109TK FLW)	1	***
17	Tapón para agujero de bisagra (HOLE PLUG-PRESS FIT)	4	2326060
18	Vista para esquina gabinete (CORNER FILLER CAB)	2	2326063

# REFRIGERADOR WT3050D01

Marca	Whirlpool
Capacidad	13 pies
Color	Silver

**Sistema Sellado**

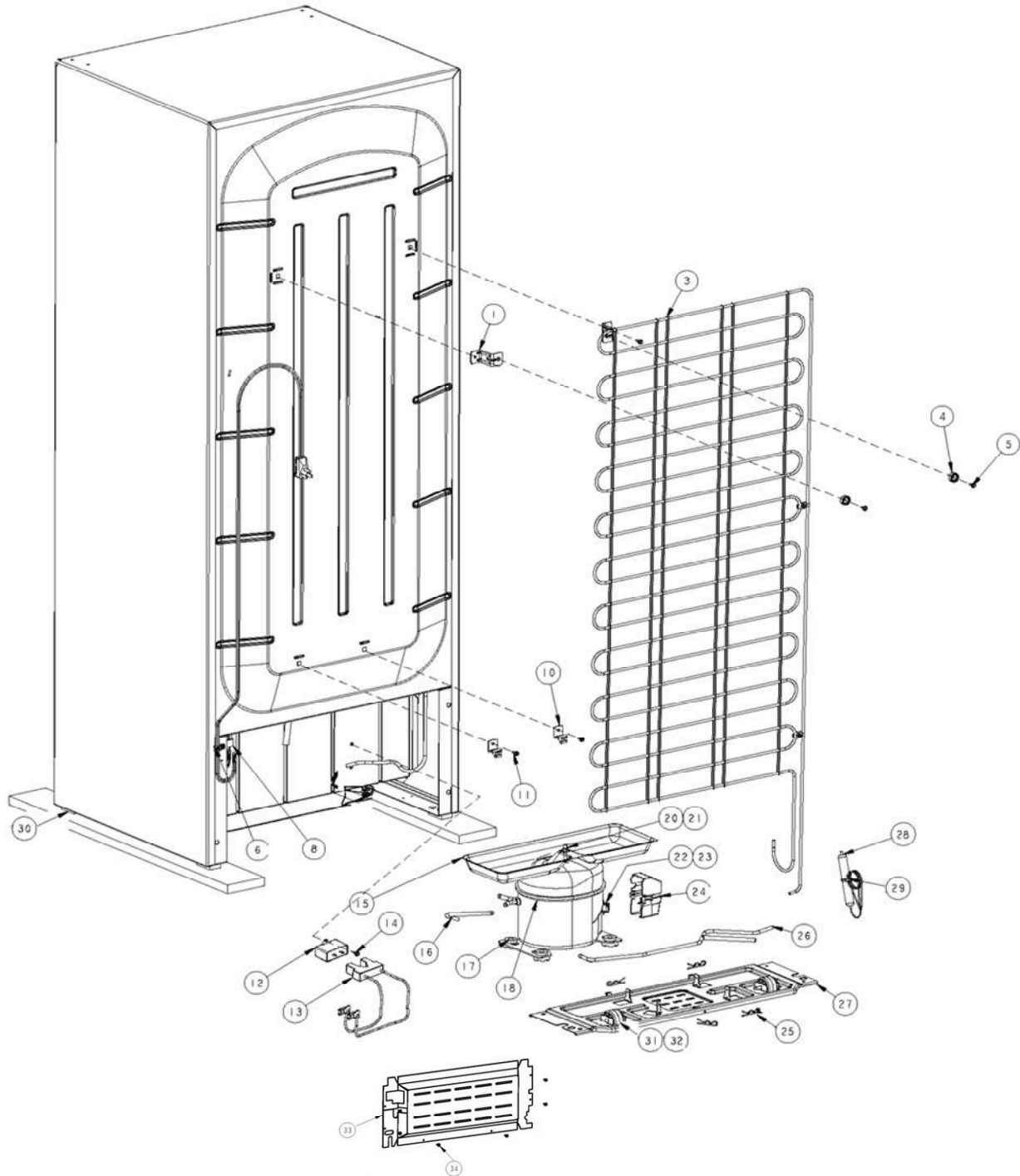

## REFRIGERADOR WT3050D01

Marca		Whirlpool	
Capacidad		13 pies	
Color		Silver	
Sistema Sellado			
R e f	Descripción	C a n t	Numero de Parte
1	Bracket para condensador (PLASTIC SPACER-CONDENSER)	2	2258451
3	Condensador (CONDENSER ASSY-FORMED 13)	1	W10219450
4	Arandela plana 1/4 ZN	2	VS611
5	Tornillo 8-18 X 3.000 HW	**	***
6	Arnés principal (WIRE ASSY UNIT)	1	W10209286
8	Tornillo 8-18x0.600	**	***
***	Tornillo para tierra	*	***
10	Clip condensador (CLIP-CONDENSER)	2	2172892
11	Tornillo 8-18x0.600	**	***
12	Capacitor (CAPACITOR-RUN,MAT)	1	2264017
13	Arnés para capacitor	*	***
14	Tornillo8-18x0.600	**	***
15	Charola de evaporación (EVAP. TRAY)	1	2321188
16	Tubo de proceso (PROCESS TUBE)	1	VS20001
17	Amortiguador GROMMET-COMPRESSOR	4	2264447
18	Compresor (CPRSR-EMB-EMY60)	1	W10294440
20	Espaciador para charola de evaporación (STRIP SPACER)	1	2264589
21	Tuerca de presión de charola de evaporación (HEX WASH BASE LOCK	1	489153
22	Relevador	*	***
23	Protector térmico	*	***
24	Combo device (incluye 22 y 23) (5SP START/PROTECT COMB.DEVICE	1	W10330836
25	Chavetas (COTTER PIN)	4	24364001
26	Tubo de descarga (PRECOOLER ASSY-SLEEVE 13')	1	W10294438
27	Soporte compresor (COMPRESSOR SUPPORT PLATE)	1	W10222447
28	Filtro deshidratador (DRIER ASSEMBLY)	1	W10190413
29	Cintillo (STRAP)	1	2263990
30	Tornillo nivelador (CTL NO-LEVELER)	2	999203
31	Rodillo trasero (ROLLER)	2	2150304
32	Perno para rodillo (RIVET-AXLE)	2	2264756
33	Tapa trasera (cover unit)	*	***
34	Tornillo tapa trasera	*	***

Nota: La referencia que aparezcan en su num de parte con asteriscos \*\*\*

Indica que no aplica para este modelo.