

# Whirlpool

## WWI16ASHLA MANUAL DE PARTES PARTS MANUAL

Lavado

Laundry



- Cap: 16kg
- Orig: Colombia
- Color: Blanco/ Grey

# LAVADORA WWI16ASHLA

## Cubierta

## Top & Dispenser

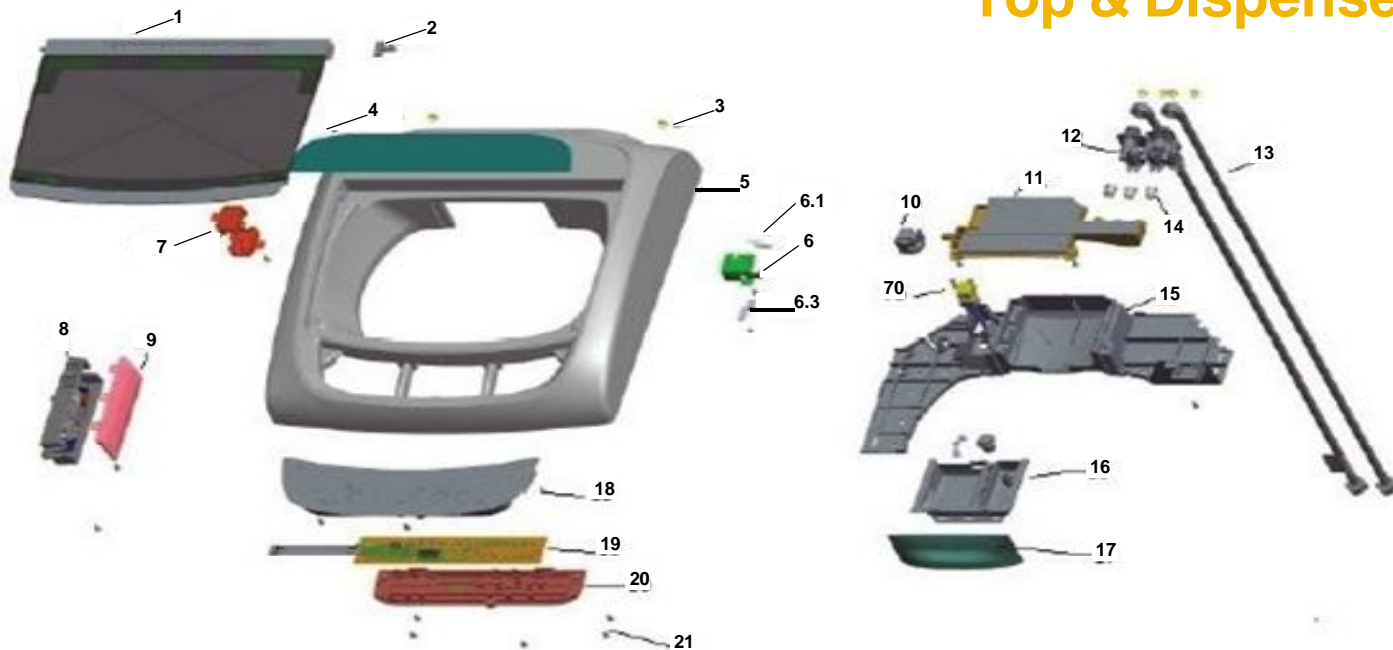

Ref.	Part Number	Descripción	Qty
1	W10637005	Conjunto tapa móvil	1
2	W10679136	Perno bisagra	1
2.1	W10406876	Buje perno bisagra	1
2.2	W10472321	Clip bisagra	2
3	326016639	Tornillo abau auto-atar c/fen s/fla 3,5x13	4
4	W10693699	Panel decorativo trazero	1
5	W10677778	Cubierta	1
6	W10691654	Interruptor	1
6.1	W10655121	Soporte interruptor	1
6.2	W10260856	Tornillo	1
6.3	W10655120	Haste interruptor	1
7	W10699981	Protector conector conjunto de cables	1
7.1	326003857	Tornillo lobular	1
8	W10804226	Controle electrónico de potencia	1
9	W10661829	Tapa controle elec trónico de potencia	1
9.1	326016639	Tornillo abau auto-atar c/fen s/fla 3,5x13	5
10	W10416686	Presostato linear	1
10.1	W10746061	Manguera presostato	1
10.2	394230	Abrazadera	1
11	W10732520	Soporte dispenser	1
12	W10718177	Válvula doble 127v 60hz	1

Ref.	Part Number	Descripción	Qty
12.1	W10718167	Válvula simples	1
12.2	W10750809	Tapon válvula de entrada de agua	1
13	W10719350	Manguera de entrada de agua caliente	1
13	W10757962	Manguera de entrada de agua fría	1
14	W10732780	Guarnición	2
15	W10763019	Protector	1
17	W10677785	Dispenser: cajon (ref 16) + tirador (ref 17)	1
18	W10703096	Panel decorativo	1
18.1	W10637000	Soporte consola plástico	1
18.2	W10820994	Soporte consola plást + panel decorativo	1
19	W10704106	Conjunto interface + cables	1
19.1	W10677795	Conjunto de cables (superior)	1
20	W10661384	Tapa interface	1
20.1	W10677794	Conjunto de cables (inferior)	1
21	326016639	Tornillo abau auto-atar c/fen s/fla 3,5x13	4

# LAVADORA WWI16ASHLA

## Motor, transmisión y tina

## Motor, transmission and tub



Ref.	Part Number	Descripción	Qty	Ref.	Part Number	Descripción	Qty
22	W10716069	Anillo tina	1	48	W10470951	Correa poli v	1
23	W10820981	Impeller + tornillo	1	49	W10682688	Soporte del motor	1
23.1	W10769818	Tapa impeller	1	49.1	28290	Tornillo sext metr s/fen c/fla m8x16	4
23.2	W10356737	Tornillo	4	49.2	4260171	Tornillo sext metr s/fen c/fla 4,8x13	3
24	W10694416	Mini impeller	3	49.3	390160	Tornillo fran metr s/fen s/fla 8x20	2
26	W10738106	Torre recirculación sin filtro	1	49.4	390380	Tuerca (50019864)	2
26.1	W10760339	Guarnición torre sin filtro	2	50	W10731945	Conjunto electrobomba 127v 60hz	1
27	W10719070	Drive block	1	50.1	W10342571	Anillo vedación	1
29	W10770058	Conjunto filtro(incluye 30 y 31)	1	50.2	W10342570	Tornillo	3
32	W10673302	Torre recirculación con filtro	1	50.3	326016091	Tornillo	6
32.1	W10760335	Guarnición torre con filtro	2	51	W10527850	Capacitor 250v 127v 60hz	1
32.2	W10772018	Tornillo torre recirculación	4	52	W10777926	Abrazadera capacitor	1
32.3	W10772017	Tornillo torre recirculación	4	52.1	4260171	Tornillo sext metr s/fen c/fla 4,8x13	1
33	W10644230	Conjunto cesta	1	53	390510	Anillo retención	1
35	W10761020	Conjunto tina	1	54	W10734499	Came articulado	1
35.1	W10590065	Tornillo sext hi-lo s/fen c/fla 3,9x18	2	55	W10710251	Anillo deslizante	1
35.2	W10705286	Filtro drenaje (tina)	1	56	W10718075	Came externo	1
37	W10647949	Anillo	1	57	360570	Resorte del came	1
40	326034407	Sello	1	58	W10750005	Polea poli v	1
41	W10762611	Conjunto soporte drive system	1	58.1	W10548856	Tuerca	1
42	W10762478	Conjunto apoyo banda freno	1	59	W10734540	Conjunto protector polea	1
44	W10682573	Conjunto freno	1	59.1	4260171	Tornillo sext métrico sin fen con fla 4,8x13	2
44.1	326001560	Resorte del freno	1	60	W10701107	Conjunto suspensión	1
45	W10518616	Actuador del freno 127v 60hz	1	61	W10755959	Guia del amortiguador	1
45.1	W10575321	Tornillo sext hi-lo s/fen c/fla 4,8x11	2	62	W10710885	Amortiguador	1
47	W10488059	Motor welling 127v 60hz	1	63	W10728920	Apoyo suspensión	1

Distribuidor Autorizado

**SurteRápido.com**

Venta de Refacciones  
Electrodomesticas

# LAVADORA WWI16ASHLA

Gabinete

Cabinet

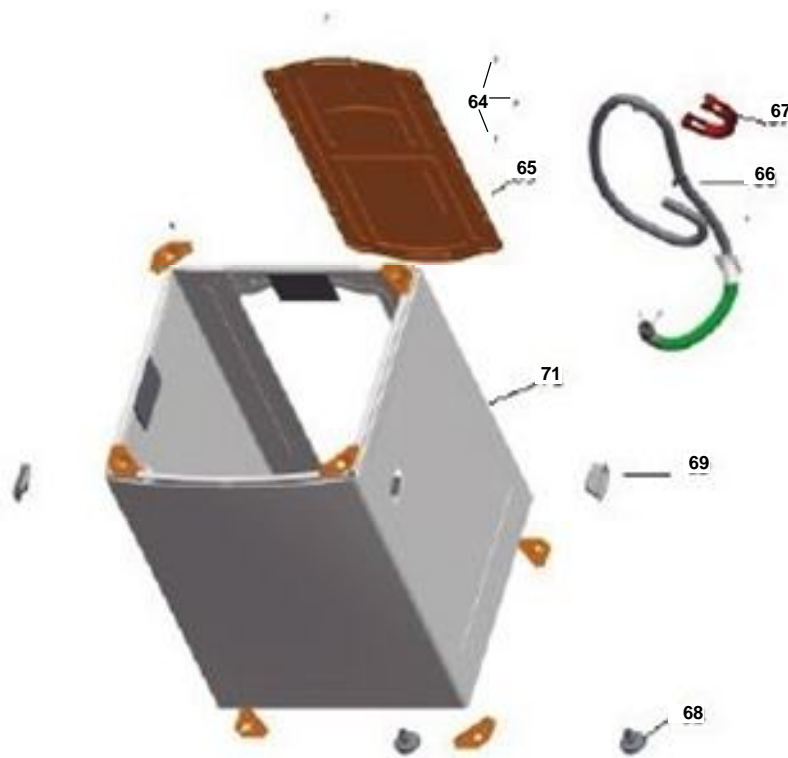

Ref.	Part Number	Descripción	Qty	Ref.	Part Number	Descripción	Qty
64	326049975	Tomillo tapa de inspección	12	70	W10735792	Interruptor de desbalanceo	1
65	W10638599	Tapa de inspección	1	70.1	W10539667	Tomillo sext m5x11 flange lisa zincado	3
66	W10797446	Manguera drenaje	1	70.2	326016639	Tomillo abau auto-atar c/fen s/fla 3,5x13	5
66.1	W10732425	Abrazadera electrobomba vortex	1	70.3	W10539667	Tomillo sext m5x11 flange lisa zincado	4
66.2	20046	Remache 4,8 x 9,0 mm	1	71	W10816374	Gabinete com patas y manguera drenaje	1
68	W10681374	Pata niveladora color negro	4	71.1	W10713714	Pad gabinete	3
69	W10638601	Alza	2	999	390640	Tomillo sext metr s/fen c/fla 10/32x3/8	1
				999	394230	Abrazadera	1
				999	W10717791	Embalaje base	1
				999	W10717794	Embalaje calzo cesta	1
				999	W10717792	Embalaje cantonera frontal	1
				999	W10717793	Embalaje cantonera trazera	1
				999	W10672816	Embalaje tapa	1